

INSTRUCTION MANUAL

FOR...

**TRANSCEIVER
MODEL TR-9**

INSTRUCTION MANUAL
FOR
TRANSCEIVER
MODEL TR-9

Manufactured by:
The Hallicrafters Co.
600 Hicks Road
Rolling Meadows, Illinois 60008

the hallicrafters co.



A Subsidiary of Northrop Corporation

Printed in U.S.A.
869

094-904777
Issue A

TABLE OF CONTENTS

Section		Page
I	INTRODUCTION	1
	1-1 Purpose of Equipment	1
	1-2 Functional Description	1
	1-3 Physical Description	1
II	SPECIFICATIONS	1
	2-1 Transmitter and Receiver Specifications	1
III	INSTALLATION AND ADJUSTMENT	3
	3-1 Unpacking	3
	3-2 Preliminary Procedures	3
	3-3 Antenna	3
	3-4 Functions of Operating Controls	3
IV	OPERATION	6
	4-1 General	6
	4-2 Transceiver Operation	6
	4-3 Microphone Operation (Master Oscillator)	7
	4-4 Microphone Operation (Crystal Control)	7
	4-5 CW Operation (Master Oscillator)	8
	4-6 CW Operation (Crystal Control)	8
	4-7 Antenna Tuner	8
	4-8 Doublet Antenna	8
	4-9 Fifteen-Foot Whip Antenna	10
	4-10 Long Wire Antenna	10
	4-11 Random Lengths of Wire	10
	4-12 Fifty-Foot Sloping Antenna	11
	4-13 Packset Antenna	11
	4-14 Operating the Packset Antenna	13
V	THEORY OF OPERATION	13
	5-1 Introduction	13
	5-2 Theory of Operation (Receiver)	13
	5-3 Theory of Operation (Transmitter)	17
	5-4 Theory of Operation (Modulator)	18
VI	CALIBRATION AND ALIGNMENT PROCEDURES	18
	6-1 General	18
	6-2 Test Equipment	18
	6-3 Removal of Chassis	18
	6-4 IF Amplifier and BFO Alignment	18
	6-5 Calibration and Alignment (Receiver)	18
	6-6 AGC Voltage Adjustment	22
	6-7 Signal Strength Meter Adjustment	22
	6-8 Calibration and Alignment (Transmitter)	22
	6-9 Antenna Bridge Adjustment	24
	6-10 Modulation Adjustment	24

LIST OF ILLUSTRATIONS

Figure		Page
1-1	TR-9 Transceiver	vi
3-1	Operating Controls	4
4-1	Typical Antenna Installation	9
4-2	Fifteen-Foot Whip Antenna Installation	10
4-3	Fifty-Foot Sloping Antenna Installation	12
5-1	Overall Block Diagram	14
5-2	Schematic Diagram (Sheet 1 of 2)	15
5-2	Schematic Diagram (Sheet 2 of 2)	16
6-1	Adjustment Locations (Top View)	19
6-2	Adjustment Locations (Bottom View)	20
6-3	Adjustment Locations (Right Side View)	21
6-4	Modulation Waveforms	25

LIST OF TABLES

Table		Page
2-1	Performance Specifications	1
3-1	Operating Control Functions	4
4-1	Approximate Lengths for Given Frequencies on Typical Antenna Installation	9
4-2	Counter Dial Settings for Use With Fifteen-Foot Whip Antenna	11
4-3	Long Wire Antenna Length Including Lead-in	11
4-4	Antenna Tuner Settings for Fifty-Foot Sloping Antenna Operation	12
4-5	Antenna Tuner Settings for Packset Antenna Operation	13
6-1	Receiver Alignment and Calibration Frequencies and Alignment Components	23
6-2	Transmitter Alignment and Calibration Frequencies and Alignment Components	23

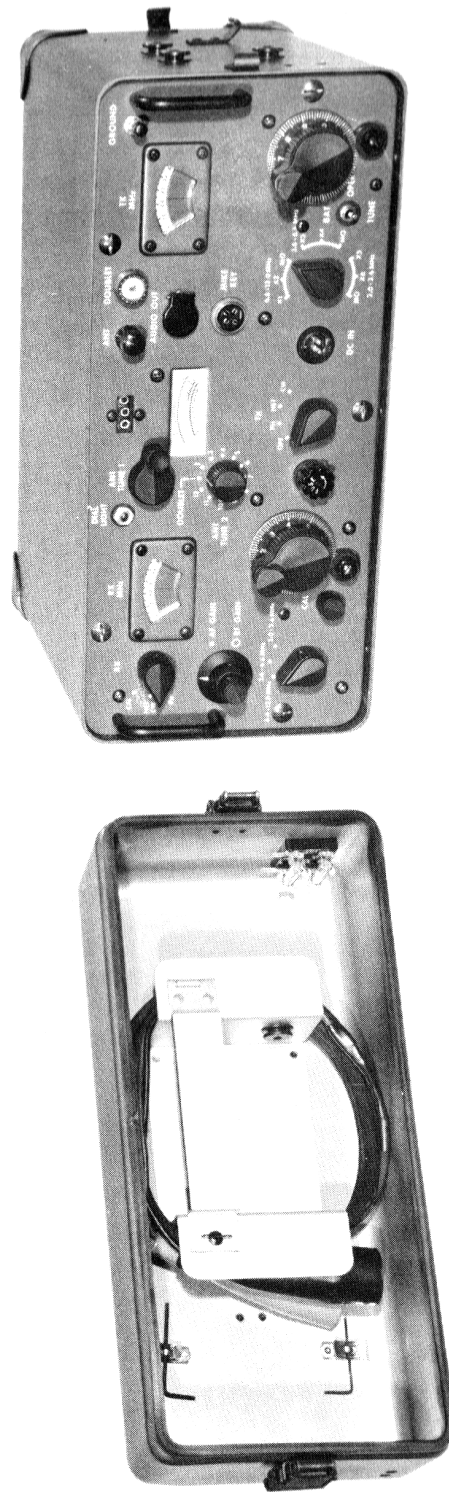

156-014465

Figure 1-1. TR-9 Transceiver.

SECTION I INTRODUCTION

1-1. PURPOSE OF EQUIPMENT. The Hallcrafters Model TR-9 Transceiver (figure 1-1) is a rugged, lightweight, fully transistorized, amplitude modulated or CW transceiver designed to operate in the 2- to 12-MHz frequency range. The transceiver is designed to provide reliable communications under adverse conditions in either portable, mobile, or base-station operation. A complete line of accessories is also available to expand the transceiver capabilities. See Section VIII for listing of the optional accessories.

1-2. FUNCTIONAL DESCRIPTION. The frequency coverage of the transceiver is provided by utilizing three separate bands: 2.0 to 3.6 MHz, 3.6 to 6.6 MHz, and 6.6 to 12 MHz. The transmitter section provides continuously variable coverage over the entire frequency range, utilizing a variable frequency oscillator as the frequency determining device. In addition, six crystal-controlled frequencies are available, two frequencies per band. The receiver section, utilizing three separate bands, also provides continuously variable coverage over the entire frequency range. The receiver is a separate section and is independent of the transmitter.

Therefore, the receiver can be operated on frequencies different from those used by the transmitter, within the frequency range of the employed antenna. The transceiver has provisions for netting the transmitter to the receiver for single frequency operation. All circuits have been carefully designed to obtain the maximum performance and efficiency from the transceiver. The receiver and transmitter oscillators employ field effect transistors to obtain maximum frequency stability while the modulator circuits operate in a Class B mode to obtain minimum battery drain. The transmitter final amplifier utilizes two transistors in a push-pull configuration to reduce the number of harmonic products and to simplify the tuned circuit design. The transceiver operates from a 12-volt DC source (storage battery). Optional power sources are also available for AC operation and field operation. See Section VIII for optional power sources.

1-3. PHYSICAL DESCRIPTION. The overall dimensions of the transceiver, including the removable moisture proof cover, is 6 inches high by 12-1/2 inches wide by 15 inches deep. Weight of the unit is approximately 18-1/2 pounds.

SECTION II SPECIFICATIONS

2-1. TRANSMITTER AND RECEIVER SPECIFICATIONS. Table 2-1 lists the performance specifications.

for the transmitter and receiver sections in the Model TR-9 Transceiver.

Table 2-1. Performance Specifications.

GENERAL	
Input Power:	12.6 volts DC, 3 amperes (average) in transmit mode 12.6 volts DC, 0.09 ampere (no signal) in receive mode
Usable Input Voltage:	10 to 15 volts DC
Transmit Cycle:	Continuous
Temperature Range:	-10 °C to +50 °C within specifications -20 °C to +65 °C operational
Altitude:	Sea level to 10,000 feet
Humidity:	To 95% relative humidity

Table 2-1. Performance Specifications (CONT).

TRANSMITTER	
Power Output:	AM, 10 watts nominal CW, 10 watts nominal
Emission:	Mode of operation; AM, push-to-talk CW, accessory CW key plugged into front panel
Frequency Range:	Low band - 2 to 3.6 MHz Middle band - 3.6 to 6.6 MHz High band - 6.6 to 12 MHz
Frequency Control:	Variable frequency oscillator or crystal controlled Method selected by panel switch
Spurious Attenuation:	Greater than -30 DB
Hum and Noise Level:	Better than -50 DB below rated output
Audio Clipping:	No more than 3 DB change in output for a +10 DB increase in input referenced to a 0.03-volt input signal
Audio Bandwidth:	Not more than 3 DB attenuation between 525 to 3,000 Hz. At 6,000 Hz better than -30 DB over that obtainable at 3,000 Hz.
Audio Distortion:	Not more than 10%
Modulation Percentage:	80%, average
RECEIVER	
Circuit:	Superheterodyne
Frequency Range:	Low band - 2 to 3.6 MHz Middle band - 3.6 to 6.6 MHz High band - 6.6 to 12 MHz
Frequency Control:	Variable frequency oscillator
Selectivity:	-6 DB attenuation, 5 KHz minimum -50 DB attenuation, 20 KHz maximum
Sensitivity:	AM, 1 UV for 10 DB $\frac{\text{signal} + \text{noise}}{\text{noise}}$ CW, 1 UV for 10 DB $\frac{\text{signal} + \text{noise}}{\text{noise}}$
Image Rejection:	Better than -40 DB
Spurious Rejection:	Better than -40 DB
Noise and Hum Level:	Better than -40 DB

Table 2-1. Performance Specifications (CONT).

Automatic Gain Control:	Not more than 10 DB variation in output with RF input change from 3 UV to 0.01 volt Usable to 3 volts
Beat Frequency Oscillator:	Crystal controlled, 455 KHz
Calibration Oscillator:	Crystal controlled, 200 KHz
Audio Output Impedance:	8 ohms, suitable for low or medium impedance headphones
ANTENNA MATCHING UNIT	
The transceiver contains an antenna matching unit. This unit enables the transceiver to match the following antennas.	
15-foot whip antenna - Accessory item	
*Packset loaded whip - Accessory item	
Vehicular whip - Accessory item	
Long wire antenna - Accessory item	
*The accessory packset antenna also contains a matching unit. The transceiver matching unit is set to allow a match of approximately 20 ohms which is the approximate input impedance of the packset antenna. The packset antenna matching unit is then used for all further matching.	

SECTION III INSTALLATION AND ADJUSTMENT

3-1. UNPACKING. The equipment may be shipped in either export or domestic packing cases. In either event, no special unpacking procedures are necessary. When new equipment is received, select a location where the cases may be unpacked without exposure to the elements.

3-2. PRELIMINARY PROCEDURES. Complete the following steps before placing equipment in operation:

- a. Remove the moisture proof cover containing the power cable and accessory items.
- b. Loosen the front panel by rotating the five twist lock fasteners 1/4 turn counterclockwise. Slide unit out of case to expose interior. Check for possible damage that may have occurred during shipment. Report damage immediately to responsible personnel.

CAUTION

Do not attempt to place damaged equipment in service.

c. Refer to figure 7-3 in Section VII and note the location of the crystal sockets for crystals Y1 through Y6. Remove the crystal retaining bracket and insert the crystals into the appropriate sockets. Replace the crystal retaining bracket.

d. Replace unit in case.

e. Set transmitter function switch S2 in the OFF position.

f. Identify the power cable and connect to DC IN receptacle on the front panel.

3-3. ANTENNA. The antenna system for the transceiver is entirely dependent upon equipment application. If a doublet-type antenna is selected, it must present a 50-ohm load to the transmitter. Refer to the antenna discussion in Section IV (paragraphs 4-7 through 4-14 before deciding which antenna to install.

3-4. FUNCTIONS OF OPERATING CONTROLS. All controls utilized during normal operation of the transceiver are located on the front panel (figure 3-1). The control functions are listed in table 3-1.

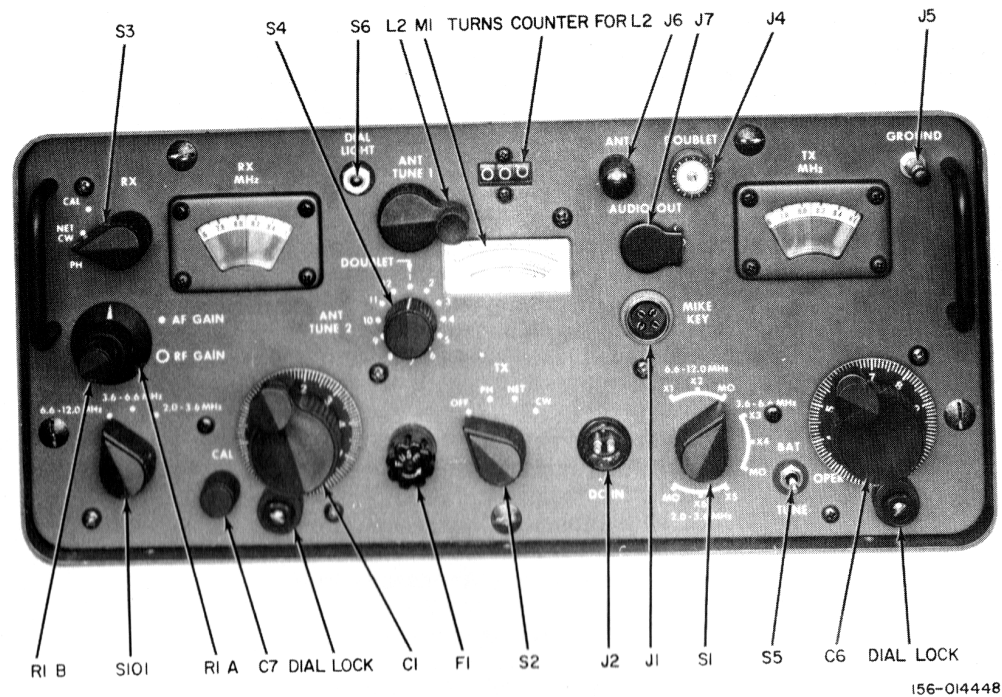

Figure 3-1. Operating Controls.

Table 3-1. Operating Control Functions.

Reference Designation	Item Name or Marking	Function
S3	CAL/NET CW/PH (Receiver function switch)	Selects CAL, NET CW, or PH mode of operation of the receiver.
S2	OFF/PH/NET/CW (Transmitter function switch)	Selects OFF, PH, NET, or CW mode of operation of the transmitter. When in the OFF position, the entire transceiver is inoperative.
C1	Receiver frequency control	Selects the operating frequency of the receiver. The frequency is indicated on the receiver RX MHz dial.
C6	Transmitter frequency control	Selects the operating frequency of the transmitter. The frequency is indicated on the transmitter TX MHz dial.
R1A R1B	RF GAIN control AF GAIN control	The receiver AF GAIN and RF GAIN controls are mounted on concentric shafts. The AF GAIN control (inside knob) adjusts the audio level applied to the earphones or speaker. The RF GAIN control (outside knob) varies the gain of the receiver RF and IF amplifiers. This control should be set to the fully clockwise position for all, but the strongest signals. Its purpose is to prevent receiver overload and AGC "pumping" on strong signals.

Table 3-1. Operating Control Functions (CONT).

Reference Designation	Item Name or Marking	Function																		
S101	Receiver band switch	Selects the appropriate range of frequencies that the receiver frequency control may tune. The switch has the following positions: 2-3.6 MHz, 3.6-6.6 MHz, and 6.6-12 MHz. The RX MHz dial displays the selected range.																		
S1	Transmitter band switch	Selects the desired range of frequencies or frequency of the transmitter. The switch has nine positions, three for each of the three bands (2-3.6 MHz, 3.6-6.6 MHz, 6.6-12 MHz). Positions X1 through X6 select crystals which control the transmitter output, and the MO position of each band permits the frequency to be controlled by the transmitter frequency control C6. The following relationship exists between the X position and the crystals: <table border="1" style="margin-left: auto; margin-right: auto;"> <thead> <tr> <th>Band</th> <th>Position</th> <th>Crystal</th> </tr> </thead> <tbody> <tr> <td rowspan="2">2-3.6 MHz</td> <td>X1</td> <td>Y1</td> </tr> <tr> <td>X2</td> <td>Y2</td> </tr> <tr> <td rowspan="2">3.6-6.6 MHz</td> <td>X3</td> <td>Y3</td> </tr> <tr> <td>X4</td> <td>Y4</td> </tr> <tr> <td rowspan="2">6.6-12 MHz</td> <td>X5</td> <td>Y5</td> </tr> <tr> <td>X6</td> <td>Y6</td> </tr> </tbody> </table>	Band	Position	Crystal	2-3.6 MHz	X1	Y1	X2	Y2	3.6-6.6 MHz	X3	Y3	X4	Y4	6.6-12 MHz	X5	Y5	X6	Y6
Band	Position	Crystal																		
2-3.6 MHz	X1	Y1																		
	X2	Y2																		
3.6-6.6 MHz	X3	Y3																		
	X4	Y4																		
6.6-12 MHz	X5	Y5																		
	X6	Y6																		
C7	CAL	Allows the receiver RF MHz dial to be accurately calibrated after receiver function switch S3 is placed in the CAL position.																		
S6	DIAL LIGHT	Illuminates receiver and transmitter dial scales when switch is depressed.																		
L2	ANT TUNE 1	Simulates the lengthening of the antenna. The revolutions of the shaft are numerically displayed on a counter dial. This control is used in conjunction with ANT TUNE 2 switch. The use of both controls are described in Section IV.																		
S4	ANT TUNE 2	Selects capacitors when used with ANT TUNE 1 control that form an L network enabling various antennas and antenna lengths to be used with the transceiver.																		
S5	BAT/OPER/TUNE	In the BAT position, the meter M1 indicates battery voltage. The indication is more meaningful if the voltage is read during a transmit period, either phone or CW mode of operation. In OPER position, the meter will indicate relative power output when transmitting and relative signal strength when receiving. In the TUNE position, the meter indicates the output of the antenna bridge. ANT TUNE 1 and ANT TUNE 2 are rotated until the meter reads zero or near zero output (refer to Section IV).																		

Table 3-1. Operating Control Functions (CONT).

Reference Designation	Item Name or Marking	Function
J4	DOUBLET	Coax receptacle for antennas cut to the operating frequency and presenting a resistive load to the transceiver. Also used for base loaded short vertical antennas such as Model A-45. ANT TUNE 1 control should always be set fully clockwise, 000 on turns counter, when using this connector. ANT TUNE 2 may still be used for proper matching.
J5	GROUND	Used to connect to ground radials or other suitable ground.
J6	ANT	Screw type terminal used for single wire "lead-in" antennas which require the use of ANTENNA TUNE 1 and ANTENNA TUNE 2 for proper matching.

SECTION IV OPERATION

4-1. GENERAL. The purpose of this section is to familiarize the individual with the operation of the Model TR-9 Transceiver. Proper operation is dependent upon the transceiver being installed and adjusted in accordance with the instructions contained in this manual. Refer to figure 3-1 for front panel designations.

4-2. TRANSCEIVER OPERATION. To prepare the transceiver for operation, perform the following steps:

- a. Connect a suitable antenna to the transceiver.
- b. Connect a 12.6 VDC (nominal) power source, either a storage battery or a suitable power supply, to the DC IN receptacle J2 by utilizing the power cable supplied with the transceiver. Connect a speaker or headphone set to the AUDIO OUT jack J7. Also, connect a microphone or CW key to the MIKE/KEY jack J1. Set the BAT/OPER/TUNE switch S5 to the OPER position.
- c. Apply power to the equipment by turning transmitter function switch S2 to the desired mode of operation: PH (phone) or CW (continuous wave keying).

- d. Rotate receiver function switch S3 to the same mode of operation as in step c.
- e. Rotate transmitter band switch S1 to the desired band. Then set switch to one of the crystal positions if crystal control is required; or set switch to the MO (master oscillator) position if variable frequency control is required. Steps e through j describe MO operation.

- f. Set receiver band switch S101 to the same frequency band position as in step e.

NOTE

Assure that the locking devices on the receiver frequency control C1 and the transmitter frequency control C6 are rotated fully counterclockwise.

- g. Set receiver frequency control C1 near the desired receive and transmit frequency.
- h. Set receiver function switch S3 to the CAL position. Turn receiver frequency control C1 to the nearest multiple of 200 KHz and adjust CAL control C7 for a zero beat note. Return receiver function switch S3 to the same mode of operation used in step c.
- i. Turn receiver frequency control C1 to the exact required frequency.

NOTE

When netting the transmitter to the receiver, RF GAIN control R1A should always be at a minimum setting, just sufficient to hear the beat note. If a higher setting is used, the transmitter may unknowingly be netted to a spurious signal. If signals are interfering with the netting operation, temporarily disconnect the antenna.

j. If the transmitter is to operate on the same frequency as the receiver, set transmitter function switch S2 to the NET position and the receiver function switch S3 to the NET CW position. Rotate transmitter frequency control C6 to approximately the required frequency. As the control passes the required frequency, a beat note will be heard in the headphones or the speaker. Continue adjusting the transmitter control C6 until a zero beat note is obtained. The transmitter is now set to the same frequency as the receiver. Return transmitter function switch S2 and receiver function switch S3 to the desired mode of operation.

k. Crystal-controlled operation requires that the receiver be netted to the transmitter, as described in steps l and m.

l. Set the transmitter band switch S1 to the appropriate band and crystal position. With the antenna connected and the transmitter function switch S2 in the PH (phone) position, press the microphone push-to-talk switch and turn the transmitter frequency control C6 to the frequency of the chosen crystal. Further adjust the transmitter frequency control C6 until the meter indicates maximum output. The transmitter is now crystal controlled and should be matched to the antenna. Also, refer to paragraph 4-7.

m. Release the push-to-talk switch and turn the transmitter function switch S2 to the NET position and the receiver function switch S3 to the NET CW position. Place the receiver band switch S101 to the same frequency band as the transmitter. As the control passes the required frequency, a beat note will be heard. Continue adjusting the receiver frequency control C1 until a zero beat is obtained. The receiver is now on the same frequency as the transmitter.

n. Return the transmitter and receiver function controls (S2 and S3) to the PH or CW position as required.

4-3. MICROPHONE OPERATION (MASTER OSCILLATOR). The following procedure describes microphone operation of the transceiver when

using the MO (master oscillator). Perform this procedure after completing steps a through j of paragraph 4-2.

a. Load the transceiver to the antenna (refer to paragraph 4-7).

b. Set the transmitter function switch S2 to the PH position and the receiver function switch S3 to the PH position. Press the microphone push-to-talk switch and speak into the microphone in a normal speaking voice. When the push-to-talk switch is released, the transceiver automatically returns to the receive mode.

c. Receiver gain is adjusted with the AF GAIN control R1B. The RF GAIN control R1A should normally be fully clockwise and only be readjusted in the presence of strong signals which overload the receiver.

NOTE

Always return the RF GAIN control R1A to the fully clockwise position. When this control is not fully clockwise, the sensitivity of the receiver is reduced, and weaker signals may not be heard.

4-4. MICROPHONE OPERATION (CRYSTAL CONTROL). The following procedure describes microphone operation of the transceiver during crystal-controlled operation. Perform this procedure after completing steps k through m of paragraph 4-2.

a. Set transmitter function switch S2 and receiver function switch S3 to the PH position. Press the microphone push-to-talk switch and speak into the microphone in a normal speaking voice. When the push-to-talk switch is released, the transceiver automatically returns to the receive mode.

b. Receiver gain is adjusted with the AF GAIN control R1B. The RF GAIN control R1A should normally be fully clockwise and only be readjusted in the presence of strong signals which overload the receiver.

NOTE

Always return the RF GAIN control R1A to the fully clockwise position. When this control is not fully clockwise, the sensitivity of the receiver is reduced, and weaker signals may not be heard.

4-5. CW OPERATION (MASTER OSCILLATOR). The following procedure describes CW operation of the transceiver while using the MO (master oscillator). Perform this procedure after completing steps a through j of paragraph 4-2.

a. Load the transceiver to the antenna (refer to paragraph 4-7).

b. Set the transmitter function switch S2 to CW and the receiver function switch S3 to the NET CW.

c. Connect the CW key to the MIKE/KEY jack J1. When the key is pressed, the transmitter is operating, and a sidetone will be heard in the headphones or speaker. The volume of the sidetone may be adjusted with the AF GAIN control R1B. However, the AF GAIN control should normally be adjusted to control the gain of the received signal. In this condition, the sidetone volume is suitable for most operators. When the key is released the transceiver automatically returns to the receive mode.

d. Receiver gain is adjusted with the AF GAIN control R1B. The RF GAIN control R1A should normally be used only in the presence of strong signals. Strong signals will cause a "pumping" sound due to the action of the automatic gain control. To eliminate this condition, turn the RF GAIN control R1A counterclockwise until the "pumping" ceases.

4-6. CW OPERATION (CRYSTAL CONTROL). The following procedure describes CW operation of the transceiver during crystal-controlled operation. Perform this procedure after completing steps k through m of paragraph 4-2.

a. Load the transceiver to the antenna (refer to paragraph 4-7).

b. Set the transmitter function switch S2 to CW and the receiver function switch S3 to the NET CW.

c. Connect the CW key to the MIKE/KEY jack J1. When the key is pressed, the transmitter is operating, and a sidetone will be heard in the headphones or speaker. The volume of the sidetone may be adjusted with the AF GAIN control R1B. However, the AF GAIN control should normally be adjusted to control the gain of the received signal. In this condition, the sidetone volume is suitable for most operators. When the key is released, the transceiver automatically returns to the receive mode.

d. Receiver gain is adjusted with the AF GAIN control R1B. The RF GAIN control R1A should normally be used in the presence of strong signals. Strong signals will cause a "pumping" sound due to the action of the automatic gain

control. To eliminate this condition, turn the RF GAIN control R1A counterclockwise until the "pumping" ceases.

4-7. ANTENNA TUNER. The TR-9 Transceiver antenna tuner is designed to match a wide range of antennas. The ANT TUNE 1 control functions to electrically lengthen the antenna to achieve resonance. The ANT TUNE 2 switch S4 is omitted from the circuit in position 1. Positions 2 through 12 introduce capacitances which achieve correct matching to the antenna. When the BAT/OPER/TUNE switch S5 is in the TUNE position, a bridge circuit measures the standing wave ratio on the antenna. A null point indicates correct matching. This method of matching (a bridge in series with the antenna) is accurate and should not be confused with the type of indicator which indicates power output. The correct antenna matching is indicated by a minimum meter reading. Do not tune for maximum reading, as continued operation in this manner may lead to component failure. The central position of the BAT/OPER/TUNE switch S5 is OPER (operate), which allows the meter to read relative power output. This reading is accurate only when the antenna is matched to the transceiver and may actually increase when the antenna is out of tune. This position indicates that the transmitter is delivering power to the load.

CAUTION

Do not, under any circumstances, use the relative power readings to tune the antenna. The indications will be misleading and may lead to component failure.

4-8. DOUBLET ANTENNA. The doublet antenna should be cut to the proper length as given by the formula:

$$\lambda/2 \text{ Dipole Overall Length in feet} = \frac{468}{\text{frequency (MHz)}}$$

The coaxial cable feedline may be any convenient length but should be perpendicular to the horizontal for best results. Figure 4-1 illustrates a typical antenna installation, and table 4-1 provides approximate lengths for given frequencies. Connect the antenna to the DOUBLET coaxial socket on the front panel. Set the ANT TUNE 1 control to 000 and the ANT TUNE 2 switch S4 to 1 or DOUBLET. When the transmitter function switch S2 is set to PH position and the microphone push-to-talk switch is depressed and the BAT/OPER/TUNE switch S5 is set to TUNE, the meter should show a near zero reading, indicating a proper match to the antenna. If not, adjust the antenna length until the null is obtained.

Table 4-1. Approximate Lengths for Given Frequencies on Typical Antenna Installation.

Frequency Range (MHz)	$\lambda/2$ Length Feet	$\lambda/2$ Length Meters	Frequency Range (MHz)	$\lambda/2$ Length Feet	$\lambda/2$ Length Meters
2.0 - 2.2	222	68	4.0 - 4.5	110	33.5
2.2 - 2.4	203	63	4.5 - 5.0	99	30
2.4 - 2.6	187	57	5.0 - 6.0	85	26
2.6 - 2.8	173	53	6.0 - 7.0	72	22
2.8 - 3.0	161	49	7.0 - 8.0	62	19
3.0 - 3.3	148	45	8.0 - 10.0	52	16
3.3 - 3.6	135	41	10.0 - 12.0	42	13
3.6 - 4.0	123	37.5			

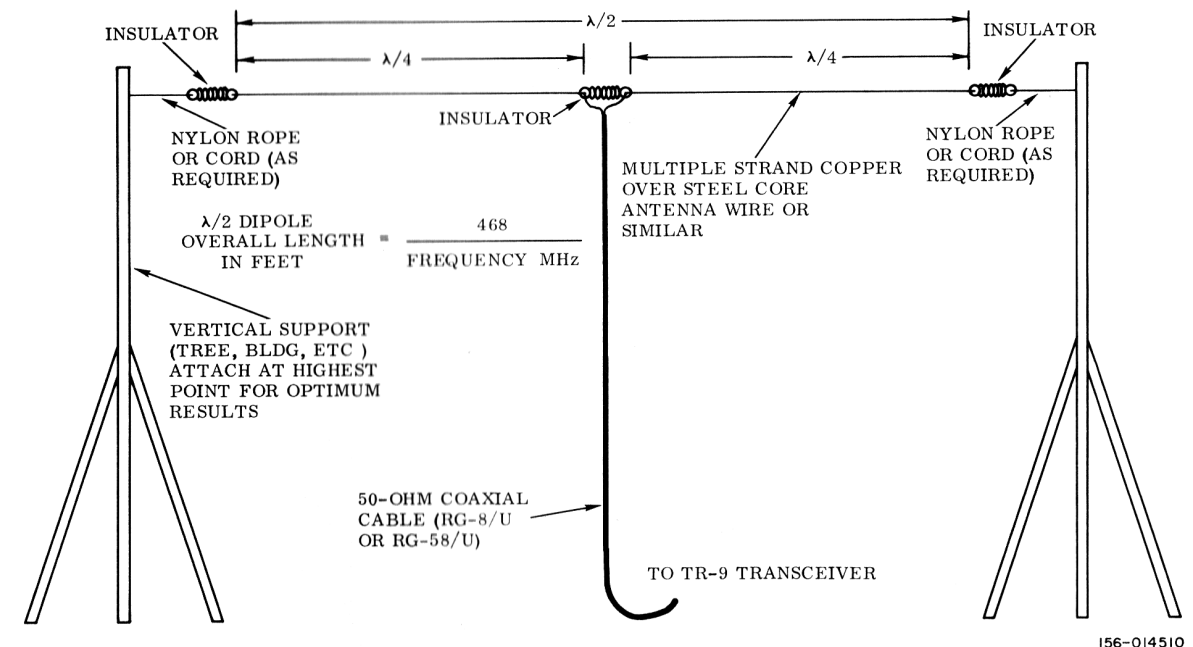

Figure 4-1. Typical Antenna Installation.

Table 4-4. Antenna Tuner Settings for Fifty-Foot Sloping Antenna Operation.

Frequency MHz	TUNE 1	TUNE 2	Frequency MHz	TUNE 1	TUNE 2
2.0	210	6	5.6	090	8
2.2	190	6	5.8	080	8
2.4	170	6	6.0	110	7
2.6	180	5	6.2	100	7
2.8	160	4	6.4	110	6
3.0	160	1	6.6	100	6
3.2	140	1	7.0	130	5
3.4	110	1	7.5	130	4
3.6	090	1	8.0	120	3
3.8	070	1	8.5	120	2
4.0	030	1	9.0	100	2
4.2	030	9	9.5	100	1
4.4	050	10	10.0	090	1
4.6	060	10	10.5	070	1
4.8	070	9	11.0	060	1
5.0	060	9	11.5	050	2
5.2	070	9	12.0	040	3
5.4	070	9			

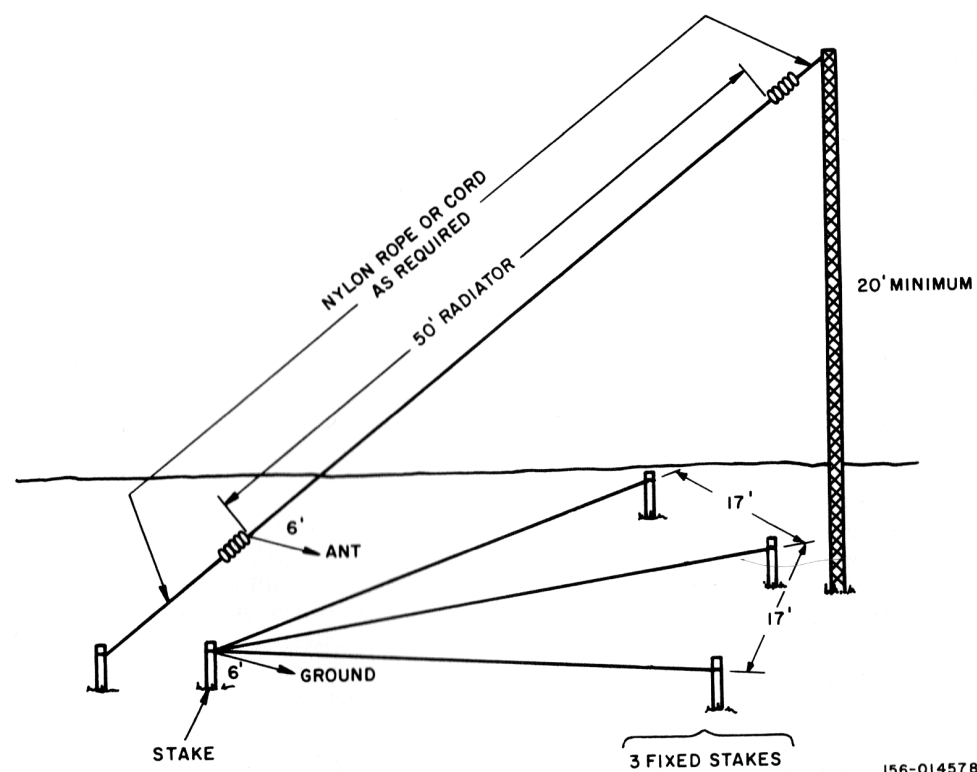

Figure 4-3. Fifty-Foot Sloping Antenna Installation.

4-14. OPERATING THE PACKSET ANTENNA. The Packset Antenna will operate from 2 to 9 MHz. To use the packset antenna, proceed as follows:

- Fit the packset antenna to the DOUBLET coaxial socket, and fit the set to the body. It is important to be wearing the set before tuning adjustments are made.
- Set the transceiver to the required frequency and band of operation.
- Set ANT TUNE 1 control to 000.
- Set ANT TUNE 2 switch S4 according to table 4-5.
- Adjust the loading coil of the antenna for maximum receiver noise. If the frequency is low, the antenna should be tuned in the direction indicated on the antenna housing. If the frequency is high, tune the antenna in the opposite direction.

f. Set BAT/OPER/TUNE switch to TUNE, the transmitter function switch S2 to PH, and press the push-to-talk microphone switch. Adjust the antenna for a minimum reading on the meter. If a proper null cannot be obtained, switch ANT TUNE 2 switch S4 to an adjacent position and readjust the antenna until a null is obtained. The ANT TUNE 2 chart is intended as a guide only, and this control setting will vary according to the terrain and the size of the individual wearing the set. Do not adjust the antenna with the BAT/OPER/TUNE switch in the OPER position or damage may result to the transceiver.

g. For greater antenna efficiency, a grounding system is recommended when using the packset antenna. The grounding system consists of 10 feet of copper wire connected to the ground post on the front panel of the transceiver, with the loose end trailing on the ground. A more efficient system would be to connect the loose end of the wire to a metal stake driven into the ground.

Table 4-5. Antenna Tuner Settings for Packset Antenna Operation.

Set ANT TUNE 1 to 000		
Set ANT TUNE 2 to	10 at 2.1 MHz	8 at 4.2 MHz
	10 at 2.5	8 at 5.0
	10 at 3.0	6 at 6.0
	10 at 3.6	6 at 7.0
		4 at 8.0 MHz
		4 at 9.0

SECTION V THEORY OF OPERATION

5-1. INTRODUCTION. Study the following paragraphs carefully for a thorough understanding of the theory of operation. A block diagram (figure 5-1) and schematic diagrams (figure 5-2) are included in this section.

5-2. THEORY OF OPERATION (RECEIVER). The receiver portion of the Model TR-9 Transceiver is a completely solid-state superheterodyne receiver. A high degree of selectivity is obtained through the use of a mechanical filter. Excellent CW operation is accomplished by the utilization of a balanced demodulator circuit in which the beat frequency oscillator is contained. This type of detector circuit gives excellent output without the need for adjustment of RF gain controls, except in cases of extreme overload. The RF amplifier is a bipolar transistor operated in the common-emitter mode. A wide band toroidal input transformer transforms the antenna impedance to that of the tuned circuits T101, T102 and T103. The secondary windings on these transformers are coupled through the band switch S101

to the base of the RF amplifier. The output tuned circuits T104, T105 and T106 couple the signal to the mixer Q102. Note, the collector circuit of the RF amplifier Q101 and the base circuit of the mixer Q102 share a common secondary winding. The oscillator utilizes a field effect transistor Q103 in order to obtain a high degree of oscillator stability. A zener diode CR101 controls the oscillator voltage, allowing large changes of supply voltage without excessive frequency shift. Transistor Q104 isolates the oscillator from the mixer. The mixer stage Q102 produces the 455 KHz IF, which is fed to L701 on the Noise Blanking PC701. The IF signal is coupled to the base of IF amplifier Q703, through C705 and diode CR704. Pulse type noises appearing on the IF signal are detected by diodes CR701 and CR702. The noise pulses are amplified by Q701 and Q702, and are applied to the anode of diode CR704. The noise pulses are of sufficient amplitude to momentarily switch "off" diode CR704, thereby preventing the noise pulses from reaching the

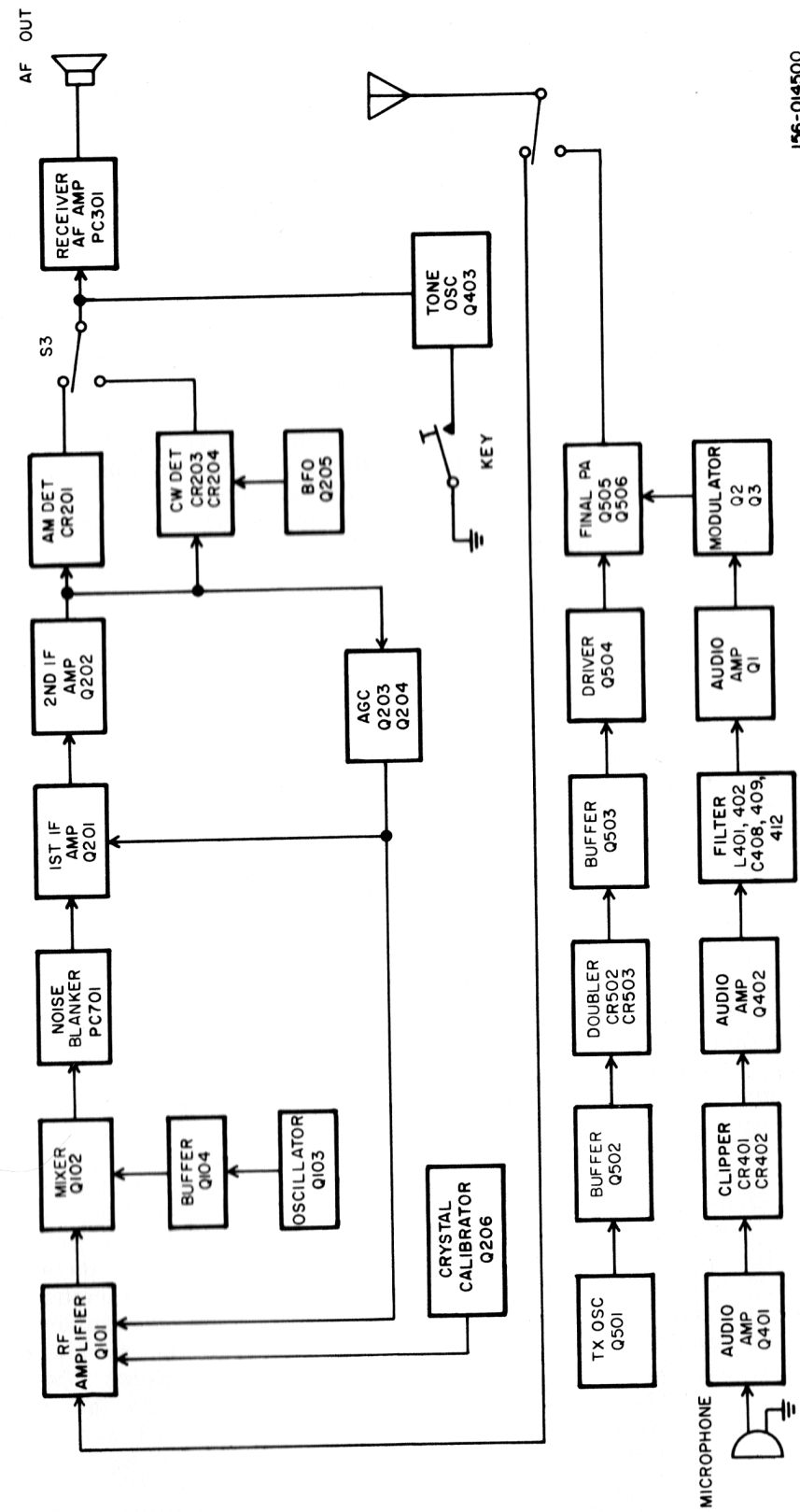

156-014500

Figure 5-1. Overall Block Diagram.

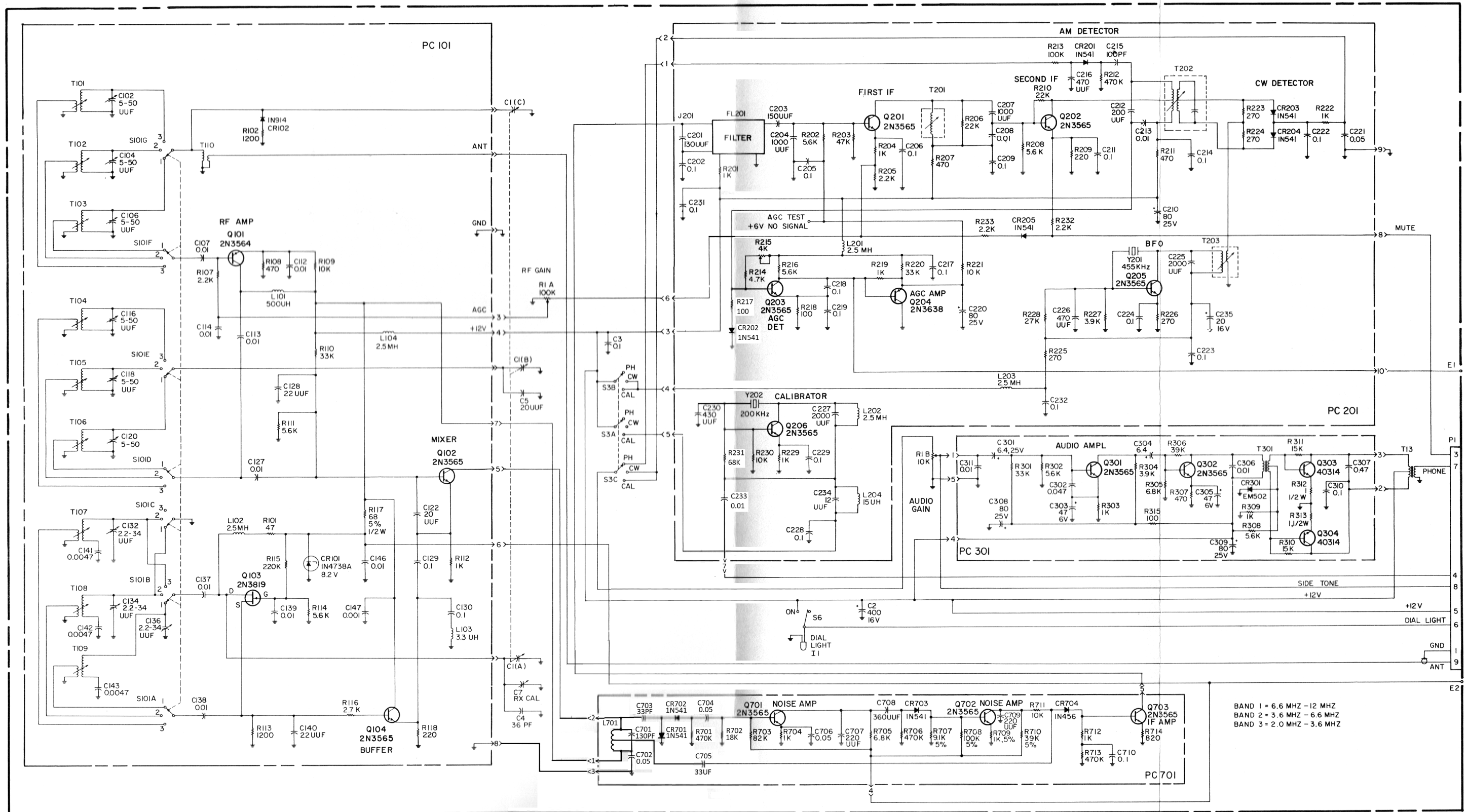

best possible scan on available equipment without destroying original document binding.

156-00102C
SHEET 1 OF 2

Figure 5-2. Schematic Diagram (Sheet 1 of 2).

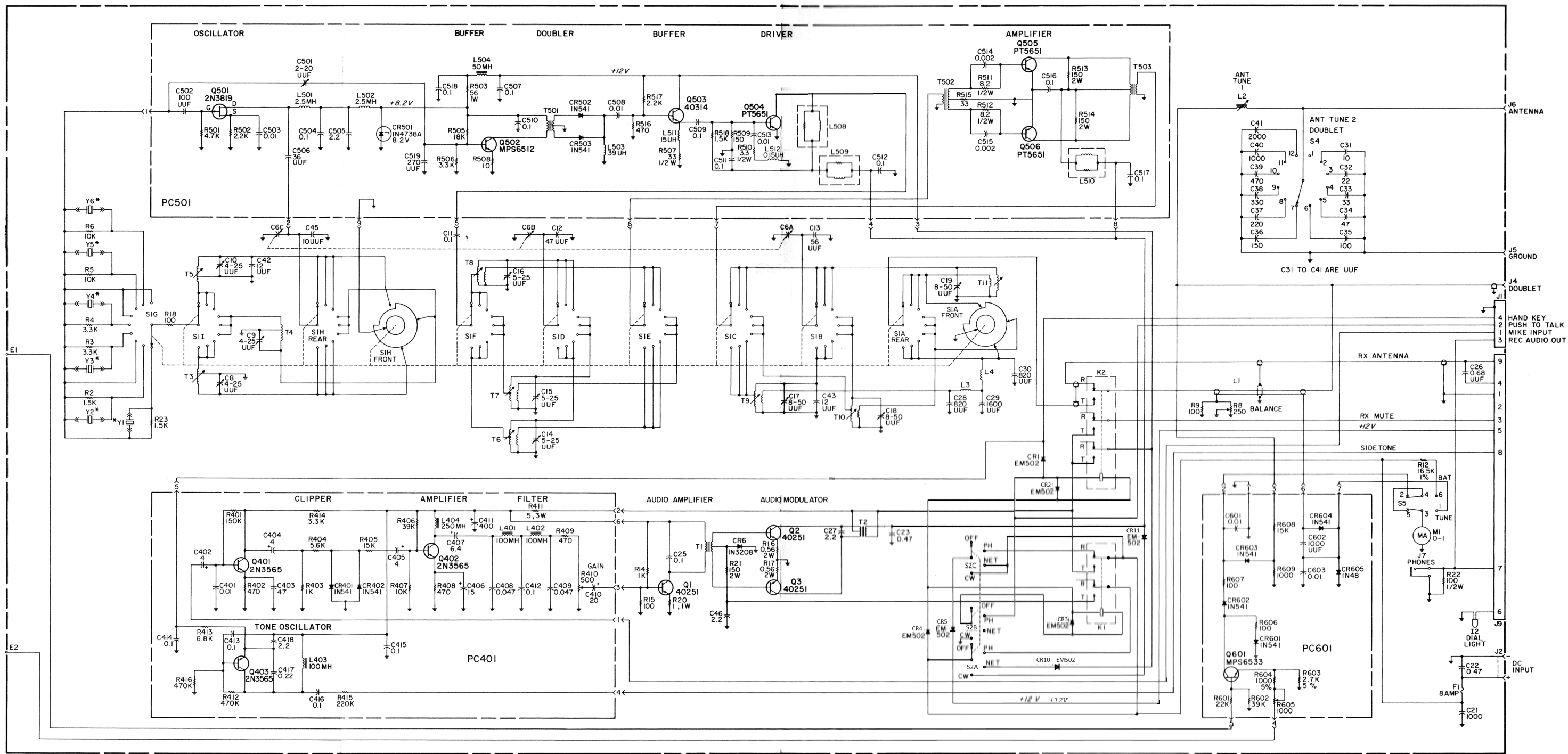

- NOTES:
- UNLESS OTHERWISE INDICATED, ALL RESISTORS ARE IN OHMS, * 10%, 1/4 WATT. ALL CAPACITORS ARE IN UF.
 - BANDSWITCH IS SHOWN IN BAND 1, 6.6 TO 12 MHz.
 - * NOT SUPPLIED WITH EQUIPMENT.

155-00102C
SHEET 2 OF 2

Figure 5-2. Schematic Diagram (Sheet 2 of 2).

base of IF amplifier Q703. The noise blanker is quite effective in eliminating receiver interference caused by pulse type noises generated from vehicular ignition systems. The output of IF amplifier Q703 is fed to mechanical filter FL201. The output from the mechanical filter is coupled to Q201. This stage, in turn, feeds the second IF amplifier through transformer T201. The second IF amplifier Q202 feeds the balanced demodulator CR203, CR204 and AM detector CR201. In addition, the capacitor divider on the primary of T202 feeds the AGC detector Q203. This latter stage operates as a class B detector. The knee of the AGC voltage is controlled by variable resistor R215. This control adjusts the bias on Q203. CR202, a germanium diode in the base circuit of Q203, helps to stabilize the stage against excessive temperature variations. Q203 is direct coupled to Q204 which operates as an emitter-follower. Note that this stage is a PNP transistor. The compound connection allows a fast-attack, slow-release form of automatic volume control which acts as follows. When a signal is applied to the base of Q203, which is biased near the bottom portion of its input-output curve, only the positive-going half cycles cause amplification. As a result, the voltage at the collector of Q203 decreases on application of a signal. Thus, the voltage at the base of Q204 also decreases with respect to ground. However, the amplifier Q204 is a PNP stage. Therefore, the current through Q204 increases. The impedance of Q204 is very low, and the high negative voltage through the transistor is applied to the ungrounded end of C220, the AGC storage capacitor. This voltage is then fed by the AVC line to the base of the first amplifier Q201. The first amplifier doubles as a DC amplifier. The output of Q201 is taken from the emitter circuit to control the AGC on the base of RF amplifier Q101. When the signal ceases, transistor Q204 creates an open circuit. Capacitor C220 charges through R220. The delay time is, therefore, determined by the capacitor C220 and resistor R220. The AGC voltage developed by Q203 is also applied to the base of the DC amplifier Q601. This amplifier controls the current through meter M1 and will show the relative strength of received signals. The beat frequency oscillator Q205 operates at 455 KHz and supplies the BFO voltage to the CW balanced demodulator, comprised of the diodes CR203 and CR204. Output from the CW detector and the AM detector CR201 is selected by switch S3 which is coupled to Q301 through AUDIO GAIN control R1B. The audio amplifier stages are on printed circuit board PC301. Two common emitter stages drive push-pull transistors in the class B mode. Diode CR301 stabilizes the output stage against temperature variations. Either headphones or speaker may be used with the receiver. A calibrator is provided in order that the receiver dial may be adjusted

to the correct frequency. Capacitor C7 enables the dial to zero beat with the calibrator. The calibrator oscillator generates a crystal-controlled signal every 200 KHz. Inductor L204 and capacitor C234 increases the calibrator harmonic output. During the transmit period, the receiver is rendered inoperative by feeding a mute voltage to the emitter of the second IF amplifier, Q202 and through diode gate CR205 to the AGC line to render the first IF amplifier Q201 and the RF amplifier inoperative. The audio amplifier is not muted in the CW condition. This is to allow the CW sidetone to be amplified and transmitted to the speaker or headphones.

5-3. THEORY OF OPERATION (TRANSMITTER). The transmitter portion of the TR-9 Transceiver is completely solid state. Field effect transistor Q501 is a tuned oscillator that operates at half the transmitter output frequency. A link winding in the drain output circuit provides feedback to the transistor gate. When crystal-controlled operation is required, a crystal is inserted in series with the feedback link winding. To obtain oscillation, the tuned circuit must be tuned at or near the crystal frequency. A buffer stage Q502 isolates the oscillator from the doubler circuit. Both the buffer and the oscillator stages are supplied from zener diode CR501 with a regulated DC voltage. The doubler consists of diodes CR502 and CR503, operation of which is similar to that of a full wave rectifier circuit. If the diodes are matched, the original frequency is cancelled out and the output frequency is twice that of the original. A second buffer stage Q503 operates as an emitter-follower to provide a "stiff" drive source to amplifier Q504. Transistor Q504 operates in a class AB condition. Tuned circuits in the collector circuit select and pass the wanted frequency to the push-pull class C output stage. The signal is introduced to output stage Q505 and Q506 through wide band transformer T502. The resistor-capacitor combinations, in series with the base leads, allow a constant current drive to the transistors, assuring a higher degree of modulation. A second wide band transformer, T503, converts the push-pull output to a single ended output which is then applied to the output tuned circuits in the normal manner. The signal from output stages Q505 and Q506 is fed to the tuned circuits and then to the antenna through antenna bridge L1. When a doublet type of antenna is not required, the output is fed through an antenna tuner consisting of an L network formed by rotary inductor L2 and capacitors C31 through C41. The entire bridge components consist of R9, R8, L1, C602, C603, CR604 and CR605. Diode CR604 samples the reflected currents. CR605 tends to limit the voltage logarithmically to prevent the meter from reading off scale, while

capacitor C602 damps meter frequency sensitivity. To enable the operator to know that the transmitter is delivering power to the antenna, output at the antenna is sampled by diode CR603 and is connected to the meter when switch S5 is in the OPER position. This reading is only relative, and does not indicate anything other than the fact that the transmitter is delivering power to the load.

5-4. THEORY OF OPERATION (MODULATOR). Output from the dynamic microphone is amplified by transistor Q401. This amplified signal is clipped by diode clippers CR401 and CR402, amplified by Q402, and fed to the low pass fil-

ter comprised of C408, L401, C409, L402, and C412. The filter removes harmonics generated in the clipping process. Amplifier Q1 drives a pair of class B modulators, Q2 and Q3. Approximately 20 watts of audio power is generated to modulate RF driver Q504 and final amplifiers Q505 and Q506. Diode CR6 regulates the idle current against temperature and voltage variations. In order to provide a sidetone in the headphones or speaker, a tone oscillator is actuated when the transmitter oscillator is keyed and the transmitter function switch S2 is in the CW position. The sidetone oscillator is located on printed circuit board PC401, which also contains the transmitter low level audio and clipper stages.

SECTION VI CALIBRATION AND ALIGNMENT PROCEDURES

6-1. GENERAL. This section of the manual describes calibration and alignment procedures for the receiver and transmitter sections of the transceiver. Refer to figures 6-1 through 6-4.

6-2. TEST EQUIPMENT. The following test equipment is required to perform calibration and alignment procedures:

- a. Regulated 12.6-volt DC power supply capable of a 5-ampere output
- b. Signal generator (0.455 - 12.0 MHz range)
- c. DC vacuum tube voltmeter (VTVM)
- d. AC voltmeter
- e. Calibrated general coverage receiver
- f. Frequency counter (optional)
- g. RF wattmeter, Bird Model 43 or equivalent
- h. Dummy load, 50-ohm non-inductive resistance, capable of dissipating 20 watts
- i. Oscilloscope
- j. 8-ohm speaker

6-3. REMOVAL OF CHASSIS. The chassis is readily removed from the cabinet by rotating the five twist-lock fasteners 1/4 turn counterclockwise and sliding the unit out of the case.

6-4. IF AMPLIFIER AND BFO ALIGNMENT. Connect signal generator to terminal NO. 5 on

PC101 through a 0.01 UF capacitor in series with a 10K ohm resistor. The following procedures are required for alignment:

- a. Connect the AC voltmeter across the AUDIO OUT jack J7.
- b. Adjust signal generator to 455 KHz, modulated 30 percent.
- c. Adjust L701 and T201 for maximum output.
- d. Remove the modulation from the generator and set the receiver function switch S3 to NET CW position. Adjust signal generator slightly away from 455 KHz until an audio beat note is heard.
- e. If a beat note is not heard, adjust T203 until the beat note is audible. Tune the core of T203 outward from the coil until oscillation ceases. Then tune the core inward until positive oscillation is obtained.
- f. With the BFO operating properly, adjust the top and bottom cores of T202 for maximum output indicated on the AC voltmeter.

6-5. CALIBRATION AND ALIGNMENT (RECEIVER). Table 6-1 provides receiver calibration and alignment frequencies for each band, and the capacitor and coil involved in each alignment. To calibrate and align the RF section of the receiver, proceed as follows:

- a. Connect output from signal generator (50-ohm output) to the DOUBLET antenna jack.
- b. Adjust ANT TUNE 1 control until counter reads 000. Set ANT TUNE 2 switch S4 to number 1 or DOUBLET position.

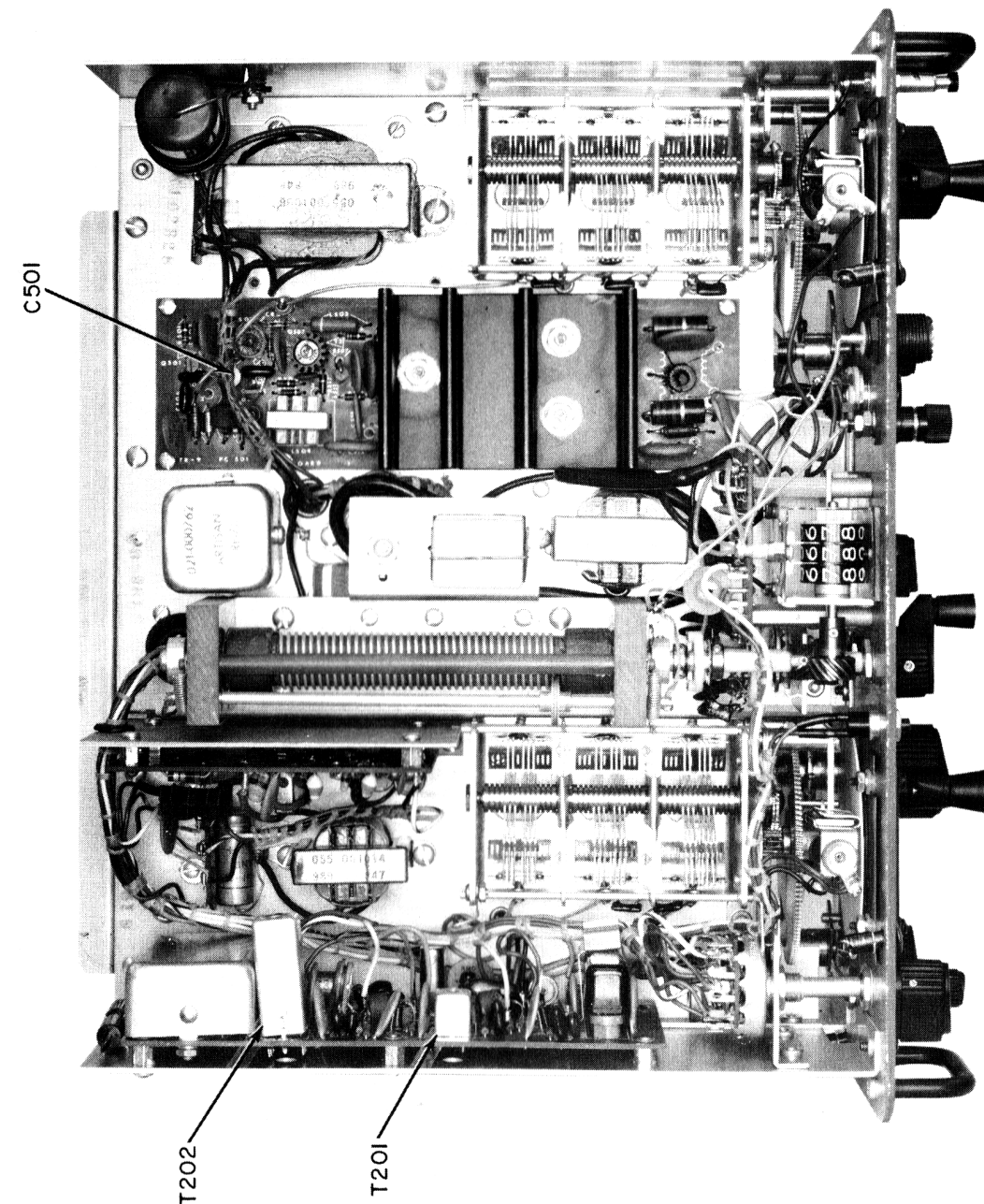

Figure 6-1. Adjustment Locations (Top View).

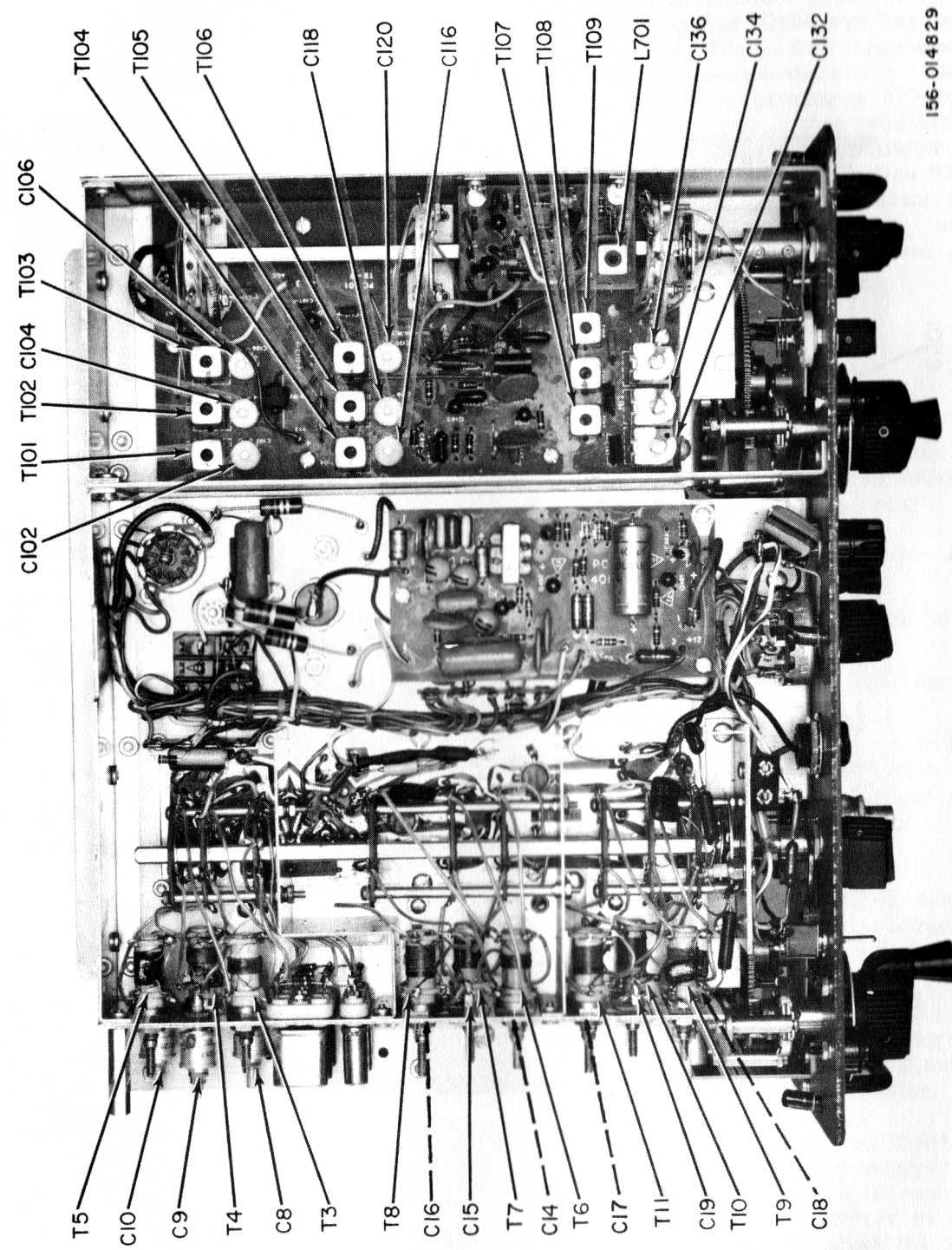

Figure 6-2. Adjustment Locations (Bottom View).

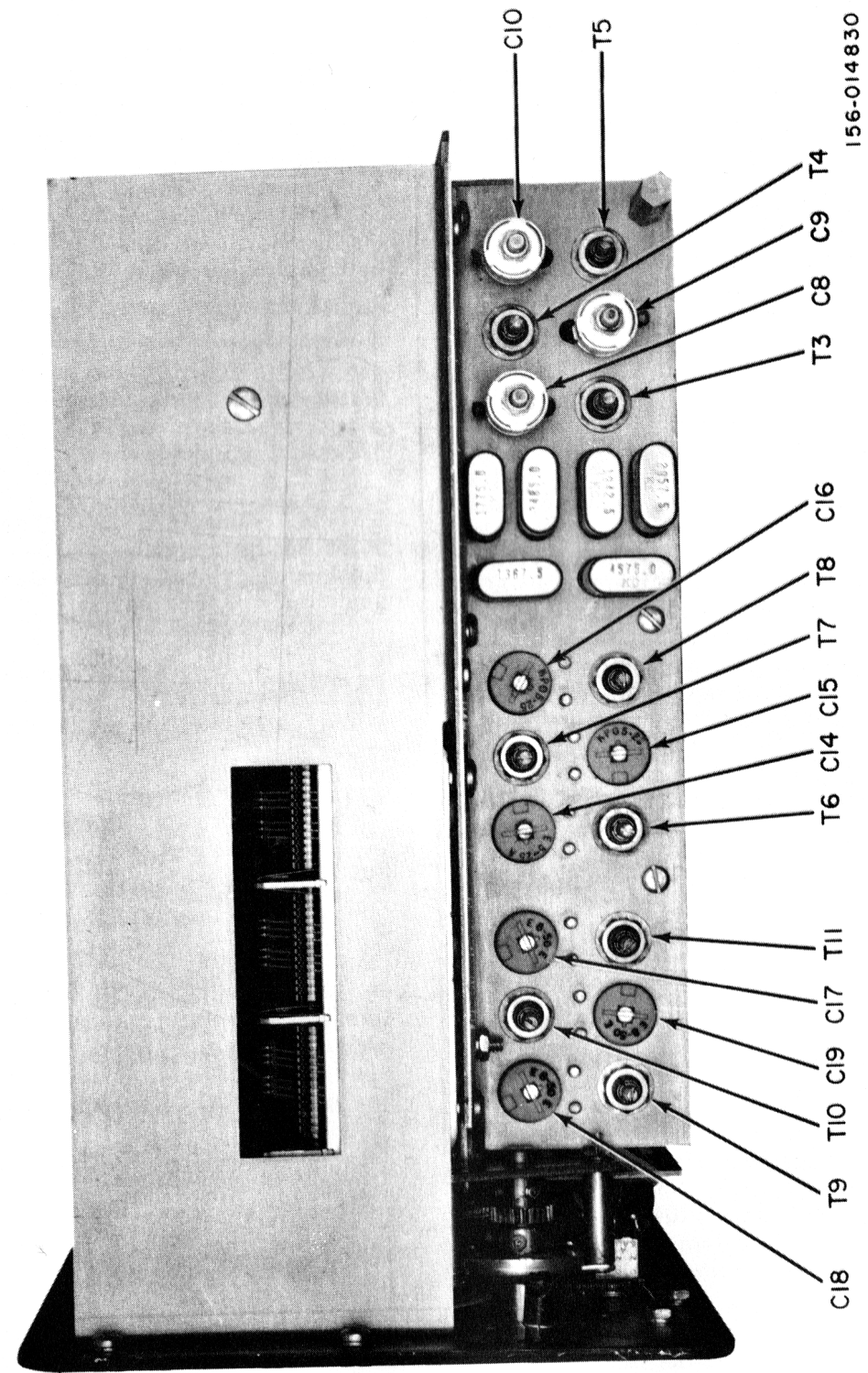
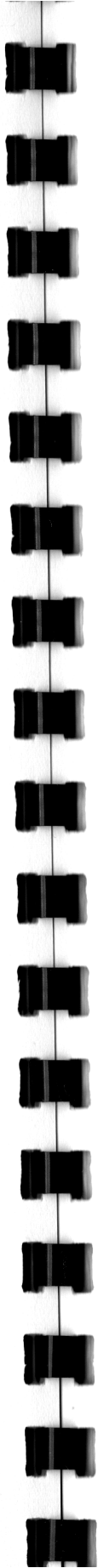

Figure 6-3. Adjustment Locations (Right Side View).

c. Set receiver band switch S101 band to the desired band for alignment and calibration.

d. Set signal generator to the low frequency calibration point and the unmodulated position. Switch the receiver to the NET CW position, and tune receiver dial until beat note from signal generator is heard. For example, assume that the band of 2.0-3.6 MHz is to be aligned and calibrated. If the dial reading is not correct, adjust the slug in T107 until the dial reads the correct frequency (in this instance 2.0 MHz). Set signal generator to high frequency calibration point (3.6 MHz) and adjust C132 until the dial reading is correct. A zero beat note indicates accurate adjustment.

e. The high and low frequency adjustments are interrelated, and it is necessary to alternate between the low and the high ends, adjusting the inductance value at the low frequency calibration point and the capacitance at the high frequency point. Maintain signal generator voltage as low as possible to stay below the AGC knee. It is advisable to sweep across the band and ascertain that the calibration has been made to the wanted signal, and not to a spurious or image signal. The same procedure is used on the two higher bands.

f. Set signal generator to the low frequency alignment point shown in table 6-1 and set the modulation percentage control to 30 percent. Turn the receiver function switch S3 to PH (phone) position.

g. Connect an AC voltmeter to the AUDIO OUT jack J7.

h. Rotate RF GAIN control R1A fully clockwise.

i. Adjust alignment components. For example, if the band of 2.0 - 3.6 MHz is being aligned, adjust T101 and T104 for maximum output on the meter. Maintain signal generator output at minimum voltage level.

j. Set signal generator to upper frequency alignment point and adjust (in the band of 2.0-3.6 MHz, for example) C102 and C116 for maximum output on the meter. The high and low frequency adjustments are interrelated, and it is necessary to move alternately between the high and the low ends, adjusting the inductance at the low frequency alignment points and the capacitance at the high frequency alignment points.

CAUTION

Beware of spurious and image signals. The image signal will be found 910 KHz above the wanted signal and under some circumstances, especially on the higher frequency band, it is possible to accidentally align the receiver to this frequency.

k. Repeat the above procedures on the two higher frequency bands.

6-6. AGC VOLTAGE ADJUSTMENT. The automatic gain control voltage must be preset for correct receiver operation. To accomplish this, proceed as follows:

a. Connect a DC VTVM to AGC-TEST point on IF amplifier module PC201. This is the larger printed circuit board in the receiver section above the chassis.

b. With no input signal applied to receiver, adjust R215 until +6 volts is obtained at the test point. This adjustment sets the "knee" of the AGC system.

NOTE

There will be a short time lag between the adjustment and the final meter reading.

6-7. SIGNAL STRENGTH METER ADJUSTMENT. Use the following procedures for proper adjustment:

a. Tune receiver to 7 MHz.

b. Feed a 10 UV signal into the receiver.

c. With S5 in OPER position, adjust R605 until meter M1 reads mid-scale.

6-8. CALIBRATION AND ALIGNMENT (TRANSMITTER). Table 6-2 provides transmitter calibration and alignment frequencies for each band, and the capacitor and coil involved in each alignment. To calibrate and align transmitter, proceed as follows:

a. Connect the outlet from the DOUBLET antenna jack J4 to a 50-ohm dummy load and wattmeter. Connect microphone to MIKE/KEY jack J1.

Table 6-1. Receiver Alignment and Calibration Frequencies and Alignment Components.

2.0 MHz - 3.6 MHz	
Calibration frequencies	2 MHz, 3.6 MHz
Calibration components	T107, C132
Alignment frequencies	2 MHz, 3.6 MHz
Alignment components	T101, T104, C102, C116
3.6 MHz - 6.6 MHz	
Calibration frequencies	3.6 MHz, 6.6 MHz
Calibration components	T108, C134
Alignment frequencies	3.6 MHz, 6.6 MHz
Alignment components	T102, T105, C104, C118
6.6 MHz - 12 MHz	
Calibration frequencies	6.6 MHz, 12 MHz
Calibration components	T109, C136
Alignment frequencies	6.6 MHz, 12 MHz
Alignment components	T103, T106, C106, C120

Table 6-2. Transmitter Alignment and Calibration Frequencies and Alignment Components.

2.0 MHz - 3.6 MHz	
Calibration and alignment frequencies	2 MHz, 3.6 MHz
Calibration components	T3, C8
Alignment components	T6, C14, T9, C17
3.6 MHz - 6.6 MHz	
Calibration and alignment frequencies	3.6 MHz, 6.6 MHz
Calibration components	T4, C9
Alignment components	T7, C15, T10, C18
6.6 MHz - 12 MHz	
Calibration and alignment frequencies	6.6 MHz, 12 MHz
Calibration components	T5, C10
Alignment components	T8, C16, T11, C19

b. Obtain a general coverage receiver fitted with a BFO, and couple this receiver loosely to the oscillator portion of the transmitter. For sufficient coupling, the receiver antenna wire is generally placed near the TR-9 transmitter oscillator.

c. First, align the band of 6.6 - 12 MHz. Set transmitter band switch S1 to the MO position in the band of 6.6-12 MHz. Tune the transmitter frequency control C6 to read 6.6 MHz on the frequency dial. Set the transmitter function switch OFF/PH/NET/CW to the NET/CW position. Adjust the ANT TUNE 1 control until the counter dial reads 000. Also, set the ANT TUNE 2 switch S4 to position 1.

d. Tune the coupled receiver until the signal from the transmitter oscillator is found and a zero beat tone is heard. If the frequency is not correct, adjust core of T5 until the frequency is correct with the dial reading. If greater accuracy is required, a frequency counter should be used.

NOTE

If a frequency counter is used, the frequency read will be one-half the required frequency. It is also important to remember that when using the receiver, signals will be heard at all harmonics of the oscillator. For example, if the dial is set at 6.6 MHz, signals may be heard at 3.3 MHz, 6.6 MHz, 9.9 MHz and so on. It is important that the correct frequency be used.

e. Set transmitter frequency control C6 and the coupled receiver to 12 MHz. If a signal is not heard, tune capacitor C10 until the signal is zero beat.

f. Since there is interaction between the low and the high ends of the band, the procedures described in steps d and e should be alternated. The core of T5 is adjusted only at the low frequency end of the dial, and the capacitance of C10 at the high frequency end of the dial.

g. Rotate transmitter function switch S2 to PH. Set transmitter dial to 6.6 MHz and press push-to-talk microphone switch. An output should be indicated on the wattmeter. Adjust alignment cores of T8 and T11 for maximum output.

h. Release microphone switch and tune the transmitter frequency control C6 to read 12 MHz on the frequency dial. Press the microphone switch and adjust alignment capacitors C16 and C19 for maximum output.

i. Since there is interaction between the low and the high ends of the band, the procedures described in steps g and h should be alternated.

The cores of T8 and T11 are adjusted only at the low frequency end of the dial and the capacitors C16 and C19 at the high end of the dial.

j. Tune transmitter frequency control C6 to read 10 MHz on the frequency dial. Press push-to-talk microphone switch and adjust drive capacitor C501, located on PC501, for 10 watts output. Repeat steps b through i.

k. To align the other two bands, use the procedures outlined in steps b through i using the capacitors and coils shown in table 6-2.

l. Switch back to the lowest frequency band and check the power output. Output should generally be limited to approximately 10 to 13 watts. Higher power outputs may cause difficulty in fully modulating the output. Correct adjustment will be obtained when the power output remains substantially constant from 2 MHz to approximately 10 MHz. Some fall-off in power output may be expected above 10 MHz. A compromise setting of drive control C501 may be required to stay reasonably close to recommended power output of 10 to 13 watts over the range of 2 to 10 MHz.

6-9. ANTENNA BRIDGE ADJUSTMENT. To adjust the antenna bridge, proceed as follows: connect a 50-ohm dummy load to the DOUBLET antenna jack J4. Set the transmitter band switch S1 to the MO position in the 3.6 - 6.6 MHz band. Tune the transmitter frequency control C6 to read approximately 6 MHz on the transmitter frequency dial. Set the BAT/OPER/TUNE switch to the TUNE position, actuate the transmitter, and adjust R8 until the meter reads zero.

6-10. MODULATION ADJUSTMENT. Adjustment of the modulation level should be undertaken only after the transmitter has been calibrated and aligned. This is accomplished as follows:

a. Connect a 50-ohm dummy load to the DOUBLET antenna jack. Set ANT TUNE 1 control until the dial reads 000 and rotate ANT TUNE 2 switch to position 1. Any convenient frequency in the band of 3.6-6.6 MHz may be used.

b. Set transmitter function switch S2 to PH and observe that the transmitter is functioning correctly.

c. Connect an oscilloscope to the transmitter output and set the oscilloscope vertical amplifiers to 2 cm or half of the amplitude normally displayed.

d. Whistle into the microphone and adjust the audio gain control R410 until the carrier is reduced to zero, but not actually broken between each cycle of superimposed audio. If the carrier is 100-percent modulated (figure 6-4), the oscilloscope amplitude will exactly double. The ratio of increased amplitude to carrier amplitude is a measurement of the modulation per-

centage. Because the input to the final amplifier varies somewhat across each band, and from band to band, a compromise setting must be found. Overmodulation will cause severe interference to other channels; undermodulation will not allow the signal to pass during noisy situations. A good compromise setting is usually above 70 percent.

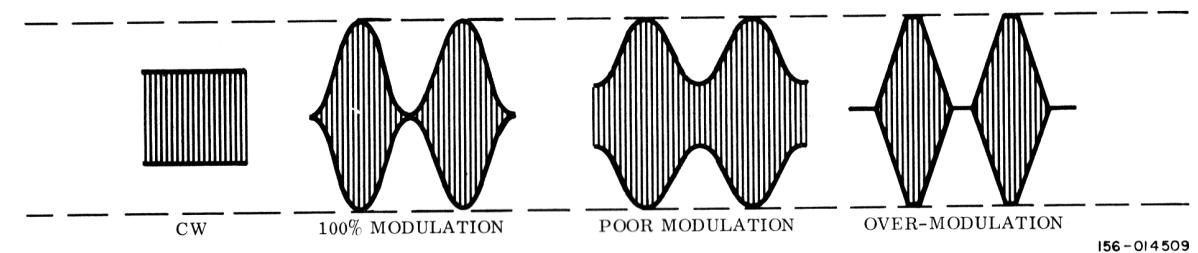

Figure 6-4. Modulation Waveforms.