

This manual is not for sale.

It is free on the internet.

Other people scanned this material for free for the use of hobbyisys with the condition that it is not for sale.

It is unethical to sell it.

It may not be sold or bundled in any way with any product or service or access right for sale or lease.

If you paid for it, take your money back.

This page intentionally left blank

**VIDEO MODULE  
MODEL VR-4  
FOR USE WITH  
UNIVERSAL SPECTRUM ANALYZER**

**SINGER**  
INSTRUMENTATION

# INSTRUCTION MANUAL

**VIDEO MODULE  
MODEL VR-4  
FOR USE WITH  
UNIVERSAL SPECTRUM ANALYZER  
MODELS TA-2 AND RTA-5**

**Serial No. \_\_\_\_\_**

**Manual No. 110-5030**

NOTE

THIS INSTRUCTION MANUAL IS TO BE  
USED ON EQUIPMENTS WITH SERIAL  
NO. U15625 AND ABOVE ONLY

**SINGER**  
INSTRUMENTATION

THE SINGER COMPANY • INSTRUMENTATION DIVISION

**Creative Products for Test, Measurement, Analysis, Calibration**



# TABLE OF CONTENTS

Paragraph		Page
<b>SECTION I — INTRODUCTION</b>		
1-1	Scope of Manual . . . . .	1-1
1-5	Purpose and Use of Equipment . . . . .	1-1
1-8	General Description . . . . .	1-1
1-16	Specifications . . . . .	1-2
1-18	Transistor, Diode, and Crystal Complement . . . . .	1-2
<b>SECTION II — OPERATION</b>		
2-1	General . . . . .	2-1
2-3	Installation . . . . .	2-1
2-5	Preliminary Operating Procedure . . . . .	2-1
2-7	Operating and CRT Interpretation . . . . .	2-7
2-9	General Considerations . . . . .	2-8
2-10	Input Signal Classification . . . . .	2-8
2-13	Maximum Input Voltages . . . . .	2-8
2-15	Special Considerations . . . . .	2-8
2-16	Optimum Resolution of Signals Closely Spaced in Frequency . . . . .	2-8
2-20	Noise Analysis . . . . .	2-10
2-31	Interpreting CRT Displays . . . . .	2-10
2-42	Amplitude Measurement of Discrete Signals . . . . .	2-15
2-43	Frequency Measurement of Discrete Signals . . . . .	2-16
2-44	Operating Procedures . . . . .	2-16
<b>SECTION III — THEORY OF OPERATION</b>		
3-1	General . . . . .	3-1
3-3	Simplified Block Diagram Discussion . . . . .	3-1
3-8	Detailed Theory of Operation . . . . .	3-2
3-9	General . . . . .	3-2
3-10	Input Attenuator Assembly A9 . . . . .	3-2
3-11	First Mixer Assembly A8 . . . . .	3-2
3-12	32.328 MHz I-F Ampl/2nd Mixer/29.538 MHz Osc Assembly A3 . . . . .	3-7
3-13	2.7 MHz Crystal Filter Assembly A4 . . . . .	3-7
3-14	I-F Attenuator . . . . .	3-7
3-15	2.7 I-F Ampl/Detector Assembly A2 and Log-Lin Assembly A6 . . . . .	3-7
3-17	DC Control Assembly A1 . . . . .	3-7
3-21	Narrow-band Local Oscillator Assembly A7 . . . . .	3-10
3-22	Multivibrator/Marker Assembly A5 . . . . .	3-10
3-24	Power Distribution . . . . .	3-11
<b>SECTION IV — MAINTENANCE</b>		
4-1	General . . . . .	4-1
4-5	Test Equipment Required . . . . .	4-1
4-7	Preliminary Inspection . . . . .	4-1
4-8	Preliminary Inspection Routines . . . . .	4-1
4-9	Component Location . . . . .	4-1
4-10	Minimum Performance Standards Checks . . . . .	4-1
4-13	Touchup Alignment . . . . .	4-8

## TABLE OF CONTENTS (Cont'd)

Paragraph		Page
<b>SECTION IV — MAINTENANCE (Cont'd)</b>		
4-15	Alignment Procedures . . . . .	4-23
4-18	Preliminary Control Settings . . . . .	4-23
4-19	Horizontal and Vertical Sweep Position Adjustment . . . . .	4-23
4-20	Marker Frequency Adjustment . . . . .	4-24
4-21	Preliminary Oscillator and I-F Alignment . . . . .	4-24
4-22	2.7 MHz Crystal Filter Adjustment . . . . .	4-25
4-23	Final Oscillator and I-F Alignment . . . . .	4-25
4-24	26.838 MHz Trap Adjustment . . . . .	4-25
4-25	Phase Splitter, Balance, and Harmonic Distortion Adjustments . . . . .	4-26
4-26	Sweep Rate Adjustment . . . . .	4-26
4-27	Amplitude Adjustment . . . . .	4-26
4-28	Shaping Circuit Adjustment . . . . .	4-27
4-29	Systematic Trouble Localization . . . . .	4-28
4-32	Typical Voltage Measurements . . . . .	4-28

## SECTION V — SCHEMATIC DIAGRAMS

### SECTION VI — PARTS LIST

6-1	Introduction . . . . .	6-1
6-3	Ordering Information . . . . .	6-1
6-5	How to Use the Parts List . . . . .	6-1
6-7	Ref Symbol Column . . . . .	6-1
6-8	Description Column . . . . .	6-1
6-9	Manufacturer's Part Number Column . . . . .	6-1
6-10	Mfr's Code Column . . . . .	6-1
6-11	Maint Qty Column . . . . .	6-1

## LIST OF ILLUSTRATIONS

Figure		Page
1-1	Video Module Model VR-4 . . . . .	iv
1-2	Typical Resolution Versus Sweep Width . . . . .	1-3
1-3	Typical Minimum Frequency Separation Required to Measure Amplitude Ratios (Skirt Selectivity) . . . . .	1-3
2-1	Video Module VR-4 Controls, Indicators, and Connector . . . . .	2-2
2-2	Typical CRT Displays During Mixer Balancing . . . . .	2-7
2-3	Peaking of Zero Pip in Search/Lock Mode During Mixer Balancing . . . . .	2-7
2-4	Typical CRT Displays of Various Noise Signals . . . . .	2-11
2-5	Typical CRT Displays of Various Discrete Signals . . . . .	2-12
2-6	Determining Pulse Width and PRF of a Pulsed RF Signal . . . . .	2-15
2-7	Signal in Search/Lock Mode . . . . .	2-18
3-1	Video Module Model VR-4, Simplified Block Diagram . . . . .	3-3
3-2	Video Module Model VR-4, Detailed Block Diagram . . . . .	3-5
3-3	Sawtooth Generator, Simplified Schematic Diagram . . . . .	3-8
4-1	Extender Board . . . . .	4-2
4-2	Video Module Model VR-4, Bottom View . . . . .	4-4
4-3	Printed-circuit Module Location . . . . .	4-5
4-4	DC Control Module A1, Adjustment Locations . . . . .	4-6
4-5	2.7 MHz I-F Ampl/Detector Module A2, Adjustment Locations . . . . .	4-6
4-6	32.238 MHz I-F Ampl/2nd Mixer/29.538 MHz Osc Module A3, Adjustment Locations . . . . .	4-7
4-7	2.7 MHz Crystal Filter Module A4, Adjustment Locations . . . . .	4-7
4-8	Multivibrator/Marker Module A5, Adjustment Locations . . . . .	4-8

## LIST OF ILLUSTRATIONS (Cont'd)

Figure		Page
4-9	Log-Lin Module A6 and First Mixer Module A8, Adjustment Locations . . . . .	4-9
4-10	Minimum Performance Standards, Equipment Setup . . . . .	4-22
5-1	Video Module Model VR-4, Schematic of Interconnection . . . . .	5-3
5-2	Log/Lin Assembly A6, Narrow-Band Local Oscillator Assembly A7, and First Mixer Assembly A8, Schematic Diagram . . . . .	5-5
5-3	32.238 MHz I-f Amplifier/2nd Mixer/29.538 MHz Oscillator Assembly A3, Schematic Diagram . . . . .	5-7
5-4	2.7 MHz Crystal Filter Assembly A4, Schematic Diagram . . . . .	5-9
5-5	I-f Amplifier Detector Assembly A2, Schematic Diagram . . . . .	5-11
5-6	DC Control Assembly A1, Schematic Diagram . . . . .	5-13
5-7	Multivibrator/Marker Assembly A5, Schematic Diagram . . . . .	5-15
6-1	Parts List Sample . . . . .	6-2

## LIST OF TABLES

Table		Page
1-1	Specifications . . . . .	1-2
1-2	Transistor, Diode, and Crystal Complement . . . . .	1-4
2-1	Operating Controls, Indicators and Connectors . . . . .	2-2
2-2	Input Voltages (RMS) Required for Full-Scale Deflection . . . . .	2-9
4-1	Test Equipment Required . . . . .	4-3
4-2	Preliminary Inspection Routine . . . . .	4-3
4-3	Minimum Performance Standards Checks . . . . .	4-10
4-4	Shaping Circuit Adjustment Tabulation . . . . .	4-28
4-5	Systematic Trouble Localization . . . . .	4-28
4-6	Voltage Measurements . . . . .	4-31
6-1	Manufacturer's Code . . . . .	6-2
6-2	Parts List . . . . .	6-5

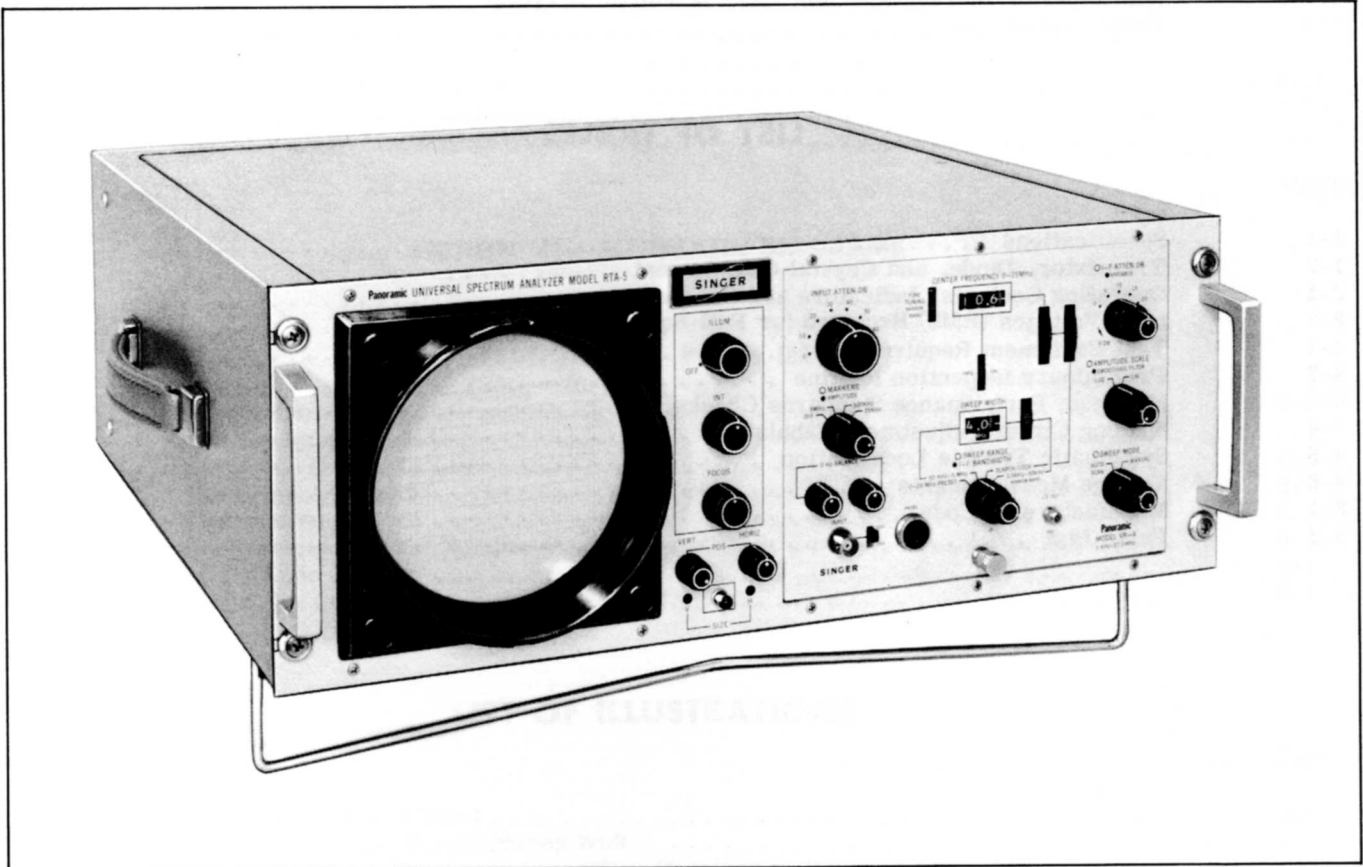

Figure 1-1. Video Module Model VR-4

## SECTION I

### INTRODUCTION

#### 1-1. SCOPE OF MANUAL.

1-2. This instruction manual provides operating and maintenance instructions on PANORAMIC\* Video Module Model VR-4, figure 1-1, manufactured by The Singer Company, Metrics Division. The VR-4 module is used in conjunction with either Main Frame Model MF-2 or MF-5 to form either PANORAMIC Universal Spectrum Analyzer Model TA-2 (portable) or RTA-5 (rack or bench mounted), respectively.

1-3. Basically, this manual describes only the VR-4 Video Module since the main frames described are discussed in separate instruction manuals. However, some main frame functions are described in this manual, to clarify the description of the VR-4 Module.

1-4. The information contained in this manual refers only to the standard versions of Video Module Model VR-4 and is current only to the date of publication. Differences in equipment components, specifications, and performance resulting from The Singer Company's continuous product improvement program or individual customer design and application requirements are described in addendum sheets.

#### 1-5. PURPOSE AND USE OF EQUIPMENT.

1-6. Video Module Model VR-4 in conjunction with a main frame (Model MF-2 or MF-5) provides a reliable means of analyzing and monitoring complex discrete and/or random signals from 0-27.5 MHz. The VR-4 and associated main frame form a spectrum analyzer which plots level versus frequencies within its scanned band. The VR-4 spectrum analyzer configuration is intended primarily for video applications. Depending upon the main frame selected for use with the VR-4, portable (MF-2) or rack or bench mounted (MF-5), the spectrum analyzer may be used in field or laboratory applications. Applications include:

- a. Spectrum monitoring of communication channels.
- b. Studies of noise spectra.
- c. Monitoring of RFI and ECM spectra.
- d. Analysis of telemetry subcarriers.
- e. Dynamic performance analysis of oscillators, generators, transmitters, etc., operating in the video range.

\*A Trademark of THE SINGER COMPANY

- f. Direct reading of power points and nulls.
- g. Analyzing pulse signals.
- h. Studies of malfunction in microwave equipment (e.g. spurious signals, instability, microphonics, etc.)
- i. Examination of signals for frequency drift, incidental FM, and squegging.

1-7. The PANORAMIC Universal Spectrum Analyzer Model RTA-5 provides the same capabilities as the portable TA-2 in any environment where battery operation is not required. These spectrum analyzers provide a calibrated, graphic representation of the spectral contents in the video frequency range for research or production measurements. Once the norms for an application are established, the operator can rapidly identify and correlate CRT screen deflections. Abnormalities are readily discernible from which a go/no-go or quantitative determination may be made.

#### 1-8. GENERAL DESCRIPTION.

1-9. The Model VR-4 is a transistorized, plug-in, broadband swept analyzer module associated with PANORAMIC Universal Spectrum Analyzer Models TA-2 and RTA-5 for the 0 MHz - 27.5 MHz frequency range. This module performs the signal processing, including detection. It also generates the sawtooth waveform for the horizontal sweep deflection amplifiers in the associated main frame.

1-10. The module has three sweep ranges that can be selected by means of a SWEEP RANGE switch: 0-25 MHz PRESET, 50 KHz - 5 MHz, and 0.5 kHz - 50 KHz NARROW BAND. In the first range, the sweep width is fixed at 25 MHz. In the other ranges, the sweep width is continuously variable and can be set at any value in the range. The sweep width is linear in all three ranges.

1-11. The SWEEP WIDTH and CENTER FREQUENCY controls are calibrated precisely on front-panel digital dials. The SWEEP WIDTH dial is calibrated in megahertz in the first two sweep ranges and in kilohertz in the last sweep range to provide maximum accuracy; it is inoperative in the 0-25 MHz PRESET mode. The range of the CENTER FREQUENCY dial corresponds to approximately 5 feet of length so that precise adjustment and ease of operation is obtained. Thus, the width and center frequency of the CRT display can be ascertained readily.

1-12. A crystal-controlled, internal marker oscillator provides markers at 5-MHz intervals

Section I  
Introduction

throughout the band of the VR-4. The output of the marker oscillator is also divided digitally to provide 500 kHz and 25 kHz markers. A front-panel MARKERS switch permits selection of any or none (OFF position) of the markers. An associated MARKERS AMPLITUDE control permits the adjustment of the markers amplitude. All markers are accurate to within  $\pm .02$  percent of nominal value. A zero-frequency pip is also provided as an additional calibration reference.

1-13. The VR-4 provides either a linearly or logarithmically scaled dc output. Signal sensitivity is less than 30 microvolts for full scale linear output and less than 300 microvolts for the logarithmic output. Calibrated r-f (INPUT ATTEN DB control) and i-f (I-F ATTEN DB control) attenuators for adjusting the deflection produced by strong signals are provided; and uncalibrated continuously variable i-f attenuator is also provided. Residual unwanted responses, including those due to hum and harmonic and intermodulation distortion, are suppressed at least 50 dB.

1-14. The VR-4 has three sweep modes: preset, variable, and manual. These are selected and

controlled by a front-panel SWEEP MODE switch and a Sweep Rate (VAR) control, respectively as described in section III.

1-15. The i-f section of the VR-4 contains two manually-controlled, variable-bandwidth crystal filters. These filters provide high selectivity so that the resolution (the ability to separate individual frequency components) can be optimized using the front-panel I-F BANDWIDTH control.

**1-16. SPECIFICATIONS.**

1-17. Table 1-1 lists the specifications and physical characteristics of the VR-4 module.

**1-18. TRANSISTOR, DIODE, AND CRYSTAL COMPLEMENT.**

1-19. The transistor, diode, and crystal complement of the VR-4 module is given in table 1-2.

TABLE 1-1. SPECIFICATIONS

Frequency range (includes sweep):	0 - 27.5 MHz
Center frequency range:	0 - 25 MHz
Center frequency accuracy:	$\pm 5\%$ , $\pm 10$ kHz
Sweep Width	Three ranges: <ul style="list-style-type: none"> <li>a. 0 - 25 MHz PRESET - accurate to <math>\pm 5\%</math> at all points</li> <li>b. 50 kHz - 5 MHz, continuously variable - accurate to 10%, <math>\pm 20</math> kHz of dial reading</li> <li>c. 1.0 kHz - 50 kHz NARROW BAND, continuously variable - accurate to <math>\pm 10\%</math>, <math>\pm 200</math> Hz of dial reading</li> </ul>
Frequency scale linearity:	$\pm 5\%$ on all ranges
I-f bandwidth (Resolution):	I-f bandwidth adjustable from 200 Hz to 18 kHz (typical) at -6 dB points.  (Resolution is the frequency separation of two signals of equal amplitude, the deflections of which intersect 3 dB down from their amplitude peaks. Figure 1-2 is a resolution graph for a CRT linear horizontal scan. Figure 1-3 presents the minimum frequency separation required to measure signals of unequal amplitude.) These graphs show typical curves.

(Cont'd)



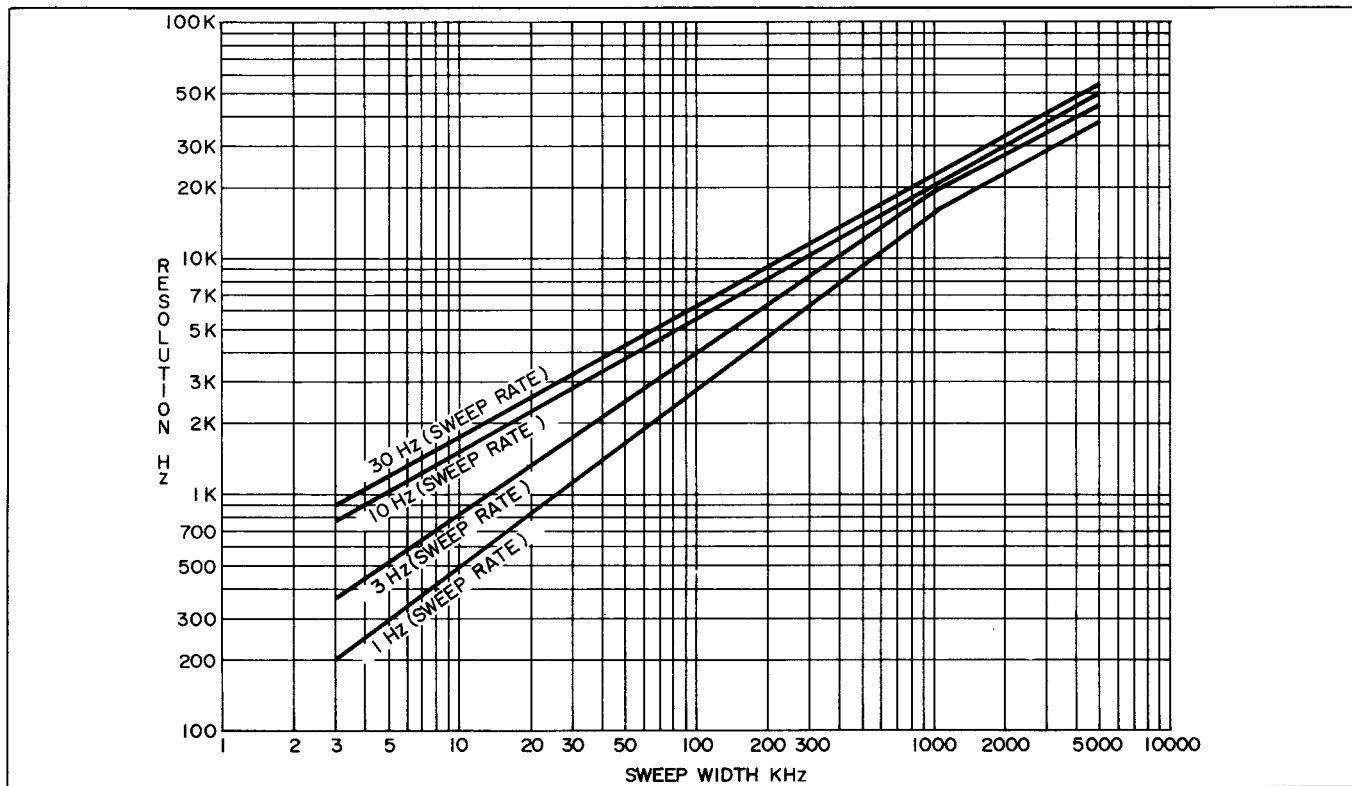

Figure 1-2. Typical Resolution Versus Sweep Width

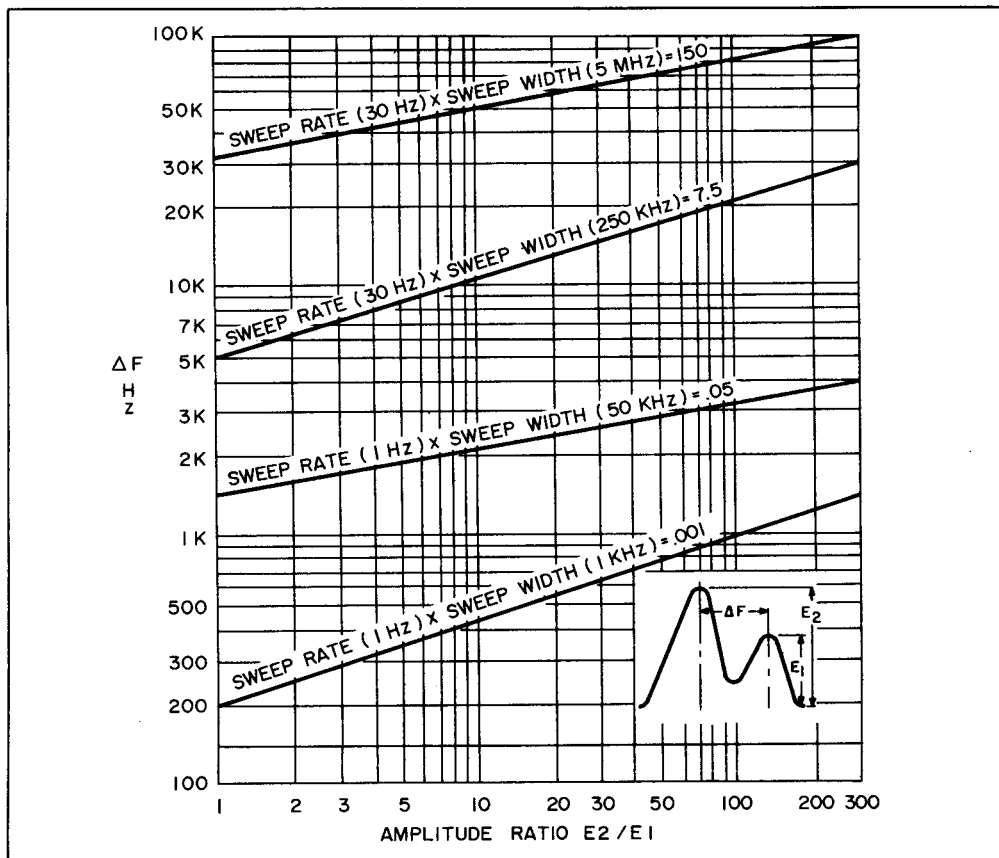

Figure 1-3. Typical Minimum Frequency Separation Required to Measure Amplitude Ratios (Skirt Selectivity)

TABLE 1-1. SPECIFICATIONS (Cont'd)

Scan rate:	Continuously adjustable, 1 to 60 Hz, preset at 1 Hz, or manually controlled
Amplitude scale:	Linear: Calibrated 1 to 10 in 10 percent increments, accuracy $\pm 3\%$ . Log: Calibrated 0 to 40 dB, in 5 dB increments; accuracy $\pm 1$ dB, from 0 to -30 dB, $\pm 2$ dB from -30 dB to -40 dB.
Sensitivity full scale:	Linear Deflection - 30 microvolts minimum. Logarithmic Deflection - 300 microvolts minimum.
Minimum detectable signal:	3 microvolts
Attenuators:	Input: 0 to 70 dB in 10 dB steps $\pm 0.05$ dB per dB I-f: 0 to 20 dB in 5 dB steps $\pm 0.2$ dB per step. Also 0 - 10 dB continuously variable (uncalibrated)
Input impedance:	50 or 75 ohms switch selectable
Frequency calibration markers:	5 MHz, 500 kHz, or 25 kHz, switch selectable - accurate to $\pm 0.02$ percent. Amplitude is continuously variable.
Residual distortion:	Harmonics, intermodulation, hum and spurious signals more than 50 dB down.
Video filter-smoothing:	Front panel variable control for smoothing of random signal inputs. Adjust time constant to a maximum of 0.05 seconds.
Frequency response:	Flat within $\pm 1$ dB from 1 kHz - 27.5 MHz.
Operating temperature range:	0 to 55 degrees centigrade
Physical Characteristics:	Weight                      Approximately 15 pounds Width                        8 inches Height                        6 inches Depth                         9.5 inches Volume                        456 cubic inches

TABLE 1-2. TRANSISTOR, DIODE, AND CRYSTAL COMPLEMENT

Reference Designation Symbol	Type	Function
Transistors		
A1Q1, A1Q2	2N3565	DC Amplifier
A1Q3	556146-652 (Singer)	Sawtooth Generator
A1Q4	2N2270	Emitter Follower

(Cont'd)

TABLE 1-2. TRANSISTOR, DIODE, AND CRYSTAL COMPLEMENT (Cont'd)

Reference Designation Symbol	Type	Function
Transistors		
A1Q5	2N3638A	Sawtooth Shaping Amplifier
A1Q6, A1Q8, A1Q10	2N3565	Emitter Follower
A1Q9	2N3638A	Emitter Follower
A1Q11	2N3565	} Complimentary DC Amplifier
A1Q12	2N3638A	
A1Q13	2N3565	
A2Q1, A2Q2, A2Q3, A2Q4	2N2188	2.7 MHz I-f Amplifier
A2Q5	2N3638A	Log Amplifier
A2Q6	2N2188	} Dual Emitter Follower
A2Q7	2N1091	
A2Q8	2N2270	Emitter Follower
A3Q1, A3Q2	2N4917	32.238 MHz I-f Amplifier
A3Q3	2N4917	2.7 MHz Mixer
A3Q4	2N3565	29.538 MHz Oscillator
A4Q1	2N3638A	2.7 MHz Crystal Filter
A4Q2	2N3638A	Emitter Follower
A4Q3, A4Q4	2N3638A	2.7 MHz I-f Amplifier
A4Q5	2N3638A	2.7 MHz Crystal Filter
A4Q6	2N3638A	Emitter Follower
A4Q7	2N3565	2.7 MHz I-f Amplifier
A4Q8	2N3638A	2.7 MHz I-f Amplifier
A4Q10	2N3638A	Emitter Follower
A5Q1, A5Q2, A5Q3, A5Q4, A5Q7, A5Q8, A5Q9, A5Q10	2N3646	Decade Divider
A5Q5, A5Q6	2N3563	5 MHz Marker Oscillator
A5Q11, A5Q12	2N2188	Amplifier
A5Q13	2N3563	Emitter Follower

(Cont'd)

TABLE 1-2. TRANSISTOR, DIODE, AND CRYSTAL COMPLEMENT (Cont'd)

Reference Designation Symbol	Type	Function
Transistors		
A5Q14, A5Q15	2N3646	Binary Divider
A5Q16	2N3563	Amplifier
A5Q17	T1M05	Amplifier
A5Q18	2N3563	Amplifier
A5Q19, A5Q20	2N706A	Wide-Band Oscillator
A7Q1	2N3563	Narrow Band Oscillator
A7Q2, A7Q3	2N3563	Amplifier
A7Q4	2N3563	Emitter Follower
A8Q1	2N3563	Phase Splitter
A8Q2	2N3563	Amplifier
A8Q3, A8Q4	2N3563	Balanced Mixer
Diodes		
A1CR1	232 (Diodes, Inc.)	Voltage Regulator
A1CR2, A1CR3, A1CR4, A1CR5	1N935	Voltage Regulator
A1CR6	2320 (Diodes, Inc.)	Voltage Regulator
A1CR7	1N935	Voltage Regulator
A1CR8, A1CR14, A1CR15	1N251	Constant Voltage Drop
A1CR9, A1CR10, A1CR11, A1CR12, A1CR13	1N270	Diode Switch
A1CR16	1N251	Constant Voltage Drop
A2CR1	1N906	Constant Voltage Drop
A2CR2, A2CR3	1N251	Full-Wave Detector
A4CR1, A4CR2, A4CR3, A4CR4	1N906	Full-Wave Detector (2)
A4CR5	1N251	Temperature Compensation
A5CR1, A5CR2, A5CR3, A5CR4, A5CR5, A5CR6, A5CR7, A5CR8	1N995	Clamp

(Cont'd)

TABLE 1-2. TRANSISTOR, DIODE, AND CRYSTAL COMPLEMENT (Cont'd)

Reference Designation Symbol	Type	Function
Diodes (Cont'd)		
A5CR9	1N906	Clamp
A5CR10, A5CR11	1N270	Clamp
A5CR12	232 (Diodes, Inc.)	Voltage Regulator
A5CR13, A5CR14	1N995	Clamp
A5CR15	V-33B	Variable Capacitor
A6CR1, A6CR2	HU-10	Shaping Diode (Logarithmic)
A6VR1	023L13	Shaping Diode (Logarithmic)
A7CR1	V-33B	Variable Capacitor
Crystals		
A3Y1	-	29.538 MHz Oscillator
A4Y1, A4Y2	-	2.7 MHz Filter
A5Y1	-	5 MHz Oscillator

## SECTION II OPERATION

### 2-1. GENERAL.

2-2. This section provides operating instructions for Video Module VR-4. Installation instructions are given for the module operating with either Spectrum Analyzer Main Frame MF-2 or MF-5. Main Frame MF-2 and Module VR-4 form the PANORAMIC Universal Spectrum Analyzer Model TA-2, which is the portable version. Main Frame MF-5 and Module VR-4 form the PANORAMIC Universal Spectrum Analyzer RTA-5, which is a rack or bench mount version. Instructions for mounting the VR-4 module in either of the two main frames are given in paragraph 2-3. The preliminary operating instructions for both the Model TA-2 and RTA-5 Spectrum Analyzers are given in paragraph 2-5. The operating instructions for both Spectrum Analyzers are given in paragraphs 2-7 through 2-44.

### 2-3. INSTALLATION.

2-4. The procedure for installing the VR-4 module into either the Model MF-2 or Model MF-5 Main Frame is as follows: (See figure 2-1.)

a. It is good practice to deactivate the main frame into which the VR-4 module is to be installed. The unit is deactivated by placing the (SCALE) ILLUMINATION - (POWER) OFF control in the OFF position.

b. On the Model MF-2 Main Frame, the 110 VAC - 220 VAC switch is located above the mating connector receptacle (J1) for the VR-4 module. On the Model MF-5 Main Frame, the 110 VAC - 220 VAC switch is located to the left of the DC 3A fuse on the rear panel of the chassis. Set the 110 VAC - 220 VAC switch to the position applicable to the ac power source to be used.

c. After turning the knurled fastening knob fully ccw, insert the VR-4 module into the main frame (MF-2 or MF-5), and firmly mount in place so that the front panel of the VR-4 module is flush with the front panel of the main frame.

d. Tighten knurled knob of securing hardware until VR-4 module is firmly in place. Pull on knob to verify that the module is securely in place.

### 2-5. PRELIMINARY OPERATING PROCEDURE.

2-6. The preliminary operating procedure provides instructions for activating and setting up the VR-4 module and associated main frame (MF-2 or MF-5).

A description of reference designations, nomenclature and function of all controls, indicators, and connectors for the VR-4 module is given in table 2-1, with corresponding identifying callouts shown in figure 2-1. Proceed as follows:

a. Set the following controls on the VR-4 module as indicated:

<u>Control</u>	<u>Position</u>
CENTER FREQUENCY 0-25 MHz potentiometer R12	00.0 on CENTER FREQUENCY dial
I-F ATTEN DB switch S5	10
I-F ATTEN DB VARIABLE potentiometer R20	Fully CCW
AMPLITUDE SCALE switch S6	LOG
SMOOTHING FILTER potentiometer R11	Fully CCW
SWEEP MODE switch S4	AUTO SCAN
Sweep rate (VAR) potentiometer R11	Fully CW
I-F BANDWIDTH potentiometer R9	MAX (Fully CW)
SWEEP RANGE switch S3	0-25 MHz PRESET
MARKERS switch S2	5 MHz

b. Connect the power cable between the 110 volt ac or 220 volt ac power source and the AC INPUT receptacle on the main frame (MF-2 main frames have the power cable permanently attached at the rear panel).

CAUTION

Be sure that the 110 VAC - 220 VAC control on the MF-5 main frame rear panel or on the main frame MF-2 interior (plug-in module recess) near connector J1 is set at the proper position for the ac power source used. On main frame MF-2, the ac line fuse should be 3/8 ampere delay type for 110 volt ac operation, and a 3/16 ampere delay type for 220 volt ac operation. On main frame MF-5, the ac line fuse should be 3/4 ampere delay type for 110 volt ac operation, and 3/8 ampere delay type for 220 volt ac operation. The DC fuses on the main frames remain unchanged at 2 amperes for the MF-2 and 3 amperes for the MF-5, regardless of ac line voltage used.



Section II  
Operation

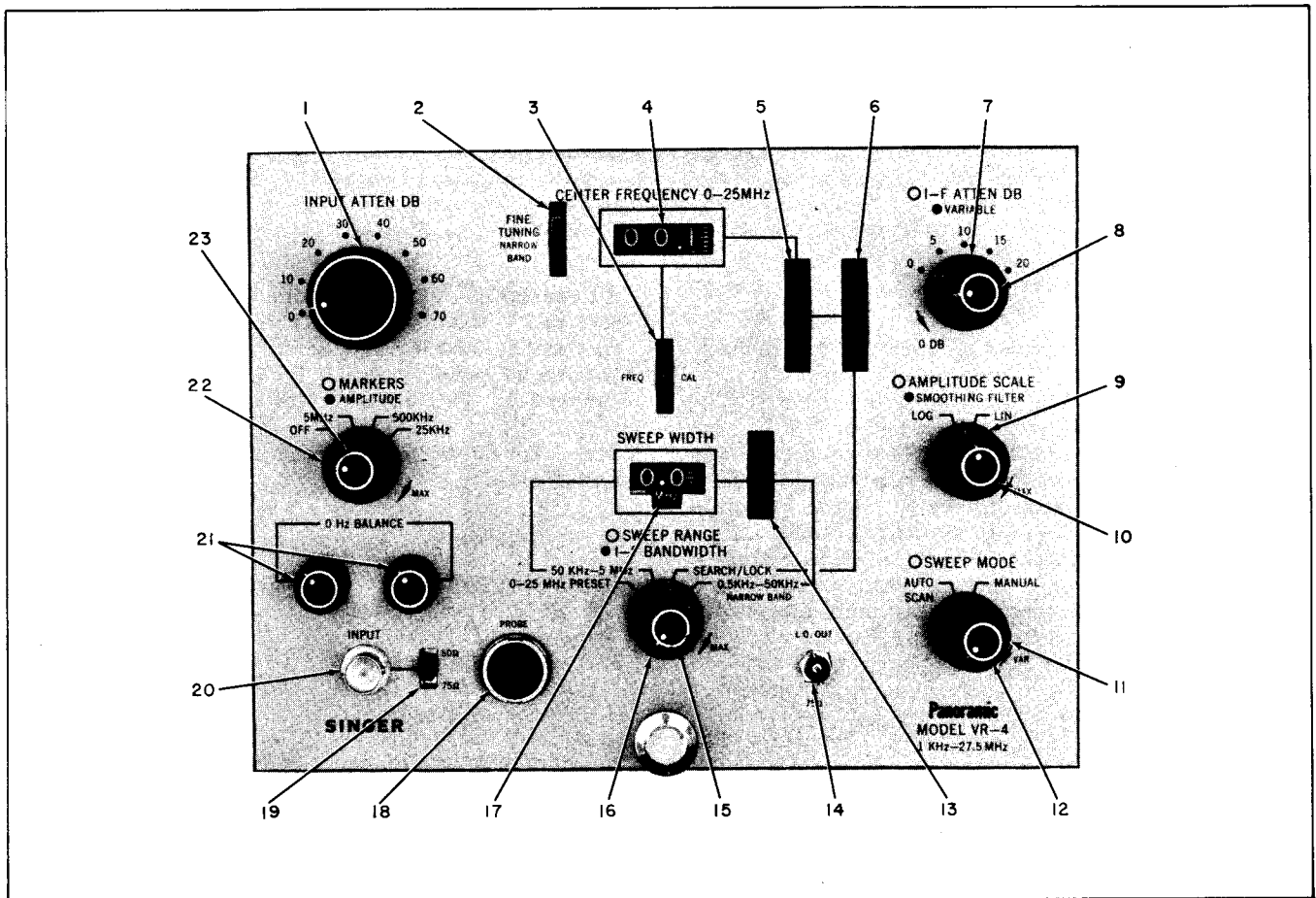

Figure 2-1. Video Module VR-4 Controls, Indicators, and Connectors.  
(See table 2-1.)

TABLE 2-1. VIDEO MODULE VR-4 OPERATING CONTROLS, INDICATORS, AND CONNECTORS

Index No. (Figure 2-1)	Reference Designation	Name	Function
1	A9S1	INPUT ATTEN DB switch	An eight-position rotary switch that inserts 0 to 70 dB of attenuation (in 10-dB steps) in the signal-input circuitry.
2	R10	FINE TUNING NARROW BAND control	A potentiometer that provides a fine adjustment of the center frequency on the CRT screen when SWEEP RANGE switch is in NARROW BAND position.
3	R13	FREQ CAL control	A potentiometer that is used to calibrate the graticule to the CENTER FREQUENCY counter.
4	-	CENTER FREQUENCY dial	A digital counter readout that indicates center frequency of the cathode ray tube (CRT) display in the 50 KHz - 5 MHz position of SWEEP RANGE switch; this frequency can be

(Cont'd)

TABLE 2-1. VIDEO MODULE VR-4 OPERATING CONTROLS, INDICATORS, AND CONNECTORS (Cont'd)

Index No. (Figure 2-1)	Reference Designation	Name	Function
4 (Cont'd)			adjusted by CENTER FREQUENCY control and calibrated to frequency markers by FREQ CAL control. After controls have been set in SEARCH LOCK position, the dial reads center frequency in the NARROW BAND position if no subsequent retuning (FINE TUNING) occurs. The readout should be disregarded in the 0 - 25 MHz PRESET position; the center frequency is fixed at approximately 12.5 MHz in this switch position.
5	R12	CENTER FREQUENCY control	A potentiometer that tunes the center frequency of the wide-band local oscillator in the 50 KHz - 5 MHz sweep range.
6	A7L2	SEARCH LOCK control	An adjustable inductance (Inductuner) that coarse-tunes the narrow-band local oscillator to obtain zero-beat indication in SEARCH LOCK.
7	S5	I-F ATTEN DB switch (outer control)	A five-position rotary switch that inserts 0 to 20 dB of attenuation (in 5-dB steps) in i-f circuitry.
8	R20	I-F ATTEN DB VARIABLE control (inner control)	A potentiometer that inserts 0 to 10 dB of attenuation (continuous, uncalibrated) in i-f circuitry.
9	S6	AMPLITUDE SCALE switch (outer control)	A two-position rotary switch that selects either LIN (linear) or LOG (logarithmic) voltage-amplitude scale of CRT display.
10	R14	SMOOTHING FILTER control (inner control)	A potentiometer that provides a continuous, uncalibrated adjustment of a video filter; smooths video output until a single-line presentation (representing the average amplitude of a noise spectrum envelope) is displayed on the CRT screen.
11	S4	SWEEP MODE switch (outer control)	A two-position rotary switch that selects either AUTO SCAN (continuous sweep) or MANUAL (controlled CRT spot position). The SWEEP MODE controls have no effect on the automatic 1-Hz sweep rate in the 0-25 MHz PRESET position or the 60-Hz sweep rate in the SEARCH LOCK position.
12	R11	Sweep Rate (VAR) control (inner control)	A potentiometer that provides continuous, uncalibrated control of the AUTO SCAN sweep rate between 1 and 60 Hz when SWEEP MODE switch is 50 KHz - 5 MHz or

(Cont'd)

Section II  
Operation

TABLE 2-1. VIDEO MODULE VR-4 OPERATING CONTROLS, INDICATORS, AND CONNECTORS (Cont'd)

Index No. (Figure 2-1)	Reference Designation	Name	Function
12 (Cont'd)			0.5 KHz - 50 KHz NARROW BAND position, and continuously adjusts the MANUAL CRT spot to any desired horizontal (frequency) position on the screen in these switch positions.
13	R8	SWEEP WIDTH control	A potentiometer that adjusts the width of frequency segment of spectrum to be displayed on CRT screen in the 50 KHz - 5 MHz and 0.5 KHz - 50 KHz NARROW BAND positions of the SWEEP RANGE switch; provides any sweep width from 50 KHz to 5 MHz or 500 Hz to 50 KHz depending upon mode selected by SWEEP RANGE switch.
14	J7	L. O. OUT jack	A BNC connector (75-ohm impedance) that supplies the swept local oscillator signal as an output to the PANORAMIC Companion Sweep Generator, Model G-6V. Output frequency is 32.238 MHz (i-f frequency) above the input frequency.
15	R9	I-F BANDWIDTH control (inner control)	A potentiometer that adjusts bandwidth of i-f stages and thereby controls resolution on CRT in 50 KHz - 5 MHz and 0.5 KHz - 50 KHz NARROW BAND positions of SWEEP RANGE switch. This control has no effect in other positions; i-f bandwidth is at maximum for these other positions.
16	S3	SWEEP RANGE switch (outer control)	<p>A four position rotary switch that enables inspection of the frequency spectrum in successively smaller windows:</p> <p>0-25 MHz PRESET position:</p> <p>selects a preset linear frequency display of the entire 0 to 25 MHz frequency range with a fixed scan rate of 1 Hz.</p> <p>50 KHz - 5 MHz position:</p> <p>selects a linear frequency display in which the center frequency, sweep width, and scan rate are adjustable. (The sweep width is adjustable from 50 KHz to 5 MHz.)</p>

(Cont'd)

TABLE 2-1. VIDEO MODULE VR-4 OPERATING CONTROLS, INDICATORS, AND CONNECTORS (Cont'd)

Index No. (Figure 2-1)	Reference Designation	Name	Function
16 (Cont'd)			<p><b>SEARCH LOCK position:</b></p> <p>selects a linear frequency display in which the frequencies of the wide-band and narrow-band local oscillators are compared. This mode is used to lock the narrow-band local oscillator to the same center frequency as the wide-band local oscillator before switching to the NARROW BAND position; this is accomplished by adjusting the SEARCH LOCK and FINE TUNING controls for an indication of zero beat.</p> <p><b>0.5 KHz - 50 KHz NARROW BAND position:</b></p> <p>selects a linear frequency display in which the center frequency, sweep width, and scan rate are adjustable. The sweep width is adjustable from 500 Hz to 50 KHz.</p>
17		SWEEP WIDTH dial	A digital counter readout that indicates width of frequency segment selected by SWEEP WIDTH control; indicates sweep width in MHz when SWEEP RANGE switch is positioned to 50 KHz - 5 MHz, and in KHz when the switch is positioned to 0.5 KHz - 50 KHz NARROW BAND.
18	J8	PROBE jack	A special connector that accommodates use of the optionally supplied high-impedance probe for analyzing sources of high impedance.
19	S1	INPUT switch	A two-position slide switch that sets the input impedance of the VR-4 module to 50 or 75 ohms.
20	J6	INPUT jack	A BNC connector that connects input to VR-4 module.
21	R2, R3	0 Hz BALANCE controls	Two potentiometers that suppress local oscillator leakage through the balanced mixer at zero input frequency.
22	S2	MARKERS switch (outer control)	<p>Four-position rotary switch that selects the frequency markers that appear on the CRT:</p> <p><b>OFF position:</b> removes all markers.</p>

(Cont'd)

Section II  
Operation

TABLE 2-1. VIDEO MODULE VR-4 OPERATING CONTROLS, INDICATORS, AND CONNECTORS (Cont'd)

Index No. (Figure 2-1)	Reference Designation	Name	Function
22 (Cont'd)			<p>5 MHz position: markers appear at 5-MHz intervals. Other markers are off.</p> <p>500 KHz position: markers appear at 500-KHz intervals with those at 5-MHz intervals larger than intervening ones.</p> <p>25 KHz position: markers appear at 25-KHz intervals with 500-KHz markers larger and 5-MHz markers largest.</p>
23	R7	MARKERS AMPLITUDE control (inner control)	A potentiometer that adjusts amplitude of crystal-controlled internally generated calibration markers.

c. Turn the (SCALE) ILLUMINATION - (POWER) OFF control on the main frame clockwise and adjust graticule scale illumination to a comfortable level.

d. Adjust BRIGHTNESS (MF-5) or INT (MF-2) control for discernable trace after adjusting VERT (POS) control to bring trace into view if necessary.

e. Adjust FOCUS control for a clean, sharp trace.

f. If necessary, adjust HORIZ (POS) control so that the trace has a nominally equal "spillover" beyond the left and right graticule scale margins.

g. If necessary, adjust VERT (POS) control so that the trace coincides with the horizontal division at the bottom of the graticule scale.

h. Adjust HORIZ (POS) control so that the zero pip is located at the left margin of the vertical divisions and the 5 MHz markers pips are aligned with their respective vertical divisions (i. e., every other one on the graticule scale).

i. Set MARKERS switch to OFF position.

**Note**

If the VR-4 module being used was originally calibrated for another main frame and step i does not satisfactorily adjust the zero and marker pips, a slight readjustment of the H (SIZE) control on the main frame can be used. On the MF-5 (RTA-5) main frame, the horizontal size control is a screwdriver-adjust potentiometer accessible through a front-panel hole located just below the H POS potentiometer. See figure 2-5 of main frame manual for location of MF-5 horizontal size adjustment. On the MF-2 (TA-2) main frame, the

horizontal size control is located on the right side of the cabinet (facing front panel), accessible through the lower of two holes covered by a chassis plug. See figure 4-1 of main frame manual for location of MF-2 horizontal size adjustment. Alternately adjust HORIZ (POS) and H (SIZE) controls on main frame to achieve satisfactory adjustment.

j. Set SWEEP RANGE switch to 50kHz-5MHz position.

k. Set SWEEP WIDTH dial to 5MHz using adjacent thumb-wheel control.

l. Using FREQ CAL thumb-wheel control, adjust pip so that it is coincident with the CF vertical division of graticule, as shown in figure 2-2A.

m. Set SWEEP WIDTH dial to minimum.

n. Using FREQ CAL thumb-wheel control, adjust pip to coincide with CF vertical division of graticule.

o. Set SWEEP WIDTH dial to 2 MHz using adjacent thumb-wheel control, and observe pip on screen. Pip should remain centered on CF vertical division. If pip does not remain centered, readjust HORIZ POS control.

p. Alternately adjust each OHZ BALANCE potentiometer for minimum obtainable pip amplitude as shown in figure 2-2b.

q. Set SWEEP RANGE switch to SEARCH/LOCK position.

r. Adjust large, red thumb-wheel control adjacent to CENTER FREQUENCY 0-25 MHz dial control for waveform shown in figure 2-3, at maximum amplitude.

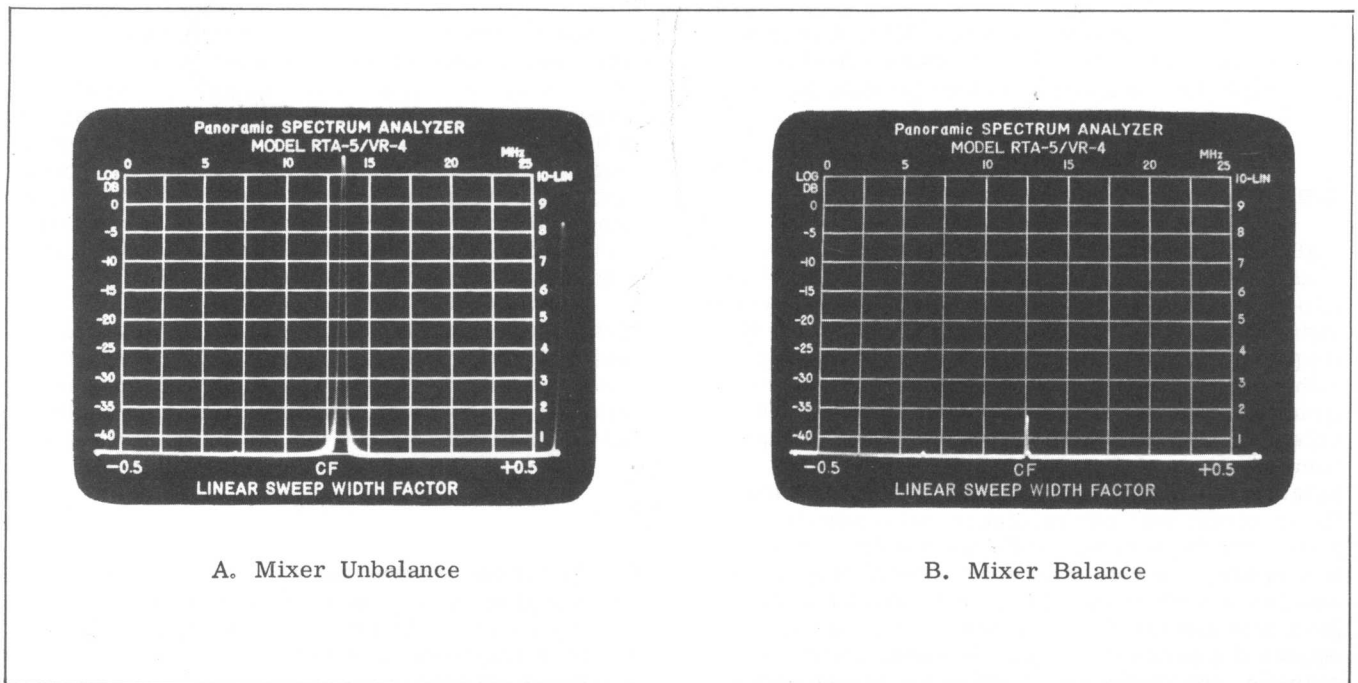

Figure 2-2. Typical CRT Displays During Mixer Balancing.

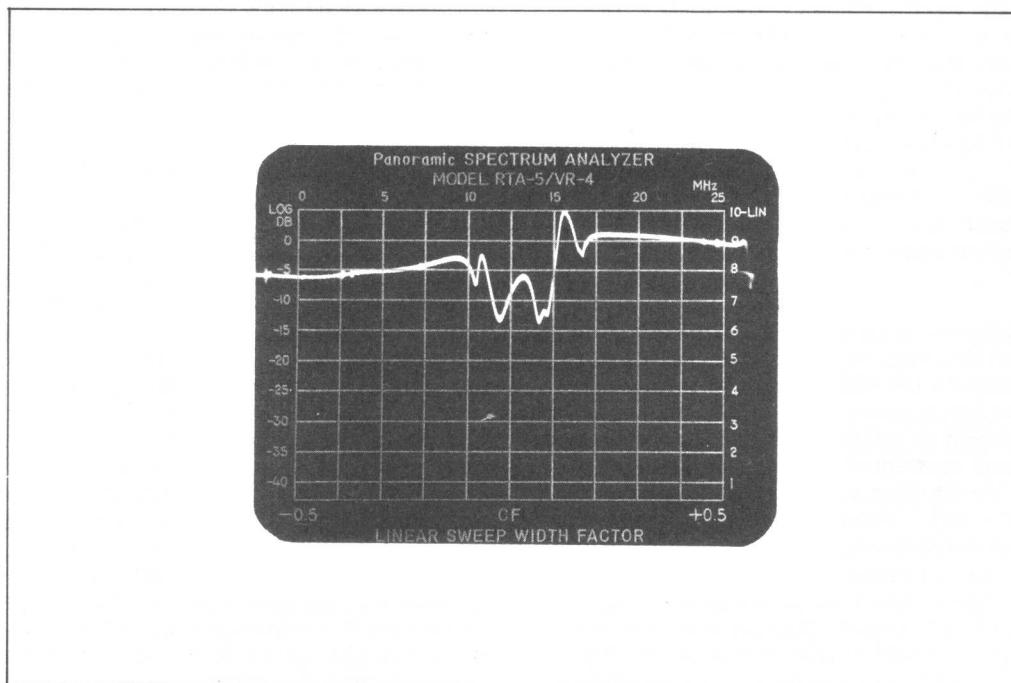

Figure 2-3. Peaking of Zero Pip in Search/Lock Mode During Mixer Balancing.

s. Set SWEEP RANGE switch to 0.5kHz - 50kHz NARROW BAND position.

t. If necessary, adjust FINE TUNING NARROW BAND thumb-wheel control to center the waveform.

u. Alternately adjust each 0Hz BALANCE potentiometer for minimum obtainable amplitude, as shown in figure 2-2B.

Preliminary operating procedure is now complete.

## 2-7. OPERATING AND CRT INTERPRETATION.

2-8. The following text and procedure provide instructions for use of the Model TA-2 and RTA-5 Spectrum Analyzers, and the way in which the displays should be interpreted. Since the usefulness of these spectrum analyzers is limited only by the ability of the operator to evaluate what is



displayed on the cathode ray tube (CRT), it is important for the user to read the text of the following paragraphs before going on to the operating procedures.

## 2-9. GENERAL CONSIDERATIONS.

2-10. **INPUT SIGNAL CLASSIFICATION.** In general, input signals to the spectrum analyzer may be divided into two types; discrete and non-discrete. Discrete signals are in the form of periodic waveforms with frequency contents which do not vary appreciably with time. The internally generated markers are typical of such a signal. Although the marker oscillator output consists of several harmonic frequency components, each frequency is discernible as a separate marker pip on the CRT screen (provided the spectrum analyzer resolution (i-f bandwidth) is proper for the frequency difference encountered). In practice, discrete signals are typical of periodic oscillation such as modulated or unmodulated signal generator and oscillator outputs, or transducer outputs if a periodic vibration is encountered; for example, constant-speed rotating machinery with a well-defined resonant vibration.

2-11. Non-discrete signals are typified by random noise in which the input frequency distribution is spread out over a band of the spectrum rather than consisting of line spectra. Random signals have a non-discrete spectrum which varies with time but usually has a definable mean (rms) level. Non-discrete signals are displayed on the spectrum analyzer as a varying envelope of amplitude at each spectrum sample. Several scans through the noise input signal usually are adequate to establish a meaningful relative amplitude-versus-frequency analysis.

2-12. Both amplitude scales are equally valid for both random and discrete signals. However, the equipment sensitivity for discrete signals is different from that for random signals. Discrete signal levels should be compared to other discrete signal levels, and random signal levels to other random signal levels when relative signal strengths are being determined. For complex signals, where both random and discrete signals are present, the spectrum analyzer correctly indicates the level of noise as well as the correct level of discrete signals. That is, neither the average random nor the discrete deflections would change if one of the other were removed from the input signal. The methods used in measuring voltage and frequency (discrete signals) as well as noise and intermodulation distortion (non-discrete signals) are described in the following operating procedures.

2-13. **MAXIMUM INPUT VOLTAGES.** For correct measurements, limits on signal voltages connected to the INPUT jack must be observed. (Refer to table 2-2.) Failure to limit the level of the indicated voltages may result in incorrect amplitude readings and indications of frequency components which are not present in the input signal. When evaluating the input level, it is necessary to measure the total

amplitude present at the input, whether related or extraneous, whether in the frequency range of the equipment, or outside of the equipment frequency range. The input amplitude should be measured with a broadband, fast-responding, peak-level indicator such as an oscilloscope. If the presence of signals not related to the signals of interest are of sufficient amplitude to overload the equipment, it is advisable to use appropriate filters to eliminate the unrelated signals.

2-14. In the case of noise analysis, unless it is definitely known that the level of signal present above the spectrum of interest is negligible, it is good practice to use a low-pass or band-pass filter to attenuate signals outside the spectrum of interest.

### Note

Amplitude overloading of the input is determined by the instantaneous peak voltage of the input signal. However, in cases where the peak amplitudes are no greater than 1.4 times the rms amplitude, a broadband rms voltmeter may be used instead of an oscilloscope, if more convenient. Even if large amplitude bursts do occur, if they are of very short time duration, they may be ignored. They will cause spurious response for a very brief period of time and thus will not appear on the CRT for any significant length of time.

## 2-15 SPECIAL CONSIDERATIONS

2-16. **OPTIMUM RESOLUTION OF SIGNALS CLOSELY SPACED IN FREQUENCY.** At full sweep width, test signals having a small frequency difference tend to have their corresponding deflections merge into and mask each other. The ability of the equipment to separate individual signals depends upon two factors: the scanning velocity (product of sweep rate and sweep width) and the bandwidth of the intermediate frequency (i-f) section of the analyzer. For any given scanning velocity, there is a corresponding i-f bandwidth for optimum resolution. The scanning velocity is reduced by increasing the sweep period (reducing the sweep rate) and decreasing the spectrum width scanned within a given time (reducing the sweep width). Reducing the scanning velocity improves the resolution (the ability of the equipment to separate closely spaced frequency components). If a signal of small amplitude is close in frequency to a signal of large amplitude, the pip representing the small amplitude signal will be influenced by the large amplitude signal (the amplitude-versus-frequency response of the i-f section being bell-shaped). As the signals are separated in frequency, the error becomes less.

2-17. The I-F BANDWIDTH control is used to adjust the i-f section bandwidth. Counterclockwise rotation of this control narrows the bandwidth. As this control is adjusted, there may be some change in the sensitivity of the equipment. Narrowing the

TABLE 2-2. INPUT VOLTAGES (RMS) REQUIRED FOR FULL-SCALE DEFLECTION

Total Attenuation (dB)	Full Scale Input Voltage (Minimum Full Scale Sensitivity)*	
	LIN scale	LOG scale
0	30.0 uv	300 uv
5	53.3 uv	533 uv
10	94.9 uv	949 uv
15	169 uv	1.69 mv
20	300 uv	3.00 mv
25	533 uv	5.33 mv
30	949 uv	9.49 mv
35	1.69 mv	16.9 mv
40	3.00 mv	30.0 mv
45	5.33 mv	53.3 mv
50	9.49 mv	94.9 mv
55	16.9 mv	169 mv
60	30.0 mv	300 mv
65	53.3 mv	533 mv
70	94.9 mv	949 mv
75	169 mv	1.69 v
80	300 mv	3.00 v

\*Full scale deflection sensitivity typically better than voltages listed.

i-f bandwidth improves resolution until a point of optimum resolution is reached. Further narrowing of the i-f bandwidth decreases resolution beyond this point, and causes a severe reduction of amplitude.

2-18. One way to obtain better resolution is to decrease the sweep speed. The choice of appropriate sweep speed is determined by the nature of the signals being studied. For example, when the test signals are sporadic, it is desirable to operate at high sweep speeds to increase the probability of intercepting the signal. When examining pulse spectra, increasing the sweep speed will reduce the number of pulse lines per scan providing the PRF is less than the i-f bandwidth. (When the PRF is greater than the i-f bandwidth, the number of lines is constant, regardless of sweep rate.)

2-19. Figure 1-2 is a graph that illustrates the relationship between sweep width, resolution, and sweep rate. The graph can be used to determine the best possible resolution for any given combination of sweep width and sweep rate. The figures given in the graph apply only within the limits specified for sweep width, sweep rates and resolution listed in specifications of Section I. To increase the resolution capabilities by reducing sweep

width, narrowing the i-f bandwidth, and increasing scanning time, the following procedures are used:

- a. Set the I-F BANDWIDTH control completely clockwise for widest i-f bandwidth.
- b. Adjust the CENTER FREQUENCY control so that the desired band of signals is at the center of the screen.
- c. Spread the band of signals across the screen by reducing the sweep width with the SWEEP WIDTH control. Each frequency calibration mark on the screen represents a frequency separation equal to one-tenth of the reading of the SWEEP WIDTH control dial.
- d. Turn the I-F BANDWIDTH control counter-clockwise until individual signals are most clearly resolved. If the signals cannot be resolved, a slower sweep rate will be required. Exceeding optimum resolution can be recognized by a severe loss of amplitude which results from using a bandwidth too narrow for a given sweep width and sweep rate; and stretching of the left-hand side of the signal pips.

### Note

If it is necessary to observe a given bandwidth with the contained signals closely spaced, the best possible resolution is indicated by the clearest picture. A reasonably accurate measurement of relative amplitudes can be made by reading the center of the beat notes between the adjacent signals.

2-20. **NOISE ANALYSIS.** In noise analysis (noise being defined as randomly fluctuating signals), the same general techniques are used for setting the equipment for the spectrum of interest as are used for discrete signals. If the input spectrum is broadband, it is very important to monitor the input level to prevent equipment overload. The following special techniques should be noted.

2-21. In general, a fairly wide i-f bandwidth is preferred for noise analysis. This permits relatively rapid scans since a wide i-f bandwidth gives better noise envelope averaging than does a narrow i-f bandwidth. However, if the noise source is highly selective (for example, influenced by a structural resonance), an i-f bandwidth which is narrow compared to the bandwidth of the resonance is required. This permits presentation of fine detail of the noise characteristics. When a narrow i-f bandwidth is used, a low sweep rate is necessary for correct amplitude presentation.

2-22. The appropriateness of the sweep rate can be determined by changing the sweep rate slightly and noting whether or not there is any change in the envelope amplitude. (The portion of envelope having the greatest slope should be watched since the greatest change in envelope will occur here.) The sweep rate should be slow enough so that a small change in sweep rate does not result in an amplitude change. If the sweep rate is at minimum, the sweep width should be reduced and/or the i-f bandwidth increased until it is possible to make a small change in sweep rate without changing the amplitude. Once a sweep which is slow enough to provide correct results has been established, a slower sweep can be set if improved envelope averaging is required.

2-23. In noise analysis, video filtering can be used to obtain averaging of the noise spectrum envelope. It is usually desirable to rotate the **SMOOTHING FILTER** control clockwise until a single-line presentation is obtained. The video filtering should not be too great (control too far clockwise) for the setting of i-f bandwidth. This can be checked by changing the sweep rate slightly and noting whether or not there is a change in the steepest portion of the presentation.

2-24. In a general sense, the i-f bandwidth, **SMOOTHING FILTER** control setting, sweep width, and sweep rate should be such that a slight change in sweep rate does not change the slope of the steepest portion of the presentation. If this is not the case, it may be necessary to reduce the sweep

rate, sweep width, or video filtering, or to increase the i-f bandwidth.

2-25. As an alternate to envelope averaging by video filtering, photographic averaging can be used. This is simply a matter of taking a composite photograph of a number of successive scans, thereby obtaining an average presentation.

2-26. The equipment sensitivity listed in Section I is applicable only to discrete signals. If absolute noise amplitude measurements are required, a calibration of the spectrum analyzer using a known noise amplitude should be made. Such a calibration must be made at the same scanning velocity (product of sweep width and sweep rate) and i-f bandwidth used for measurement since any change in scanning velocity and/or i-f bandwidth changes the amplitude.

2-27. Typical screen presentations with different control settings and different photograph exposure times of the same noise spectrum are shown in figure 2-4. To obtain a convenient presentation amplitude, the input level and/or input attenuators have been adjusted as required.

2-28. In figure 2-4A, the i-f bandwidth is narrow. The amplitude scale is linear. Since the scale is linear, the range of amplitude variation is emphasized compared to a logarithmic scale. (See figure 2-4B.) The use of a narrow i-f bandwidth also tends to emphasize the range of amplitude variation. The narrow bandwidth increases the likelihood of the equipment response at any given point being caused by a significantly higher or lower than average noise amplitude. If the i-f bandwidth is wide, it is more likely that the equipment response will be caused by a more typical noise amplitude. The result is shown in figure 2-4D.

2-29. Figure 2-4C illustrates the use of extended photographic exposure to provide a better averaging of the noise spectra.

2-30. The use of video filtering to obtain averaging of the noise spectra is illustrated in figures 2-4E and F. With the equipment settings used for E, a slight change of sweep rate caused a significant change in the presentation, thus indicating the unsuitability of the settings. The sweep rate was reduced until no change in the presentation was noted. This is the correct response and is shown in figure 2-4F.

### 2-31. INTERPRETING CRT DISPLAYS.

2-32. With a little experience, the operator will be able to visually recognize the character of the various types of signals.

2-33. A constant carrier signal appears as a deflection of fixed height with the nature of presentation depending upon the sweep width. (See figures 2-5A and B.) Deviations of the signal from true cw will result in displays which will indicate the character of the signal as follows:

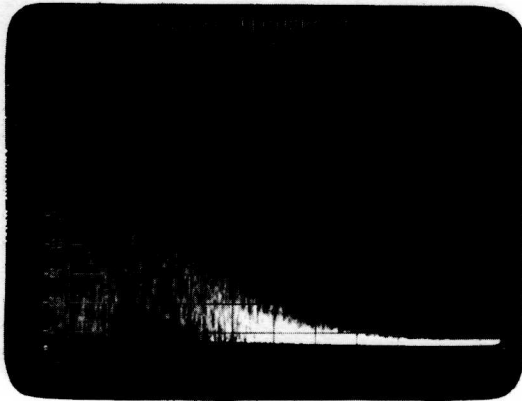

A. LIN Scale, narrow i-f bandwidth, one scan.

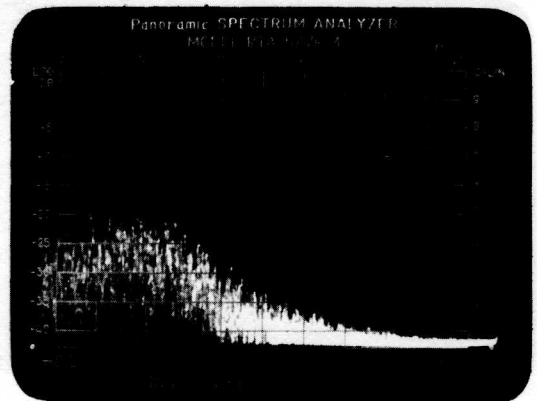

B. Same as "A" on LOG scale.

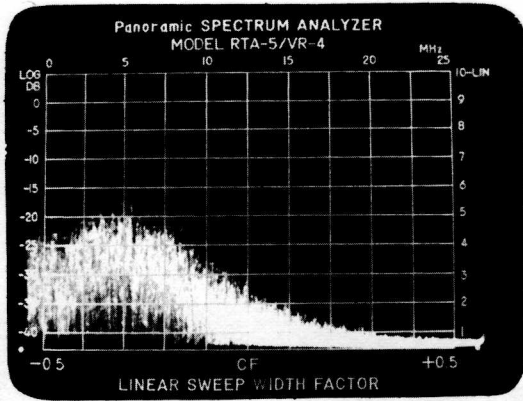

C. Same as "B" with extended photographic exposure.

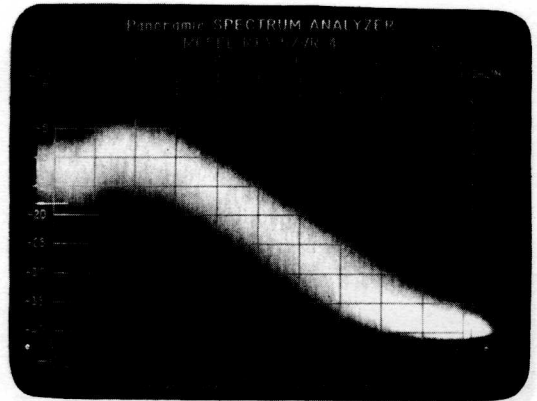

D. LOG scale, broad i-f bandwidth, one scan.

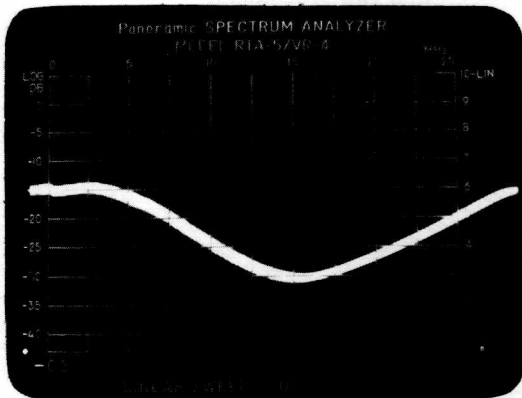

E. Same as "D" with Smoothing Filter used to obtain single line presentation. Sweep rate too fast.

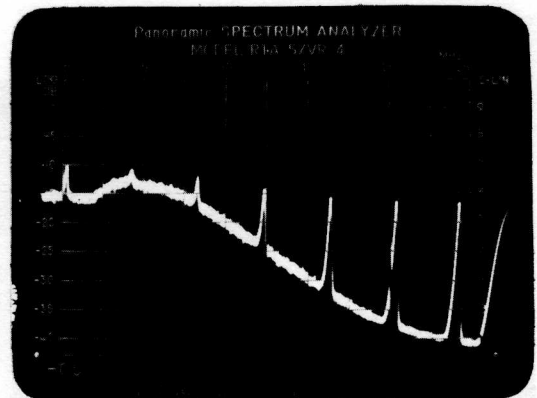

F. Same as "E" with sweep rate adjusted and markers used to define frequency points.

Figure 2-4. Typical CRT Displays of Various Noise Signals.

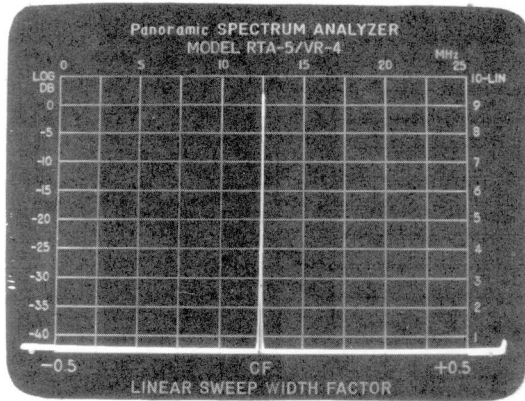

A. Constant carrier signal at approximately maximum sweep width.

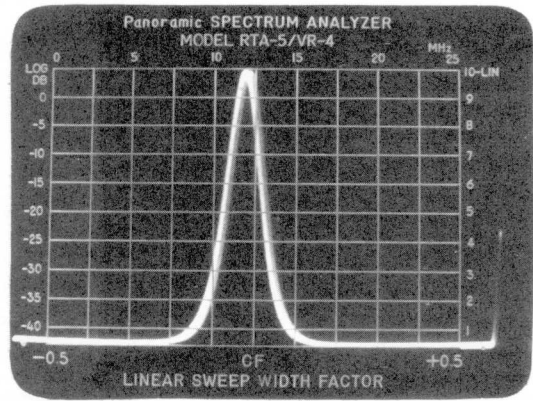

B. Same signal as "A", at reduced sweep width.

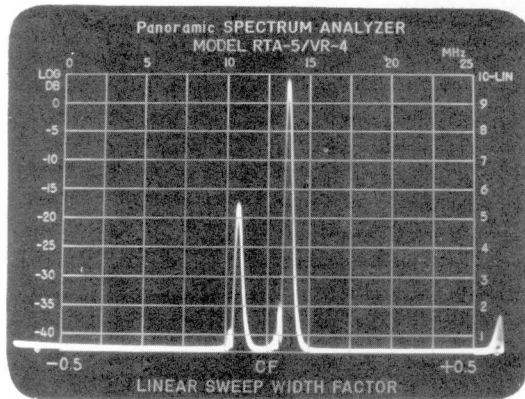

C. Two interfering carriers at optimum resolution.

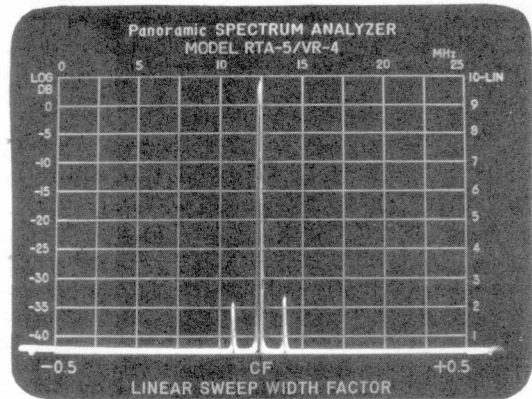

D. Amplitude-modulated (a-m) signal showing carrier at the center and two sidebands.

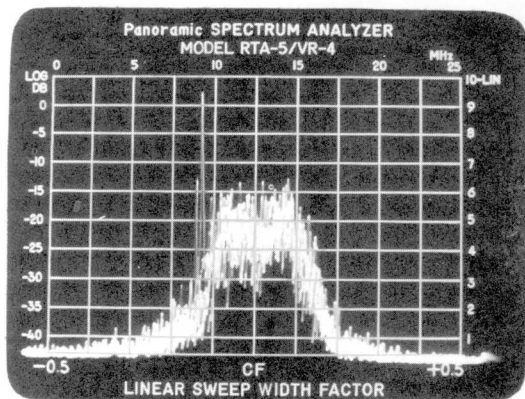

E. Single-sideband signal without carrier suppression.

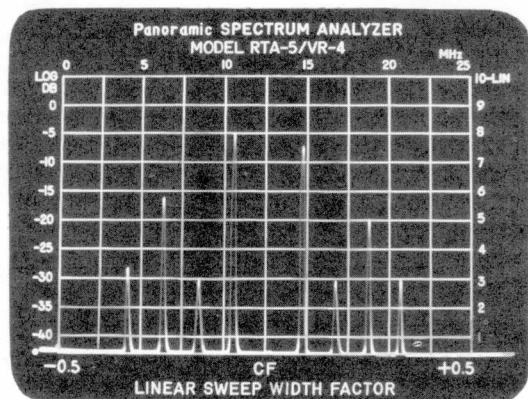

F. Frequency-modulated (f-m) signal with carrier null.

Figure 2-5. Typical CRT Displays of Various Discrete Signals. (Sheet 1 of 2)

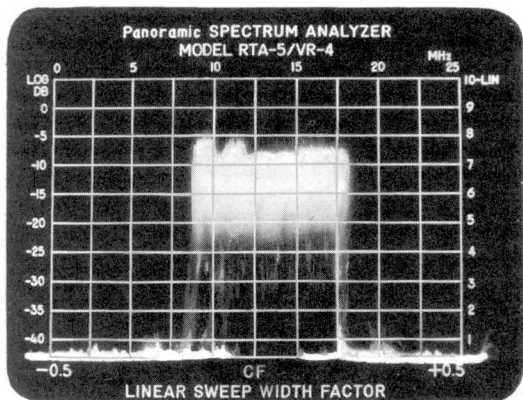

G. Typical sideband energy of f-m signal, speech modulated. (Slow-sweep or long-exposure photography used.)

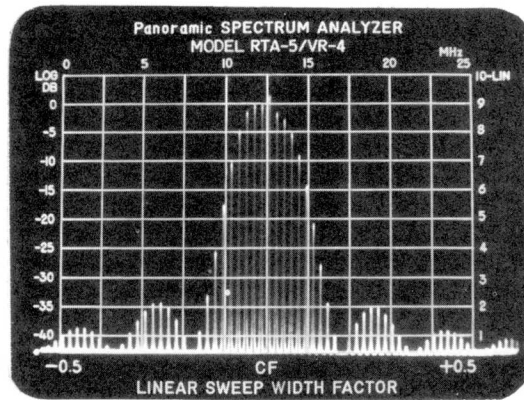

H. Pulsed r-f signal.

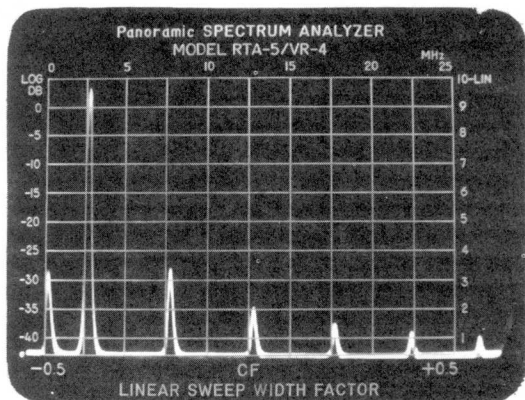

I. 100 kHz square-wave, LIN scale.

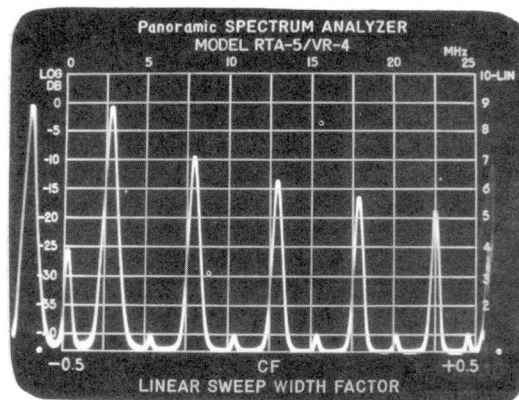

J. 100 kHz square-wave, LOG scale.

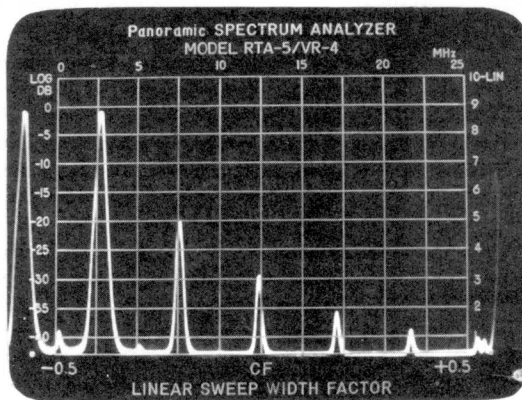

K. 100 kHz triangular wave, LOG scale.

Figure 2-5. Typical CRT Displays of Various Discrete Signals. (Sheet 2 of 2)



## Section II Operation

- a. Oscillator drift - deflection moves slowly across the screen.
- b. Periodic drift - deflection moves back and forth across the screen.
- c. Squeegging - interruption of an oscillator at a-f or i-f rate will result in a spectrum display resembling that of a pulse modulated signal. Sideband components will be present in addition to the oscillating frequency.
- d. Keying - a cw signal appears and disappears in step with the keying of the signal source. During the moments when the signal is off, the frequency sweep axis is closed at the base of the signal. In very rapidly keyed signals the deflection and the baseline are seen simultaneously (on different sweeps).

2-34. Two cw signals which are so close in frequency as to cause aural interference (beats) may appear on the screen as a single signal whose height varies with modulation. As the frequency separation is increased, the signal appears to be modulated on one side only. Further separation will cause a "break" in the apex of the deflection. By reducing the sweep width of the analyzer, the two signals will gradually separate. Reducing the sweep width, reducing the sweep rate, and/or narrowing the i-f bandwidth may result in separation into two distinct pips, see figure 2-5C.

2-35. An amplitude-modulated carrier appears as a deflection of variable height, when the modulating frequency is very low. Non-constant tone modulation of low frequency will produce a series of convolutions varying in height along the sides of the carrier pip. The nature of the presentation will depend upon the sweep width. As the modulation frequency increases, the convolutions move toward the two sides of the deflection, and the sidebands become visible. When the modulation frequency is increased, it becomes possible to separate the sidebands by reducing the sweep width of the analyzer. The IF BANDWIDTH control will enable further separation. The higher the frequency of modulation, the farther away those sidebands will move from the center deflection, which represents the carrier. (See figure 2-5D.)

2-36. The appearance of single-sideband signals depends upon the type of modulation employed. Tone-modulated single-sideband signals appear as a carrier (for a single tone), or a series of carriers (for multi-tones) of slightly different frequency. Voice or music-modulated single-sideband signals appear as a "smear" of rapidly varying signals which occupy finite bandwidth. A typical screen presentation of an amplitude-modulated single-sideband signal without carrier suppression is shown in figure 2-5E.

2-37. Frequency-modulated carriers appear as a series of vertical deflections. See figure 2-5F. A carrier that is frequency-modulated at a low rate appears as a carrier which wobbles sideways. The

vertical deflections shift rapidly when the carrier is modulated by voice or music. See figure 4-5G.

2-38. A pulse-modulated a-m signal (figure 2-5H) will consist of a pattern of vertical spikes. The number of spikes is dependent on the pulse repetition rate, and the i-f bandwidth and the sweep rate of the equipment. The amplitude of each spike represents the amount of energy present at that particular frequency during one of the pulses. The peak envelope of all the spikes represents the energy-distribution pattern of the signal. To measure the pulse width and PRF of a pulsed a-m signal, proceed as follows:

- a. Adjust the SWEEP WIDTH and CENTER FREQUENCY controls so as to obtain one full side lobe with easily resolved spikes on the CRT (see figure 2-6). Record the SWEEP WIDTH dial reading.
- b. Verify that the PRF is greater than the i-f bandwidth by setting the I-F BANDWIDTH control to maximum and adjust the SWEEP WIDTH thumb-wheel control to obtain a number of spikes on the CRT display.
- c. Set the SWEEP WIDTH thumb-wheel control for a conveniently displayed and positioned number of spikes.
- d. Obtain the pulse width by taking the reciprocal of the recorded SWEEP WIDTH dial setting.

### Note

If one side lobe with easily resolved spikes cannot be obtained on CRT display, decrease the setting of the SWEEP WIDTH and I-F BANDWIDTH controls until the spikes are resolved to obtain the PRF.

- e. Obtain the PRF by dividing the recorded SWEEP WIDTH dial setting by the number of spikes on the CRT display (as in the case of figure 2-6, there are 12).

Example:

SWEEP WIDTH dial setting reading = 0.9 MHz

Spikes on CRT = 12

$$\text{Pulse Width} = \frac{1}{0.9 \text{ MHz}} = 1.1 \mu\text{sec}$$

$$\text{PRF} = \frac{0.9 \text{ MHz}}{12} = 75 \text{ kHz}$$

2-39. Square waves can be recognized by a pip at the fundamental frequency and gradually decreasing pips at the odd harmonic frequencies. See figures 2-5I and J.

2-40. Triangular waves can be distinguished from square waves because the amplitudes of the odd

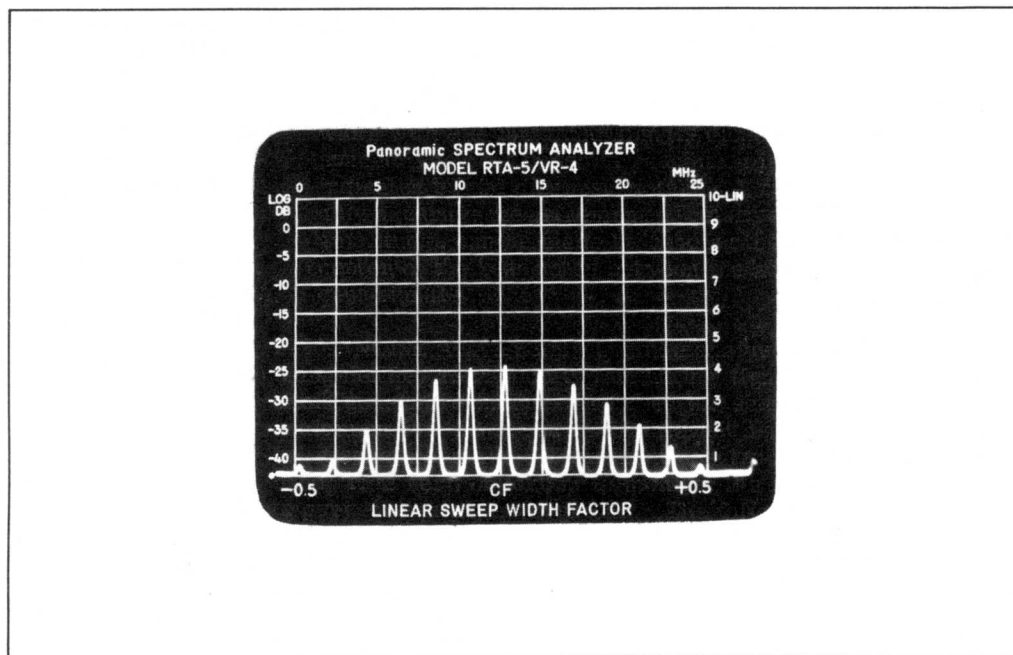

Figure 2-6. Determining Pulse Width and PRF of a Pulsed RF Signal

harmonics decrease much more rapidly with the seventh just barely discernible. See figure 2-5K.

2-41. Radio interference signals of various types may appear on the screen of the spectrum analyzer. Such signals may have broad or narrow spectral distributions, and may occur at constant or at random repetition rates. Signals which occur at a variable repetition rate (such as those produced by accelerating motors, vibrators, buzzers, etc.) may move in one direction or the other along the frequency sweep baseline; this is caused by the fact that the analyzer is sweeping at a fixed rate, whereas the observed signal occurs at a variable rate. The pips stand still on the screen when there is synchronism between the two. Signals produced by such sources as electrical arcing, switching transients, "static," and other short electrical impulses, have broad spectra which may cover the entire frequency range of the analyzer.

2-42. **AMPLITUDE MEASUREMENT OF DISCRETE SIGNALS.** The most accurate method of measuring relative signal strengths that are less than 20 dB apart is to use the linear amplitude presentation on the CRT. When it is necessary to measure two or more signals of widely differing amplitudes (greater than 20 dB but less than 40 dB), the LOG presentation should be viewed on the CRT.

a. Examine the complete spectrum with the SWEEP RANGE switch set to 0-25 MHz PRESET, the AMPLITUDE SCALE set to LOG, the I-F ATTEN DB switch set to 0 DB and VARIABLE control fully CCW. No pips should exceed 10 dB over full scale.

b. Reduce the setting of the INPUT ATTEN DB switch until the largest pip is as large as possible but does not exceed 10 dB over full scale.

#### Note

Failure to limit the input signal could result in incorrect amplitude readings and indications of frequency components that are not present in the input. For best dynamic range (lowest distortion), the I-F ATTEN DB switch should be kept at the lowest possible position.

c. Examine the signal of interest in narrower bands.

#### Note

Signal levels too low to be analyzed in terms of the sensitivity of the equipment can be examined by amplifying them by means of a preamplifier of low noise and distortion, and known gain. The output of the preamplifier must then be considered the signal being analyzed.

d. It is perfectly normal for the amplitude of the zero frequency pip to vary with time. If the frequency region being examined is sufficiently remote from zero so that the zero frequency pip is not on the screen, it is only necessary to be sure that the zero frequency pip is less than full scale on the LOG scale when the I-F ATTEN DB switch is set to 0. It is good practice to confirm the degree of suppression occasionally. If the equipment is used near enough to zero frequency that the zero frequency pip is on the screen, greater care in suppression may be required. If the zero frequency pip is below full scale on the LOG scale with the I-F ATTEN DB switch set to 0 and the signal pips do not tend to ride

## Section II Operation

on the zero frequency pip, the suppression is satisfactory. If the signal pip amplitudes are being influenced by the zero frequency pip, adjust the equipment to improve the resolving capabilities (reduce the sweep width, reduce the sweep rate, or narrow the i-f bandwidth). If improvement of the resolving capabilities does not sufficiently separate the zero frequency pip from the signal pips, adjust the 0 Hz BALANCE controls for suppression of the zero frequency pip sufficient to prevent its influence on the amplitude of the signal pips.

e. To measure signals of comparable amplitude (0 - 20 dB difference), set the AMPLITUDE SCALE switch to LIN. For greater differences, set the switch to LOG. The relative heights of the pip deflections are accurate within the limits of flatness of response of the spectrum analyzer. Better accuracy of amplitude ratio measurement is provided in the LIN position of the AMPLITUDE SCALE switch than in the LOG position. The LIN scale, which is on the right side of the graticule, is divided into ten divisions, numbered from 10 to 1. The LOG scale, at the left side of the graticule, is calibrated from 0 dB to -40 dB in 5-dB increments. For greatest accuracy in comparing the amplitudes of the signals, set the weaker signal to a convenient reference level on the display (LIN scale of the graticule). With the INPUT ATTENUATOR DB switch, reduce the stronger signal until it appears on the calibrated graticule. The relative signal amplitudes, converted from linear ratio to log ratio (decibels) and added to the increase in the INPUT ATTENUATOR DB setting, provides a more accurate measurement than is usually possible from the LOG CRT display.

### Note

Full scale LOG does not correspond to full scale LIN on the graticule calibration.

#### 2-43. FREQUENCY MEASUREMENT OF DISCRETE SIGNALS.

- a. Repeat steps a and b of paragraph 2-42.
- b. Set the SWEEP RANGE switch to 50 KHz - 5 MHz. Adjust the attenuators for a reasonably large signal pip. Set the AMPLITUDE SCALE switch to LIN because the pips are sharper in LIN than in LOG.
- c. Reduce sweep width until the display is limited to the signals of interest.
- d. Measure frequency to within  $\pm 5\%$  by adjusting the CENTER FREQUENCY control until the pip is centered about the CF line. Do not include the ringing pulse as part of the pulse width.
- e. Frequency measurements of greater accuracy may be made by setting the CENTER FREQUENCY control for a reading equal to the frequency of the marker nearest the signal frequency being measured. If the marker is not precisely centered about the CF line, adjust the FREQ CAL control until the marker is centered. Measure signal frequency as in step d.

f. Estimate the frequency of a pip that is not at the center by adding (if the pip is to the right) or subtracting (if the pip is to the left) the displacement in kHz from the center frequency reading. The displacement is determined by multiplying the number of horizontal divisions from CF by one tenth of the sweep width read on the SWEEP WIDTH dial (each horizontal division is equal to 0.1 of the total sweep width). For example:

CENTER FREQUENCY dial reading = 4.00 MHz  
SWEEP WIDTH dial reading = 2.50 MHz, and  
the pip appears at about -3.5. The frequency is approximately:

$$4.00 - (3.5 \times 1/10 \ 2.5) = 4.00 - .875 = 3.125 \text{ MHz}$$

g. When observing signals in NARROW BAND, do not use the CENTER FREQUENCY control to center pips. Return to 50 KHz - 5 MHz, calibrate the CENTER FREQUENCY dial (step e), center the pip carefully, and return to NARROW BAND (through SEARCH LOCK). If the pip is not centered in NARROW BAND, reduce the sweep width until the pip is positioned precisely at one of the horizontal calibrations and compute the frequency as in step f.

2-44. OPERATING PROCEDURES. The following procedure applies to all applications of the Model RTA-5 and TA-2 Spectrum Analyzers, modified in any given instance by the general and special considerations discussed in paragraphs 2-9 through 2-30. Interpretation of spectrum analyzer displays are covered in paragraphs 2-31 through 2-41. Amplitude and frequency measurements are discussed in paragraphs 2-42 and 2-43. It is imperative for a user to read the aforementioned paragraphs thoroughly until familiarity with the equipment is achieved, before attempting to use either model spectrum analyzer. After performing the preliminary operating procedure in paragraphs 2-5 and 2-6, proceed as follows:

- a. Set INPUT ATTEN DB switch to 70 position.
- b. Set I-F ATTEN DB switch to 0 position.
- c. Use any a-c vacuum-tube voltmeter (VTVM) with a suitable frequency response to measure the amplitude of the ac signal to be monitored with the spectrum analyzer. If any signal or pulses having a high crest factor occur in the monitored signal, a peak reading VTVM or oscilloscope should be used. The amplitude of the ac signal should not exceed the voltages listed in table 2-2 for any given input and i-f attenuation setting. Be sure to note whether linear (LIN) or logarithmic (LOG) SCALE AMPLITUDE is being used. Table 2-2 gives input voltages providing full-scale deflection at various total attenuation settings (i. e., of INPUT and I-F ATTEN DB switches).

### CAUTION

THE MAXIMUM INPUT VOLTAGE MUST NOT EXCEED 5 VOLTS RMS.

**CAUTION**

THE MAXIMUM INPUT VOLTAGE FOR ANY INPUT ATTEN DB SETTING SHOULD NOT EXCEED A VALUE EQUAL TO 0 dB GREATER THAN THAT GIVING FULL-SCALE LOG DEFLECTION (ASSUMING THE TOTAL I-F ATTENUATION IS ZERO). EXCEEDING THESE VALUES MAY CAUSE OVERLOADING OF THE INPUT STAGES.

- d. Set I-F ATTEN DB VARIABLE potentiometer to maximum CCW position (0 dB).
- e. Set MARKERS AMPLITUDE potentiometer to fully CW position (MAX).
- f. Set CENTER FREQUENCY 0-25 MHz thumb-wheel control so that associated dial reads 00.0.
- g. Set SWEEP MODE switch to AUTO SCAN position.
- h. Set SWEEP RANGE switch to 0-25 MHz PRESET position.
- i. Set SWEEP WIDTH dial to minimum using adjacent thumb-wheel control.
- j. Set SMOOTHING FILTER potentiometer for maximum CCW position.
- k. Set INPUT 50  $\Omega$  - 75  $\Omega$  switch to the position coinciding with the impedance of the ac signal line to be monitored.

**Note**

For high-impedance line measurement, an optional high-impedance probe is available which is connected by cable to PROBE connector J8 and INPUT connector J6. The high-impedance probe is an active type and is designated as Model PRB-50.

- l. Set AMPLITUDE SCALE switch to LIN or LOG positions as required.
- m. Set MARKERS switch to 5 MHz position.
- n. Adjust FREQ CAL thumb-wheel control so that frequency marker pips coincide with their respective vertical divisions, as indicated on the frequency scale along the top of the graticule.
- o. Connect the signal to be examined to the INPUT connector.
- p. Set the MARKERS switch to the OFF position.
- q. Set the INPUT ATTEN DB and I-F ATTEN DB switches to obtain a full-scale linear or logarithmic deflection (depending on position of SCALE AMPLITUDE switch), using the I-F ATTEN DB VARIABLE

potentiometer for fine adjustment of full-scale amplitude.

**Note**

If possible, use only the INPUT ATTEN DB switch for full scale adjustment, with the I-F ATTEN DB VARIABLE potentiometer used as a vernier. This will make resulting measurements more convenient, with less chance of making an error.

- r. Locate the signal of interest on the CRT display, and notice frequency, estimate spectrum width, using frequency scale across top of graticule.
- s. Set the CENTER FREQUENCY 0-25 MHz dial to the center frequency of the signal of interest, using adjacent thumb-wheel control (large black one).
- t. Set the SWEEP WIDTH dial to the estimated band spectrum width required to include the spectrum occupied by the signal of interest.
- u. Set the SWEEP RANGE switch to 50 kHz - 5 Mhz position.
- v. Set the I-F BANDWIDTH potentiometer to the fully CW position (MAX).
- w. Adjust the CENTER FREQUENCY 0-25 MHz thumb-wheel control so that signal or spectrum of interest is centered at the CF vertical division on the graticule. Adjust the I-F ATTEN DB VARIABLE potentiometer for full scale linear or logarithmic deflection, as required.
- x. Expand the signal display by adjusting the I-F BANDWIDTH potentiometer (in CCW direction) and the SWEEP WIDTH thumb-wheel control, so that signal or spectrum of interest fills the width of the display as much as possible.
- y. If the desired sweep width is less than 50 kHz, set SWEEP RANGE switch to SEARCH/LOCK position.
- z. Adjust the SEARCH/LOCK thumb-wheel control (to the right of the CENTER FREQUENCY thumb-wheel control) so that signal of interest is peaked. Such a peaked display is shown in figure 2-7.

**Note**

This SEARCH/LOCK circuitry is very sensitive and the control must be adjusted very slowly. Also, be certain that the correct signal has been peaked. If using the zero frequency pip for lock-on purposes instead of an external signal, the display will look like a portion of a sine-wave signal (as shown in figure 2-3) instead of a flat-topped plateau.

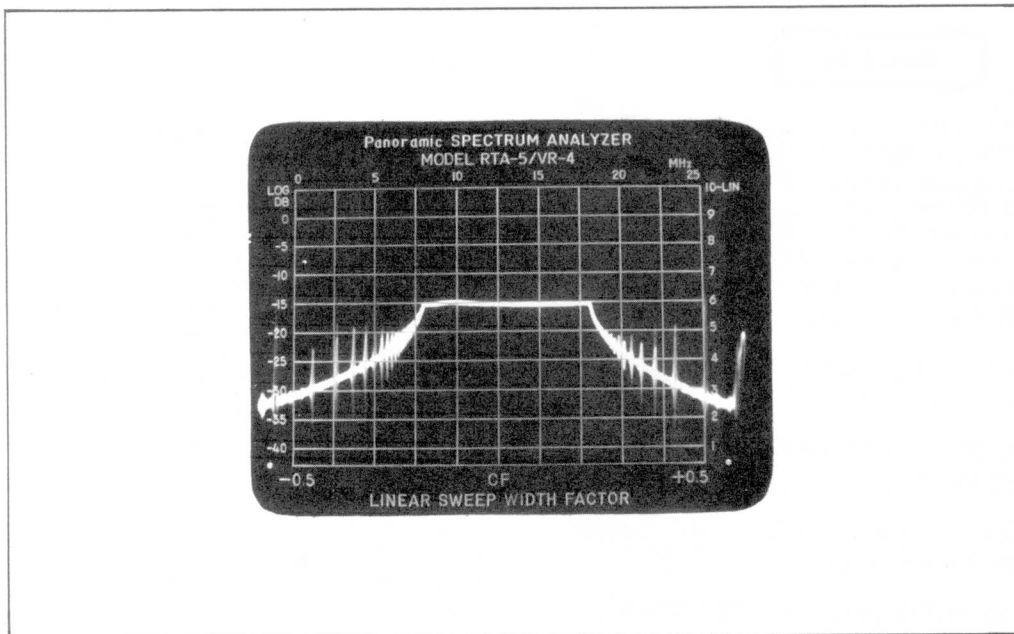

Figure 2-7. Signal Display in Search/Lock Mode.

aa. Set the SWEEP RANGE switch to the 0.5 KHz - 50 KHz NARROW BAND position.

ab. Center the signal of interest on the CRT display using the FINE TUNING NARROW BAND thumb-wheel control, using the CF vertical division for a reference.

ac. Adjust the SWEEP WIDTH thumb-wheel control if necessary to display width of signal of interest on CRT screen.

**Note**

Decreasing the sweep width broadens the signal of interest on the CRT screen while reducing the frequency spectrum displayed.

ad. To resolve closely-spaced pips on the display, adjust the SWEEP WIDTH, sweep rate (VAR) and I-F BANDWIDTH controls, as discussed in paragraph 2-16.

**Note**

See paragraphs 2-31 through 2-43 for information on voltage, frequency, and noise measurements.

## SECTION III

### THEORY OF OPERATION

#### 3-1. GENERAL.

3-2. Video Module, Model VR-4 used in conjunction with Model MF-2 or MF-5 Main Frame, displays the frequency-energy distribution of a signal or group of signals in the range of 0 to 27.5 MHz. It is basically a double-conversion superheterodyne receiver which is automatically and repetitively tuned through a desired portion of the frequency band, with the output displayed as vertical deflections on a CRT screen. Because the horizontal sweep of the CRT is synchronized to the frequency of the swept local oscillator of the receiver, the vertical deflections are automatically positioned along the frequency-calibrated horizontal axis of the CRT screen.

#### 3-3. SIMPLIFIED BLOCK DIAGRAM DISCUSSION.

3-4. The simplified block diagram, figure 3-1, shows the functional relationship of all circuits in the VR-4. All front panel controls, indicators, and connectors are included in the diagram to thoroughly familiarize the user with the function of each.

3-5. The test signal is applied from the INPUT jack to the input attenuator, which has an input impedance of 75 ohms. When an input impedance of 50 ohms is required, the INPUT switch is placed in the 50  $\Omega$  position, thereby shunting the attenuator's input with a suitable resistor. The input attenuation can be adjusted with the INPUT ATTEN DB switch in 10-dB steps from 0 to 70 dB to reduce the level of the input signal and thereby prevent overloading the input circuits of the module. The attenuated signal is applied to the balanced mixer, where it is combined with the swept output of the wide-band local oscillator. The local oscillator operates above the incoming frequency and can be swept from 32.238 MHz to 59.738 MHz. An input discrete frequency combines with the swept local oscillator output to provide a continuously varying difference frequency that is continuously swept from a point somewhat below the i-f frequency to a point somewhat above the i-f frequency; for a finite time during the sweep, the difference frequency will pass through the i-f amplifiers and appear on the CRT screen. At the low-frequency end of the local oscillator sweep, the local oscillator is tuned to the i-f frequency and any imbalance in the balanced mixer will result in an output that passes through the i-f amplifier and appears on the CRT screen as the zero frequency pip. The 0 Hz BALANCE controls adjust the balanced mixer to minimize the local oscillator frequency that appears in the output of the mixer and thereby reduces the zero frequency pip. The i-f

output of the mixer is applied through the 32.238 MHz i-f amplifier to the second mixer. This signal is mixed with a fixed 29.538 MHz output of the crystal oscillator, producing the 2.7 MHz i-f frequency. The 2.7 MHz signal is applied to the 2.7 MHz crystal i-f amplifier. The bandwidth of this amplifier is adjusted in the 50 KHz - 5 MHz and 0.5 KHz - 50 KHz NARROW BAND positions of the SWEEP RANGE switch by the I-F BANDWIDTH control, which adjusts a dc input to the i-f amplifier. Reducing the i-f bandwidth reduces the portion of the local oscillator sweep that produces a signal within the bandpass of the i-f amplifier; therefore the pip resulting from a discrete frequency input appears narrower on the CRT screen, thereby improving the resolution between two signals that are close in frequency. The output of this i-f amplifier is applied through the i-f step attenuator which is controlled by the IF ATTEN DB switch. The i-f attenuator permits adjustment of the pip amplitudes on the CRT screen. The attenuated signal is applied to the fixed-bandwidth 2.7 MHz i-f amplifier. The gain of this i-f amplifier is continuously adjustable over a range from 0 to 10 dB by the I-F ATTEN DB VARIABLE control. This control sets the pip amplitudes to a convenient height for relative amplitude measurements. The output of this i-f amplifier is developed across a linear or nonlinear (log compression) circuit as determined by the position of the AMPLITUDE SCALE switch. The log compression circuit produces an input to the log amplifier whose amplitude is logarithmically related to the amplitude of the input signal to the i-f amplifier. The output of the log amplifier is detected and the video is applied through an emitter follower to another linear or nonlinear network, from which the video output is obtained. When noise signals are being analyzed, a smoothing filter can be used to average the outputs and thereby provide the envelope of the noise pulses to the CRT. The amount of smoothing is continuously controlled by the SMOOTHING FILTER control in all positions of the SWEEP RANGE switch except the SEARCH LOCK position.

3-6. The sawtooth generator produces the sawtooth sweep voltage that is applied to the horizontal deflection circuits of the main frame and also to the two local oscillators in the VR-4. In the 0 - 25 MHz PRESET position of the SWEEP RANGE switch, the sawtooth voltage is applied to the wide-band local oscillator, while the narrow-band local oscillator is disabled. The wide-band local oscillator is a multi-vibrator whose free-running frequency is determined by the instantaneous dc voltage applied to the circuit. Because the full sawtooth voltage is applied to the wide-band local oscillator, the oscillator is swept over its full range of frequencies. In the 50 KHz - 5 MHz position of the SWEEP RANGE switch, an

### Section III Theory of Operation

adjustable portion of the sawtooth voltage is applied to the wide-band local oscillator so that the oscillator is swept only over a portion of its range while the full sawtooth is applied to the CRT circuits. Thus the full CRT sweep represents a controlled portion of the frequency spectrum. The CENTER FREQUENCY control adjusts the dc level of the sawtooth applied to the wide-band local oscillator in this mode. Because the same dc voltage is applied at both sides of the SWEEP WIDTH potentiometer, adjusting the sawtooth amplitude applied to the wide-band local oscillator does not alter the dc component, and therefore does not affect the center frequency. The FREQ CAL control introduces an additional dc component to the wide-band local oscillator to calibrate the CENTER FREQUENCY dial. In the SEARCH LOCK position of the SWEEP RANGE switch, a fixed amplitude sawtooth voltage (with a dc level determined by the CENTER FREQUENCY control) is applied to the wide-band local oscillator, while the same dc level is simultaneously applied to the narrow-band local oscillator. The output of the narrow-band local oscillator is a fixed frequency that is applied to the wide-band local oscillator as a synchronizing input. As the wide-band local oscillator is swept through its range by its sawtooth input, it passes through, and is momentarily synchronized to, the fixed frequency of a narrow-band local oscillator. The change in output that results at this instant appears as a flat-top waveform (figure 2-4) on the CRT screen and the waveform indicates the frequency to which the narrow-band local oscillator is tuned; thus the flat-top waveform allows the narrow-band local oscillator to be retuned by the SEARCH LOCK and FINE TUNING NARROW BAND controls to the center frequency of the wide-band local oscillator. In the 0.5 KHz - 50 KHz NARROW BAND position of the SWEEP RANGE switch, the dc voltage determined by the CENTER FREQUENCY control is applied to the wide-band local oscillator and an adjustable sawtooth voltage is applied to the narrow-band local oscillator. The dc component of this sawtooth is the same in this switch position as it was in the SEARCH LOCK position so that the narrow-band local oscillator's center frequency remains unchanged. The frequencies generated by the narrow-band local oscillator synchronize the wide-band local oscillator so that it, too, is swept through the same limited frequency range. Although its range of frequencies is limited, the narrow-band local oscillator is used because of its greater stability, which results in reduced jitter; jitter would be most noticeable with narrow sweep widths because small frequency differences result in large horizontal displacements. In the 50 KHz - 5 MHz and the 0.5 KHz - 50 KHz NARROW BAND positions of the SWEEP RANGE switch, the operator can select either AUTO SCAN or MANUAL positions of the SWEEP MODE switch. In the AUTO SCAN position of the switch, the sawtooth generator automatically generates sawtooth voltages which repeatedly sweep the local oscillator and CRT screen. In the MANUAL position of the switch, the Sweep Rate (VAR) control adjusts a dc output of the sawtooth generator so that the "scanning" can be manually controlled. In the 0 - 25 MHz PRESET and SEARCH LOCK positions, the SWEEP MODE switch has no effect, and the sawtooth generator operates as though in the AUTO SCAN position.

3-7. When improved frequency-determining capabilities are required, marker pips can be introduced to the CRT display. These pips are generated by the marker generator and introduced at the output of the input attenuator, where they are combined with the input signal and treated as other discrete frequency inputs. When the MARKERS switch is in the OFF position, the marker generator is disabled and no markers appear on the CRT screen. When the switch is in the 5 MHz position, markers appearing at 5-MHz intervals are generated. In the 500 KHz position, the marker generator produces markers spaced every 500 kHz and adds to these the markers spaced at 5 MHz. Similarly in the 25 KHz position, all markers are generated and added so that the 5 MHz markers are largest, the 500 kHz markers are the next largest, and the 25 kHz markers are the smallest. The amplitude of all markers is adjustable by the MARKERS AMPLITUDE control.

### 3-8. DETAILED THEORY OF OPERATION.

3-9. GENERAL. The detailed theory of operation is subdivided into nine parts, in which the individual assemblies are described. This description is based on the detailed block diagram, figure 3-2, and the individual schematic diagrams, figures 5-1 through 5-7.

3-10. INPUT ATTENUATOR ASSEMBLY A9 (See figure 5-1.) The input signal is applied from INPUT connector J6 to input attenuator assembly A9. The input attenuator consists of three pi-connected resistive attenuators (A9R1 through R3, A9R4 through R6, and A9R7 through R9) that can be inserted or bypassed, depending on the position of INPUT ATTEN DB switch A9S1. The three attenuators can insert 10, 20, and 40 dB attenuation, respectively, so that when all three are inserted in cascade, a total attenuation of 70 dB is introduced in the input circuit.

3-11. FIRST MIXER ASSEMBLY A8 (See figure 5-2.) The output from the attenuator is combined with the output of the marker circuits (paragraph 3-23) and applied to the base of phase splitter Q1. The phase splitter provides two out-of-phase signals of different amplitudes. The amplified signal is applied to one side of balanced mixer Q3/Q4. The other output of the phase splitter, which is not amplified, is applied to the emitter of grounded-base amplifier Q2. DISTORTION ADJ screwdriver control R5 adjusts the dc bias on the amplifier for minimum distortion. LEVEL BALANCING ADJ screwdriver control R11 adjusts the gain of amplifier Q2 so that the amplified output from Q2 is equal to the amplified output from phase splitter Q1. This amplified output is applied to the other side of balanced mixer Q3/Q4. The inputs to Q3/Q4 are balanced with respect to ground by 0 Hz BALANCE control R2. The local oscillator output is applied to both emitters of the balanced mixer and the voltages at the collectors are developed across the output transformer and across 0 Hz BALANCE control R3. A voltage obtained from R3 is fed back to the input of Q3 and Q4 so that it adds to (is in phase with) the voltage at one base and

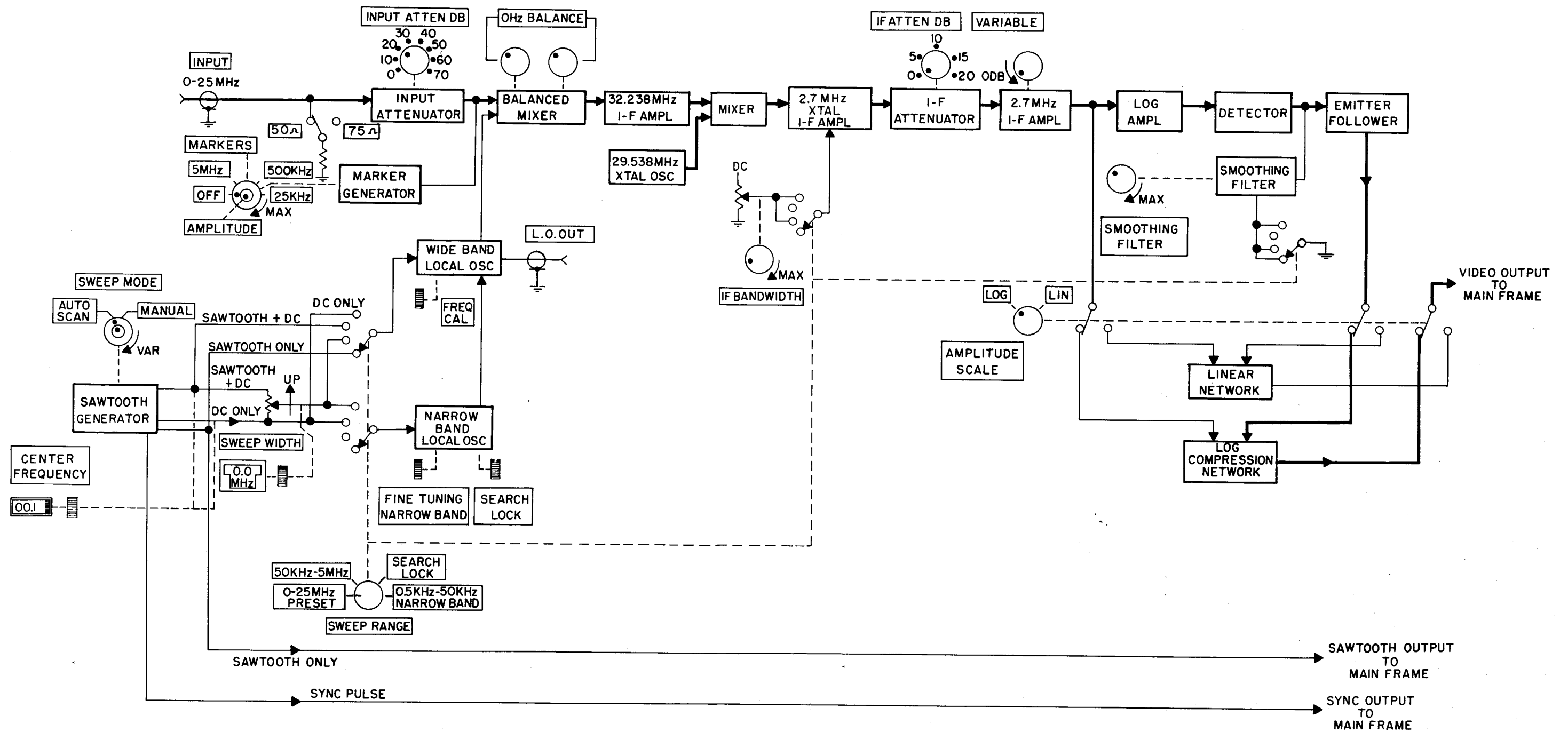

Figure 3-1. Video Module Model VR-4,  
Simplified Block Diagram



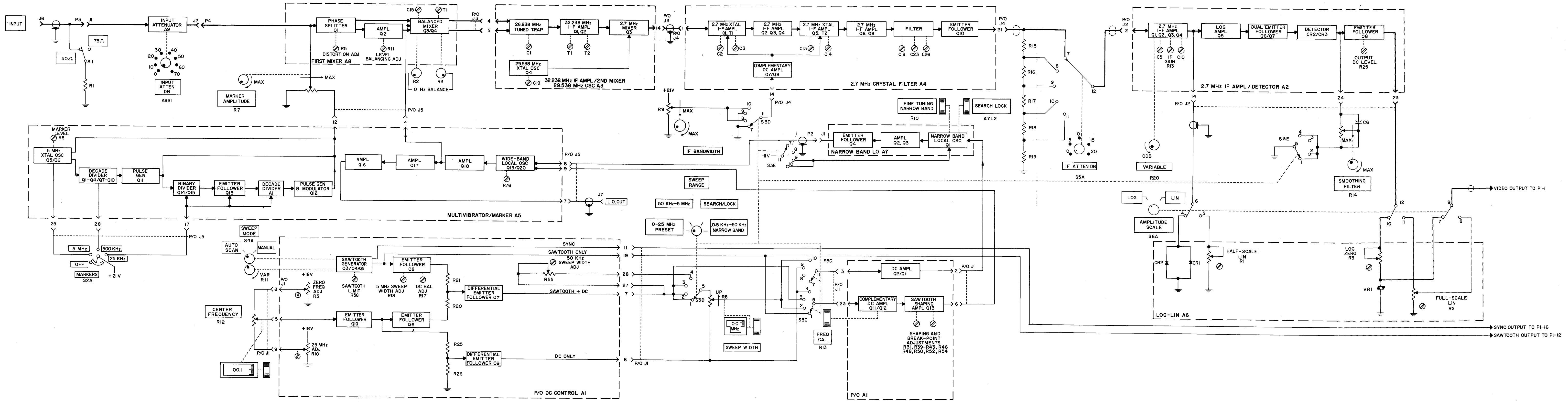

Figure 3-2. Video Module Model VR-4, Detailed Block Diagram

is simultaneously out-of-phase with the voltage at the other base; this compensates for any imbalance in the circuit. C15 and T1 are adjustable and are tuned to the first i-f frequency, 32.328 MHz.

3-12. 32.328 MHz I-F AMPL/2ND MIXER/29.538 MHz OSC ASSEMBLY A3 (See figure 5-3.) The output of the balanced mixer is applied across a series tuned circuit, the 26.838 MHz tuned trap (L1 and C1). This circuit is tuned by screwdriver adjustment C1 to eliminate the 26.838 MHz components that are generated in the balanced mixer as the local oscillator is swept through its range. The 26.838 MHz components represent the image frequency, which would beat in the second mixer with the output of the 29.538 MHz crystal oscillator to provide an erroneous 2.7 MHz i-f signal. If this frequency were not eliminated in the tuned trap, a discrete frequency input would appear as two pips of different amplitudes spaced 5.4 MHz apart; the lower amplitude pip would be produced first and would result from the 26.838 MHz component which would feed through the 32.238 MHz i-f amplifier Q1, Q2 to produce the lower amplitude output; the second pulse would be the desired pulse resulting from a 32.328-MHz output of the balanced mixer. The 32.328 MHz i-f amplifier is a two-stage amplifier with tunable transformer coupling. Crystal oscillator Q4 is tuned by crystal Y1 and adjustable capacitor C19. The output of the second mixer is tuned to 2.7 MHz by capacitor C15.

3-13. 2.7 MHz CRYSTAL FILTER ASSEMBLY A4 (See figure 5-4.) The output of the 2.7 MHz mixer A3Q3 is applied to the 2.7 MHz crystal i-f amplifier A4Q1, T1. This stage is an emitter follower whose output is coupled through 2.7-MHz crystal Y1, which is utilized in its series-resonant mode. The crystal passes the 2.7 MHz signal through the equivalent series resonant circuit, and also passes signals through the capacitance of its holders. An out-of-phase signal is taken from the collector of Q1 to cancel the signal that is applied through the crystal holders; this balancing signal is adjusted by capacitor C2. The primary winding of transformer T1 is tuned to 2.7 MHz by capacitor C3. One of the secondary windings of transformer T1 is controlled by the I-F BANDWIDTH input. In the 0 - 25 MHz PRESET and SEARCH LOCK positions of the SWEEP RANGE switch, ground is applied through one section of S3D (figure 5-1) to the complementary dc amplifier Q7/Q8 and has no effect on the dc amplifier. In the other positions of the SWEEP RANGE switch, an adjustable positive dc voltage is applied to the complementary dc amplifier which applies the positive voltage to the secondary windings of transformers T1 and T2. As the voltage from the I-F BANDWIDTH control becomes more positive (the control set for minimum bandwidth), Q8 represents a greater loading on the two transformers, decreasing the "Q" of the transformers, and decreasing the bandwidth of the circuits. Adjustments C13 and C14 perform the same functions for 2.7 MHz crystal i-f amplifier Q5, T2 as C2 and C3 perform for 2.7 MHz crystal i-f amplifier Q1, T1. The i-f signal from transformer T2 is applied through 2.7 MHz i-f amplifier Q6 and Q9 to a band-pass filter that is tuned to 2.7 MHz by screwdriver adjustments C19, C23, and C26. This filter removes any spurious

frequencies generated by crystals Y1 and Y2. The output is connected through emitter follower Q10 to the i-f attenuator.

3-14. I-F ATTENUATOR. The i-f attenuator, which is shown in figure 5-1, consists of a resistive voltage divider (R15 through R19) from which the output is selected by I-F ATTEN DB switch S5A. When the switch is in the 0 position, the full output of emitter follower A4Q10 is applied through the switch to the 2.7 MHz i-f amplifier in assembly A2.

3-15 2.7 MHz I-F AMPL/DETECTOR ASSEMBLY A2 AND LOG - LIN ASSEMBLY A6 (See figure 5-5 for assembly A2 and figure 5-2 for the log-lin assembly A6). The 2.7 MHz i-f amplifier in assembly A2 consists of emitter follower Q1, tuned amplifiers Q2 and Q3, and untuned amplifier Q4. The gain of amplifier Q2 is adjusted by I-F ATTEN DB VARIABLE control R20, which is part of the degenerative emitter load resistance. The tuned circuit of Q2 is adjusted by capacitor C5; the tuned circuit of Q3 is adjusted by capacitor C10. The gain of amplifier Q3 is adjusted by the I-F GAIN screwdriver control R13, which adjusts the degenerative emitter load resistance for that stage.

3-16. The output of Q4 is applied through the AMPLITUDE SCALE switch S6A (figure 5-1) to log-lin assembly A6. When the switch is in the LIN position, the output of A2Q4 is developed across HALF-SCALE LIN screwdriver control A6R1. When the switch is in the LOG position, the i-f signal is developed across diodes CR1 and CR2; since the diode's current increases exponentially with voltage, the voltage across the diodes is a logarithmic function of the input voltage to A2Q4. The voltage developed in either position of the AMPLITUDE SCALE switch is applied to log amplifier Q5, whose output is applied to dual emitter follower Q6/Q7. The output of the dual emitter follower is coupled through transformer T3 to full-wave detector CR2/CR3. In all positions of the SWEEP RANGE switch except the SEARCH LOCK position, the output of the detector is developed across the smoothing filter consisting of SMOOTHING FILTER control R14 (figure 5-1). Adjusting R14 changes the loading effect of capacitor C23 and therefore affects the frequency response of the detector circuit. The output of the detector is combined with a dc voltage determined by the setting of OUTPUT DC LEVEL screwdriver control R25 and applied to emitter follower Q8. The output of the emitter follower is applied through the AMPLITUDE SCALE switch to log-lin assembly A6 and from A6 through the switch to the vertical deflection circuits in the main frame. The output level is adjusted in log-lin assembly A6 by LOG ZERO screwdriver control R3 (for the LOG position) or FULL-SCALE LIN screwdriver control R2 (for the LIN position).

3-17. DC CONTROL ASSEMBLY A1 (See figure 3-3 and 5-6.) The sawtooth generator (figure 3-3) consists of a unijunction transistor A1Q3 and charging capacitor A1C4. The voltage at which the unijunction transistor breaks down is determined by the adjustment of SAWTOOTH LIMIT screwdriver control A1R58. When the capacitor is charged to this voltage, the unijunction transistor breaks down and discharges

Section III  
Theory of Operation

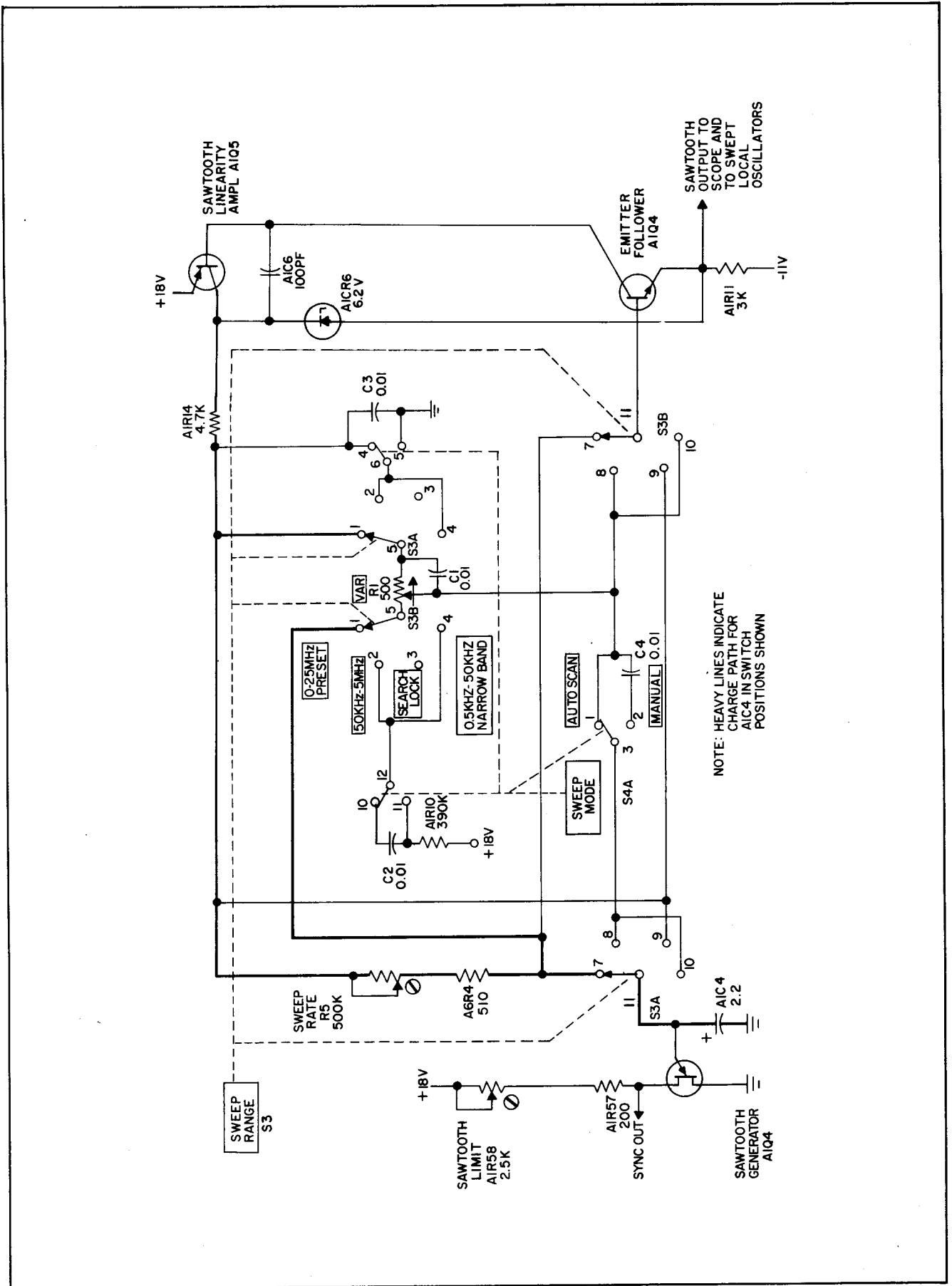

Figure 3-3. Sawtooth Generator, Simplified Schematic Diagram

the capacitor, completing one sawtooth cycle. In the 0 - 25 MHz PRESET position of SWEEP RANGE switch S3, capacitor A1C4 charges through Sweep Rate (VAR) control R1, A6R4 and SWEEP RATE screwdriver control R5, A1R14, and sawtooth linearity amplifier A1Q5. If it were not for the effects of the sawtooth linearity amplifier, capacitor A1C4 would charge nonlinearly; that is the charge rate would decrease as the capacitor charges up. The voltage across the capacitor is applied to emitter follower A1Q4. As capacitor A1C4 charges up, emitter follower A1Q4 conducts more heavily and the impedance of sawtooth linearity amplifier A1Q5 decreases. The decreased impedance of A1Q5 tends to increase the charging current above a constant value as A1C4 charges up. (A constant charging current is required for a linear sawtooth to be generated.) Zener diode A1CR6 maintains the collector voltage of A1Q5 at a fixed voltage above the output of emitter follower A1Q4; this difference voltage is also the voltage developed across the charging resistors, and by maintaining this voltage constant, zener diode A1CR6 assures a linear sawtooth. When the SWEEP RANGE switch is set to the 50 KHz - 5 MHz position, A1C4 charges through the SWEEP MODE switch (in AUTO SCAN) and a portion of Sweep Rate (VAR) control R1. Adjusting this control adjusts the charge rate for A1C4 and therefore the sweep rate. When the SWEEP MODE switch is set to MANUAL, the Sweep Rate (VAR) control is connected between 18 volts and ground, and a dc voltage derived from the control is applied to the emitter follower. Capacitor C4 prevents A1C4 from reaching the voltage needed to break down the uni-junction transistor, and the sawtooth generator is disabled. When the SWEEP RANGE switch is set to SEARCH LOCK, A1C4 charges directly through A1R14 and A1Q5, providing a sweep speed equivalent to the fastest speed obtainable in the 50 KHz - 5 MHz position. The circuit functions identically in the 0.5 KHz - 50 KHz NARROW BAND position and in the 50 KHz - 5 MHz position of the SWEEP RANGE switch.

3-18. The sawtooth output from the sawtooth generator is applied to emitter follower Q8, and to the horizontal deflection circuits in the main frame. The sawtooth voltage applied to the horizontal deflection circuits provides the horizontal sweep on the CRT, while the sawtooth applied to emitter follower Q8 is used to sweep one or the other of the swept local oscillators (except in the 0 - 25 MHz PRESET position of the SWEEP RANGE switch, when the full sawtooth that is applied to the horizontal deflection circuits is used to sweep the wide-band local oscillator). The amplitude of the sawtooth that is applied to emitter follower Q8 is adjusted by the 5 MHz SWEEP WIDTH ADJ screwdriver control R18, and the dc component of the sawtooth applied to emitter follower Q8 is adjusted by DC BAL ADJ screwdriver control R17. Screwdriver control R18, by adjusting the sawtooth amplitude applied to emitter follower Q8, limits the maximum drive that can be applied from the SWEEP WIDTH control to the wide-band local oscillator and therefore sets the maximum sweep width at 5 MHz. Screwdriver control R17 introduces a negative dc voltage to the emitter follower so that

the average dc voltage of the sawtooth at Q8 is zero; the dc voltage is important since it determines the center frequency of the swept local oscillators. The desired dc voltage is obtained from CENTER FREQUENCY control R12. The dc voltage across R12 is adjusted by 0 FREQ ADJ screwdriver control R3 and 25 MHz ADJ screwdriver control R7. Screwdriver control R3 determines the voltage that will be obtained from CENTER FREQUENCY control R12 when it is set for 0 center frequency; screwdriver control R7 determines the voltage that will be obtained from CENTER FREQUENCY control R12 when it is set for a center frequency of 25 MHz. The dc voltage from the CENTER FREQUENCY control is applied through emitter follower Q10 and emitter follower Q6. The output of emitter follower Q6 and the sawtooth output from emitter follower Q8 are combined in an averaging circuit consisting of R21 and R20. The output from the averaging circuit, which is equal to half of the sawtooth output of Q8 plus half of the dc output from Q6, is applied to emitter follower Q7. The dc output from emitter follower Q10 is halved by voltage divider R25/R26 and applied to emitter follower Q9. The dc output of Q9 is therefore equal to the dc output of Q7.

3-19. The sawtooth, sawtooth-plus-dc, or dc input to the wide-band local oscillator is controlled by the SWEEP RANGE switch. In the 0 - 25 MHz PRESET position of the switch, the full sawtooth output of the sawtooth generator is applied through terminal 5 of S3C, the complementary dc amplifier Q11/Q12, and sawtooth shaping amplifier Q13 to the wide-band local oscillator. Because the wide-band local oscillator does not provide a linear sweep in frequency for a linear sawtooth input, the linear sawtooth that is applied through the complementary dc amplifier is reshaped to a curve that compensates for the nonlinear frequency-voltage characteristic of the wide-band local oscillator. Reshaping of the linear sawtooth sweep is accomplished by varying the load resistance (and consequently the gain) of Q13 in step with the applied linear sawtooth sweep. With no linear sawtooth sweep applied to Q13, diodes CR9 through CR13 are back-biased to cut-off by screwdriver controls R46, R48, R50, R52, and R54 and the load resistance of Q13 consists of R31 through R37. At a certain level of the applied linear sawtooth sweep, diode CR13 conducts, connecting R43 through R54 in series-parallel with R31 through R37, thereby reducing the load resistance of A1Q13. Similarly, at other points of the applied linear sawtooth sweep, diodes CR12, CR11, CR10, and then CR9 conduct, further reducing the load resistance of Q13, producing a non-linear output (curved waveform) from the applied linear sawtooth waveform. Screwdriver controls R39 through R43 vary the slope of the non-linear output waveform. In the 50 KHz - 5 MHz position of the SWEEP RANGE switch, the sawtooth-plus-dc output of A1Q7 is applied to one side of SWEEP WIDTH control R8 while the dc output from A1Q9 is applied to the opposite side of the SWEEP WIDTH control. Adjusting R8 adjusts the amplitude of the sawtooth that is applied to the complementary dc amplifier; adjusting this control does not affect the dc component since the dc voltage is the same at all points along

### Section III Theory of Operation

the control. **FREQ CAL** control R13 adjusts the dc input to the complementary dc amplifier to calibrate the **CENTER FREQUENCY** dial. When the **SWEEP RANGE** switch is set to **SEARCH LOCK**, the full sawtooth-plus-dc output of emitter follower A1Q7 is applied to the complementary dc amplifier. This assures a 5-MHz wide sweep of the wide-band local oscillator so that the frequency of the narrow-band local oscillator can be found on the CRT screen. When the **SWEEP RANGE** switch is set to 0.5 KHz - 50 KHz **NARROW BAND**, the dc output of A1Q9 is applied to the complementary dc amplifier. As a result of the switching just described, the **CENTER FREQUENCY** control has no effect on the wide-band local oscillator in the **PRESET** position and the wide-band local oscillator is swept through its maximum range; in the 50 KHz - 5 MHz position, the wide-band local oscillator is swept about a center frequency determined by the dc component set by the **CENTER FREQUENCY** control and adjusted by the **FREQ CAL** control and is swept over a range determined by the **SWEEP WIDTH** control; in the **SEARCH LOCK** position, the wide-band local oscillator is swept over a 5-MHz range, 2.5 MHz either side of the frequency determined by the **CENTER FREQUENCY** control; in the 0.5 KHz - 50 KHz **NARROW BAND** position, the wide-band local oscillator receives a dc input (no sawtooth) which controls the center frequency of the wide-band local oscillator to keep it near the frequency of the narrow-band local oscillator.

3-20. The input to the narrow-band oscillator is also controlled by the **SWEEP RANGE** switch. In the 0 - 25 MHz **PRESET** and 50 KHz - 5 MHz positions of the switch, operating voltage (-11 vdc) is not applied to the narrow-band local oscillator and the oscillator is disabled. In the **SEARCH LOCK** position, the dc voltage from A1Q9 is applied from terminal 11 of S3C through dc amplifier Q1/Q2 to the narrow-band local oscillator. In this position, the **CENTER FREQUENCY** control determines the frequency of oscillation of the narrow-band local oscillator, and the local oscillator is not swept. In the 0.5 KHz - 50 KHz **NARROW BAND** position, a portion of the voltage across the **SWEEP WIDTH** control is applied through the dc amplifier to the narrow-band local oscillator. The voltage across the **SWEEP WIDTH** control is less than it is in the 50 KHz - 5 MHz position; the voltage is adjusted by the 50 KHz **SWEEP WIDTH ADJ** screwdriver control A1R55. Since the maximum sweep width voltage is less in this position, the voltage applied to the narrow-band local oscillator is less, and the sweep width is reduced.

3-21. **NARROW-BAND LOCAL OSCILLATOR ASSEMBLY A7** (see figure 5-2). The tuned circuit of narrow-band local oscillator Q1 contains varactor CR1, whose capacitance is a function of the instantaneous voltage applied. The voltage applied to one side of the varactor is the dc or sawtooth-plus-dc selected by the **SWEEP RANGE** switch; the dc voltage applied to the other side of the varactor is derived from **FINE TUNING NARROW BAND** control R10. In addition, the tuned circuit contains **SEARCH LOCK** control L2 which adjusts the tuned circuit so

that its center frequency corresponds to the center frequency of the wide-band local oscillator. The output of the local oscillator is applied through amplifiers Q2 and Q3 and emitter follower Q4 to the wide-band local oscillator.

3-22. **MULTIVIBRATOR/MARKER ASSEMBLY A5** (see figure 5-7). The wide-band local oscillator (Q19 and Q20) is a free-running multivibrator whose natural frequency of oscillation is affected by the capacitance of varactor A5CR15. The instantaneous voltage across the capacitor is affected by the sawtooth, sawtooth-plus-dc, or dc voltage selected by the **SWEEP RANGE** switch (which is applied to one side of the varactor) and a fixed dc voltage adjusted by screwdriver control R76 (which is applied to the other side of the varactor). In the **SEARCH LOCK** position of the **SWEEP RANGE** switch, the fixed frequency output of the narrow-band local oscillator is applied to the wide-band local oscillator as a synchronizing input. The wide-band local oscillator is swept by the sawtooth input and, as it approaches the same frequency as the narrow-band local oscillator, is momentarily locked in to the narrow-band frequency. As the sawtooth input increases, a point is reached beyond which synchronization is lost. The wide-band local oscillator then continues to free-run for the remainder of the sweep. The output of the wide-band local oscillator is applied through amplifier Q18 to the balanced mixer and to two-stage amplifier Q17, Q16. The local oscillator signal is applied from the two-stage amplifier to L.O. OUT jack J7 for application to the Model G-6 Companion Sweep Generator.

3-23. The generation of markers is controlled by **MARKERS** switch S2A. When the switch is in the **OFF** position, operating voltage is removed from the 5 MHz crystal oscillator, and no markers are generated. In the 5 MHz position of the switch, operating voltage is applied to the oscillator but not to any of the dividers and markers only at 5 MHz and at harmonic-frequency points (10, 15, 20, and 25 MHz) are generated. The amplitude of the 5 MHz markers is adjusted by **MARKER LEVEL** screwdriver control R8. When the switch is in the 500 KHz position, operating voltage is applied to the crystal oscillator and to decade divider Q1-Q4/Q7-Q10. The 5-MHz output of the crystal oscillator is applied to the decade divider which consists of four flip-flops with appropriate feedback to reduce the recycling count from a normal 16 to 10. The 500-kHz output of the decade divider is applied through pulse generator Q11 to the output. When the switch is in the 25 KHz position, operating voltage is applied to the crystal oscillator and the decade divider, and to binary divider Q14/Q15, emitter follower Q13, and decade divider A5A1. The 500-kHz output of pulse generator Q11 is applied to binary divider Q14/Q15 which reduces the frequency to 250 kHz. This frequency is coupled through emitter follower Q13 to decade divider A1. The 25-kHz output of the decade divider is applied through pulse generator and modulator Q12 to the output, where it is combined with the 500-kHz output of pulse generator Q11 and the 5-MHz output of the crystal oscillator. The output is developed

across MARKERS AMPLITUDE control R7 and an adjusted portion of the marker amplitudes is applied from the control to first mixer assembly A8.

3-24. POWER DISTRIBUTION. Dc power for the operation of video module VR-4 is applied from the main frame when the module is inserted. The -11 vdc and +21 vdc are applied from the main frame; several additional voltages are generated internally in dc control assembly A1 (figure 5-6). Zener diode CR7, dropping resistor R12, and filter capacitor C7 form a power supply that provides -9 vdc derived from the -11 vdc input. The zener-controlled voltage is applied to emitter followers A1Q8, Q7, and Q9. Zener diodes CR4 and CR5, dropping resistor R5, and filter capacitor C3 provide a +18.2 vdc

output (derived from the +21 vdc input) that is used in the sawtooth generator. In addition this voltage is used for the Sweep Rate (VAR) control in MANUAL. Zener diodes CR2 and CR3, dropping resistor R4, and filter capacitor C2 also derive a +18.2 vdc output from the +21 vdc input; this voltage is used to set the voltage across the CENTER FREQUENCY control and as operating voltage for the narrow-band dc amplifier A1Q1/Q2, emitter followers A1Q6 through Q10, the complementary dc amplifier A1Q11/Q12, sawtooth shaping amplifier A1Q13, and wide-band local oscillator A5Q19/Q20. Zener diode CR1, dropping resistor R2, and filter capacitor C1 provide a +5.1 vdc output from the +21-volt input. This voltage, which is applied back to the main frame via P1-6, has been included for future applications.

## SECTION IV MAINTENANCE

### 4-1. GENERAL.

4-2. This section provides information for testing, troubleshooting, repairing, and aligning Video Module VR-4. Procedures are given for visual inspection of the module, for minimum performance tests (to determine whether or not the module is operating within its specifications), for aligning the module, and for locating defective components in the module. Voltage measurements are also included.

4-3. All of the procedures given in this section should be performed with the VR-4 module removed from the main frame, but connected electrically, to it. The extension cable provided with the main frame (both models) should be used for this purpose. Some of the procedures also require that one of the plug-in boards in the VR-4 module be removed from the module, but connected electrically to it. The extender board (figure 4-1) provided with the VR-4 module should be used for this purpose.

4-4. Maintenance of the VR-4 Module requires trained personnel and the use of specialized test equipment, both of which are available at The Singer Company. To arrange for factory maintenance or to request assistance with any maintenance problem, contact the Service Department of The Singer Company, Metrics Division, Bridgeport, Connecticut.

### 4-5. TEST EQUIPMENT REQUIRED.

4-6. The test equipment required for complete testing of the VR-4 module is given in table 4-1. Equivalent test equipment may be substituted if the specified test equipment is not available.

### 4-7. PRELIMINARY INSPECTION.

4-8. **PRELIMINARY INSPECTION ROUTINES.** The purpose of the preliminary inspection is to detect and correct conditions that might otherwise lead to equipment breakdown. Table 4-2 gives a preliminary inspection routine for the VR-4 module.

4-9. **COMPONENT LOCATIONS.** Printed circuit boards, all solid-state design, and convenience of maintenance are features of the VR-4 module. The module consists of eight printed-circuit board assemblies and associated chassis-mounted components. The location of these board assemblies and all of the adjustments in the VR-4 module are illustrated in figures 4-2 through 4-9.

### 4-10. MINIMUM PERFORMANCE STANDARDS CHECKS.

4-11. The minimum performance checks provide a quick and convenient means for determining whether or not the VR-4 module is operating within its specifications. Table 4-3 lists the checks that should be performed, gives the procedure for performing each check, and describes the result that should be obtained from each check. Figure 4-10 shows the test equipment setup for the checks. The minimum performance checks for the VR-4 module assume that the associated main frame is operating within its specifications. Thus, the performance of the main frame should be verified, by means of the tests given in the instruction manual for the main frame, before proceeding.

#### Notes

1. The VR-4 module must be removed from the main frame, but electrically connected to it for step 2 of the checks. The extension cable provided with the main frame can be used for this purpose.
2. The steps given in the table must be performed in numerical order starting with number 1 and ending with number 15. None of the individual steps is a complete check within itself.

4-12. Before performing the procedure given in table 4-3, set the operator's controls at the preliminary positions described below, and adjust the zero pip as described in Section II.

#### Note

Allow the equipment (both module and main frame) to warm up for 30 minutes before commencing with the checks.

- a. On the VR-4 module:

INPUT ATTEN DB switch	70
CENTER FREQUENCY	00.0 MHz
I-F ATTEN DB switch	20
I-F ATTEN DB VARIABLE control	fully CCW
MARKERS switch	OFF
SWEEP WIDTH control	5 MHz
SWEEP RANGE switch	50 kHz - 5 MHz
AMPLITUDE SCALE switch	LOG
SMOOTHING FILTER control	fully CCW

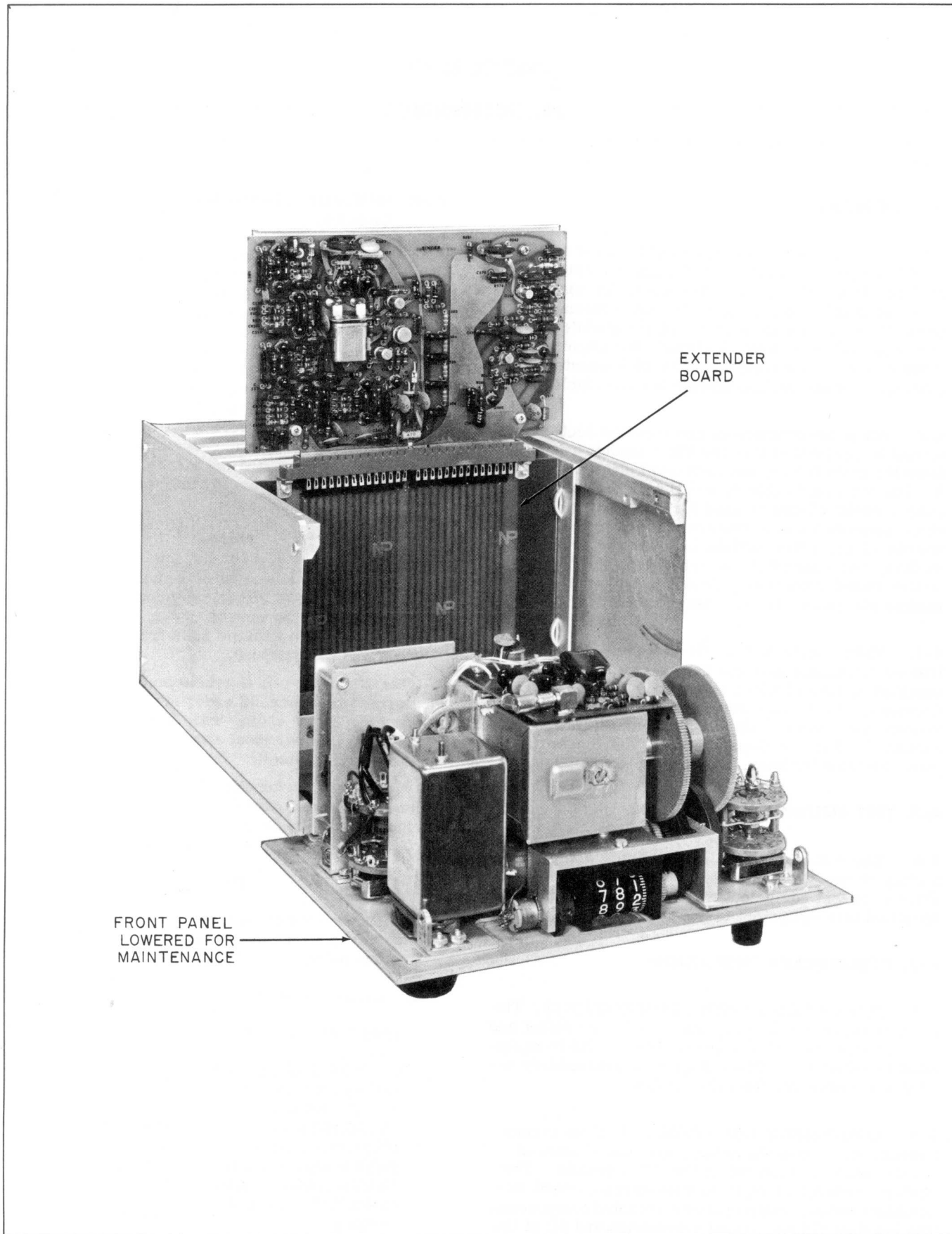

Figure 4-1. Extender Board



TABLE 4-1. TEST EQUIPMENT REQUIRED

Type of Equipment	Type or Model	Manufacturer
Counter	5244L	Hewlett-Packard
Oscilloscope	541 with Type L Plug-in Head	Tektronix
Signal Generator, Low Frequency	200 CD	Hewlett-Packard
Signal Generator, High Frequency,	606A	Hewlett-Packard
Signal Generator, Two Tone	TTG-2	Singer
Step Attenuator, 50-ohm	30-0	Kay
Stop Watch	] Any Commercial Model ] Any Commercial Model	
Taper Attenuator, 100:1 (600-ohm to 50-ohm)		
VTVM, AC Low Frequency	300H	Ballantine
VTVM, AC High Frequency	340	Ballantine
VTVM, DC	WV-98C	RCA
Wave Analyzer	302 A	Hewlett-Packard

TABLE 4-2. PRELIMINARY INSPECTION ROUTINE

Item	Inspect For	Corrective Action
Module case and panels	Dirt and corrosion	Clean with cloth moistened with cleaning solvent (trichloroethylene or equivalent).
Knobs, screws, connectors and clamps	Looseness	Tighten.
Wiring	Dirt, dust, and/or corrosion	Clean with cloth, aerosol spray, syringe, or camel's hair brush using trichloroethylene or equivalent cleaning solvent.
Solder joints	Loose or cold solder connections; corrosion	Clean carefully and resolder.
Capacitors	Leaks, bulges, signs of aging	Replace.
All connectors	Looseness, bent or corroded contacts, signs of aging	Clean contacts with cloth moistened with cleaning solvent (trichloroethylene or equivalent).
Resistors	Cracks, chipping blistering discoloration, and other signs of overheating.	Replace.  <b>Note</b>  Insure that overheating is not due to other defective components.
Switches	Looseness	Tighten mounting hardware.

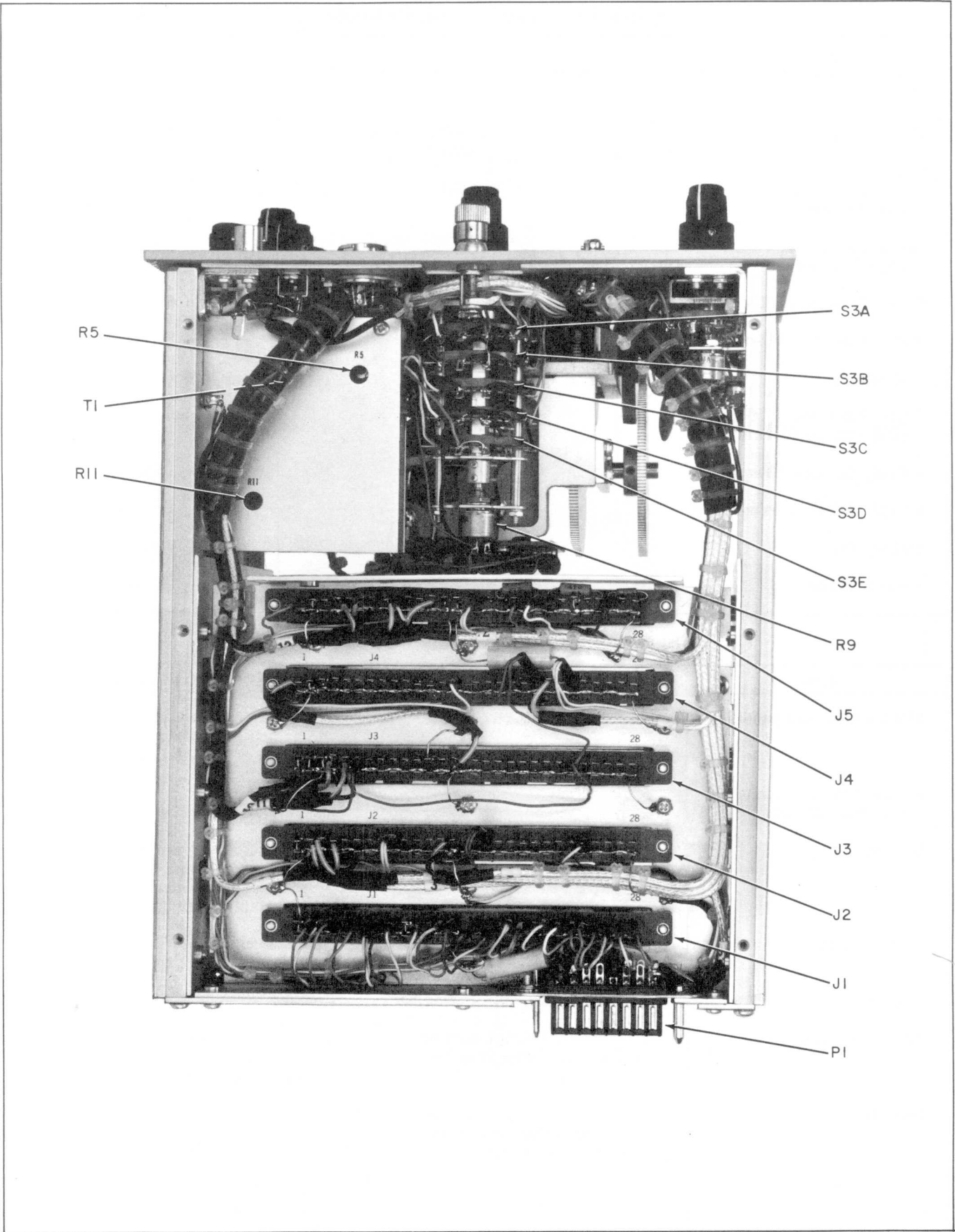

Figure 4-2. Video Module Model VR-4, Bottom View

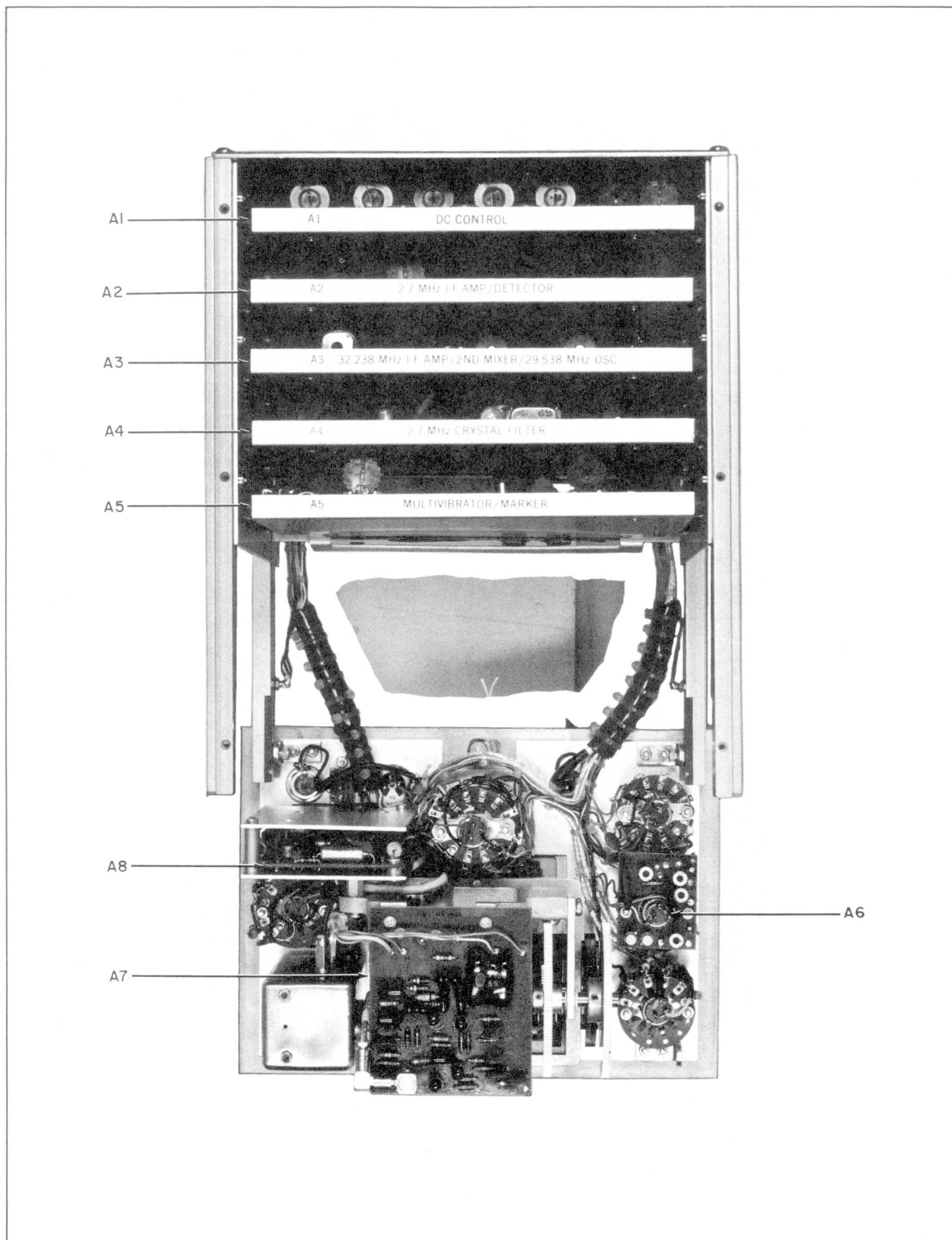

Figure 4-3. Printed Circuit Module Location



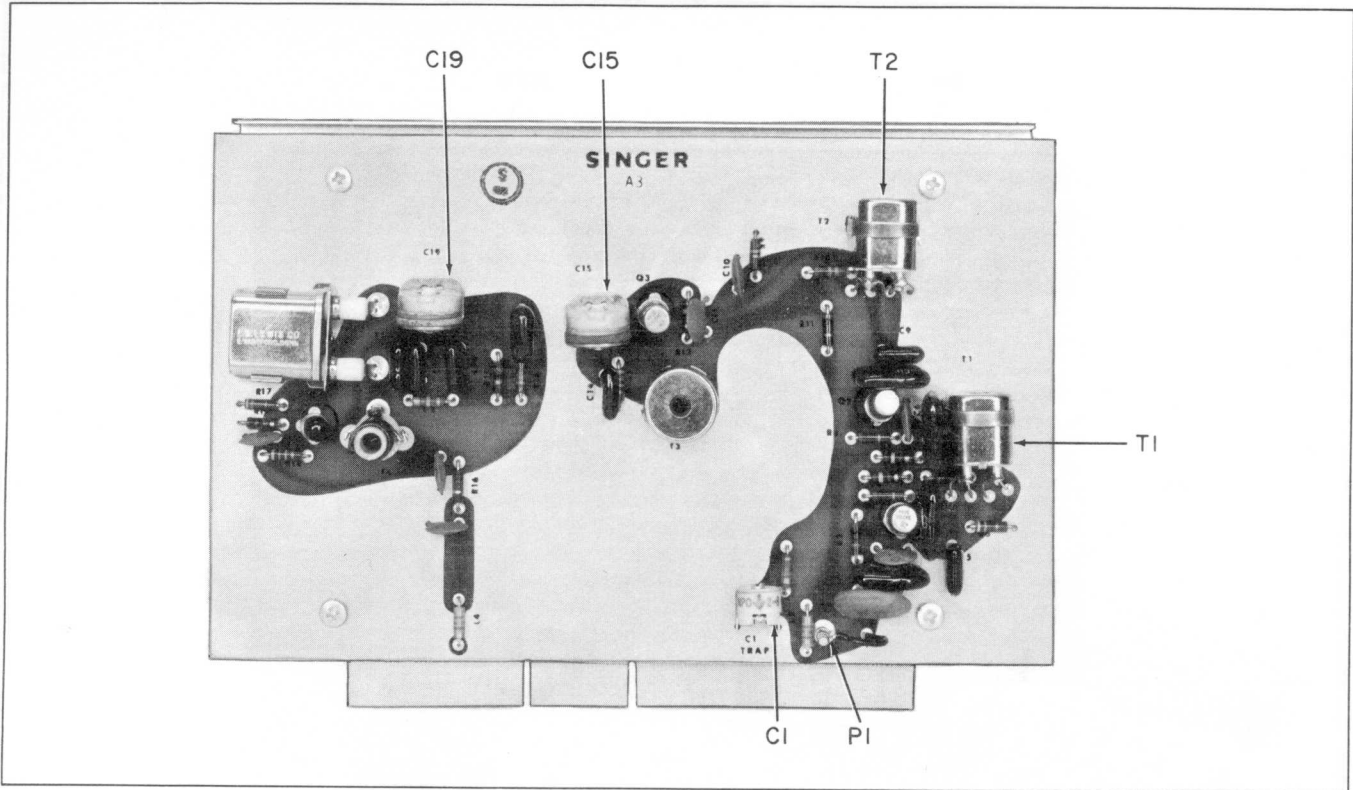

Figure 4-6. 32.238 MHz I-F Ampl/2nd Mixer/29.538 MHz Osc Module A3, Adjustment Locations

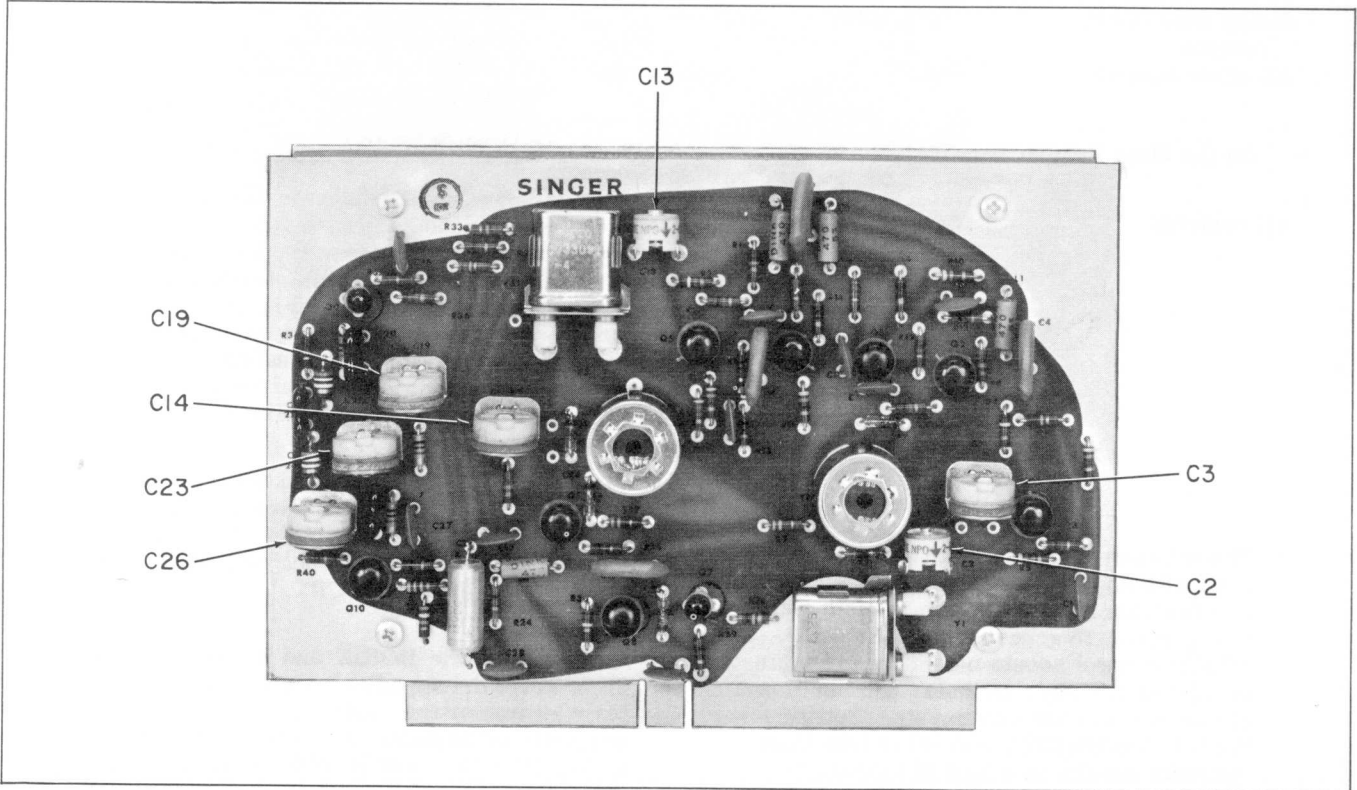

Figure 4-7. 2.7-MHz Crystal Filter Module A4, Adjustment Locations

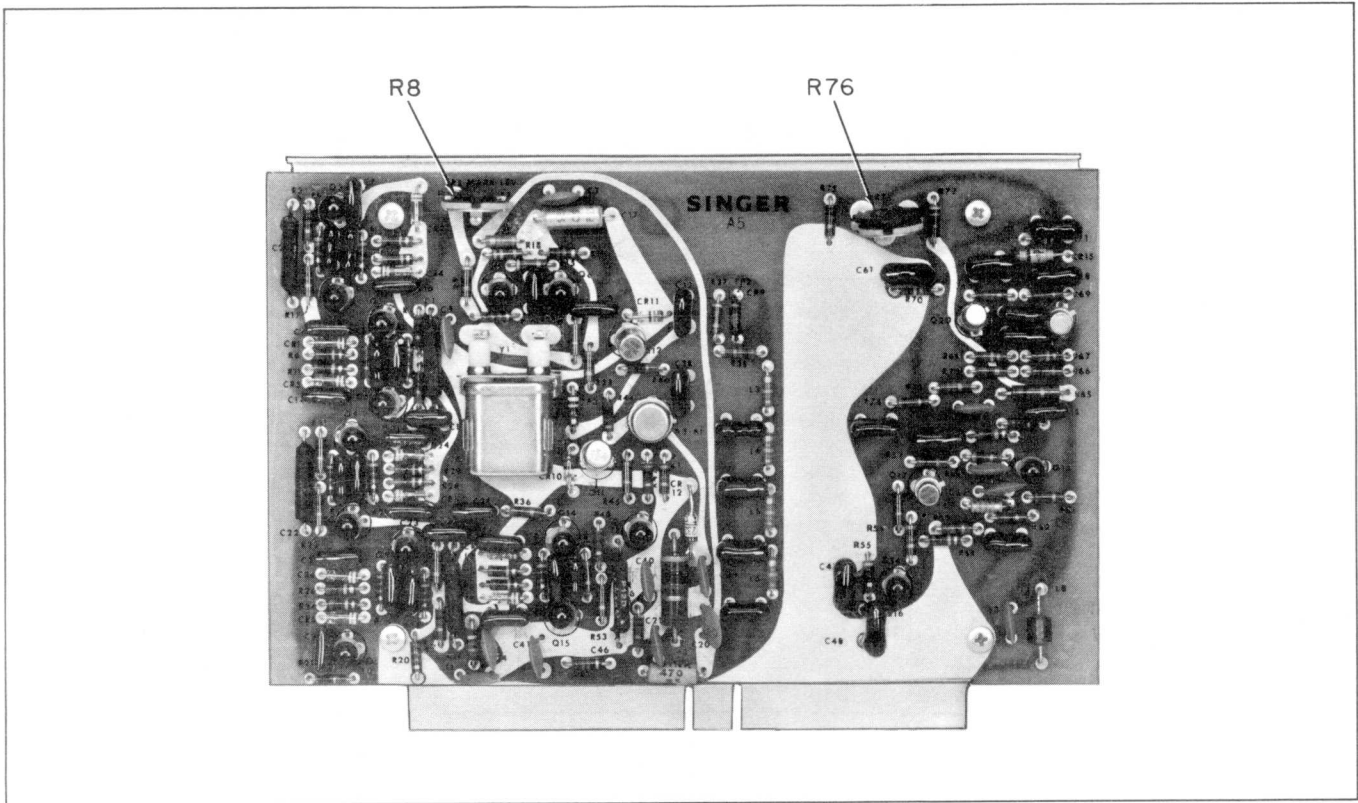

Figure 4-8. Multivibrator/Marker Module A5, Adjustment Locations

I-F BANDWIDTH control	fully CW (See notes below)
SWEEP MODE switch	AUTO SCAN
Sweep Rate (VAR) control	Mid position
All other controls	any

2. Since the sweep width, sweep rate, and i-f bandwidth are independently variable in the VR-4, it may be necessary to readjust the I-F BANDWIDTH control for optimum (unless otherwise instructed in text) periodically throughout the following procedures.

b. On the Main Frame:

All controls	As required to produce a clear sharp trace on the CRT that is centered horizontally and coincides with the baseline on the graticule.
--------------	---

**4-13. TOUCHUP ALIGNMENT.**

4-14. The Video Module has been factory aligned and therefore should not require re-alignment under normal conditions. However, since the module has been aligned with a particular main frame, the procedure outlined below should be performed when the module is installed in another main frame. This ensures all accuracy of the instrument. If this procedure does not give the required results, perform the adjustment procedure outlined in paragraph 4-19.

**Notes**

1. The minimum i-f bandwidth which can be used with any particular set of conditions is a function of both the sweep width and sweep rate. In general, the I-F BANDWIDTH control should be set for optimum resolution for any particular combination of sweep width and sweep rate. Setting the I-F BANDWIDTH control to less than optimum results in a loss of amplitude and resolving capabilities and therefore should be avoided.

a. Set the SWEEP RANGE switch at 0-25 MHz PRESET, the MARKERS switch at 5 MHz, and the AMPLITUDE SCALE switch to LOG. Adjust the MARKERS AMPLITUDE controls, as necessary, to display markers on the CRT.

b. Adjust the HORIZ and HORIZONTAL LINE SIZE screwdriver adjustments on the Model MF-2 Main Frame or the HORIZ POS control and H SIZE screwdriver adjustment on the Model MF-5 until the 0, 5-, 10-, 15-, and 20-MHz markers appear under their corresponding graduations on the CRT graticule.



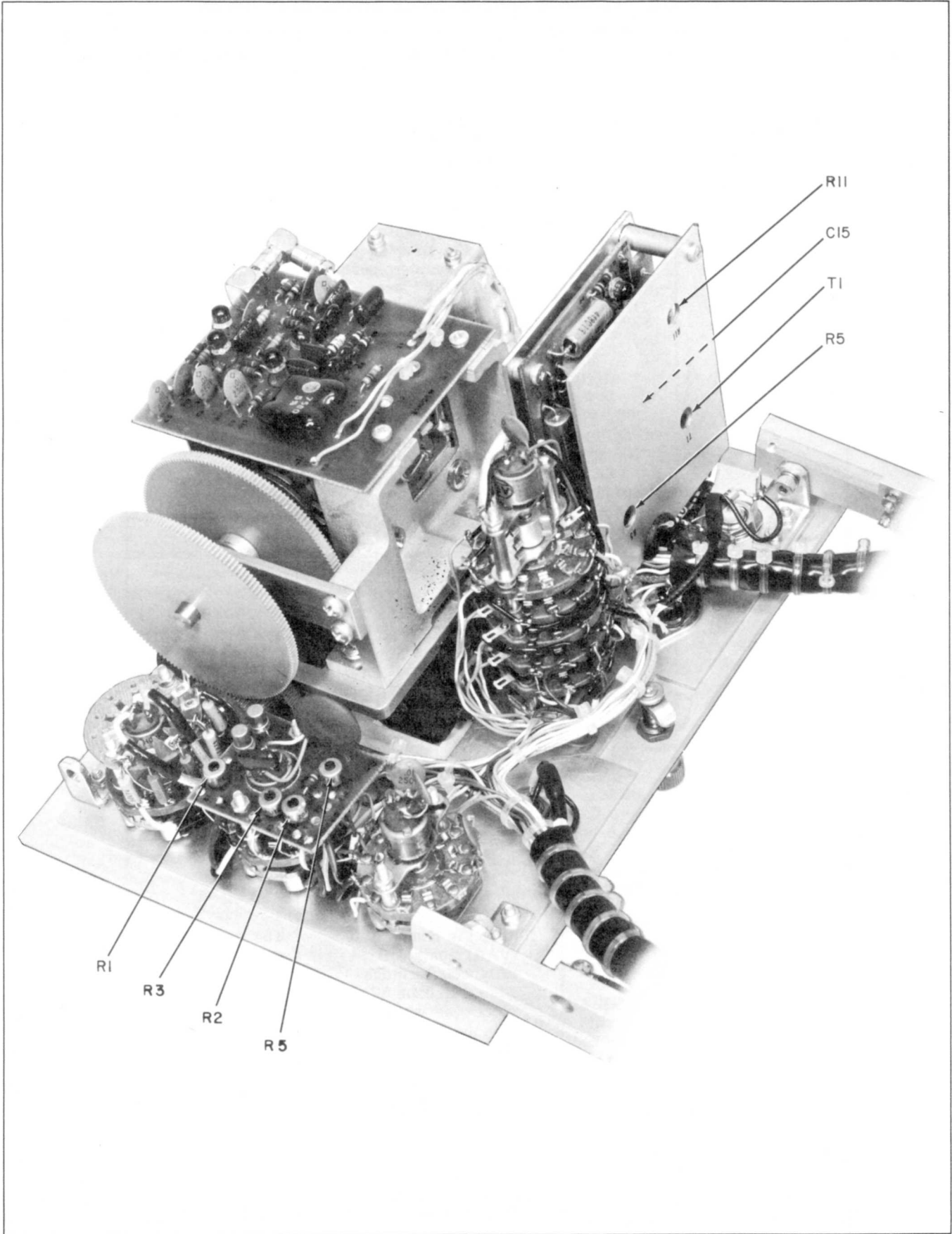

Figure 4-9. Log-Lin Module A6 and First Mixer Module A8, Adjustment Locations

TABLE 4-3. MINIMUM PERFORMANCE STANDARDS CHECKS

Step	Purpose	Procedure	Acceptable Indication
1	To check the sweep rate in the autoscan, preset, and manual modes.	<p>Set the Sweep Rate (VAR) control fully counterclockwise.</p> <p>With the stop watch measure the time required for 20 complete scans of the CRT trace.</p> <p>Set the Sweep Rate (VAR) control fully clockwise. Connect a frequency counter to X OUTPUT on Main Frame.</p> <p>Set the SWEEP RANGE switch at 0-25 MHz PRESET.</p> <p>With the stop watch measure the time required for 20 complete scans of the CRT trace.</p> <p>Set the SWEEP MODE switch at MANUAL and SWEEP RANGE switch to 50 kHz - 5 MHz.</p> <p>Rotate the Sweep Rate (VAR) control first fully counterclockwise and then fully clockwise while observing the spot on the CRT.</p>	<p>The time required should be a minimum of 20 seconds.</p> <p>The counter should indicate at least 60 Hz.</p> <p>The time required should be between 18 and 22 seconds (1 Hz <math>\pm</math>10%)</p> <p>The spot should move first to the left of the CRT and then to the right. In each of the extreme positions of the Sweep Rate (VAR) control the spot should be beyond the graticule scale.</p>
2	To check the frequency and amplitude of the markers.	<p>Set the MARKERS switch at 5 MHz.</p> <p>Connect the counter to TP1 on assembly A5.</p>	<p>The counter should read 5 MHz <math>\pm</math>1 kHz.</p>

(Cont'd)



TABLE 4-3. MINIMUM PERFORMANCE STANDARDS CHECKS (Cont'd)

Step	Purpose	Procedure	Acceptable Indication
2 (Cont'd)		<p>Set the MARKERS switch at 500 kHz.</p> <p>Connect the counter to TP2 on assembly A5.</p> <p>Set the SWEEP WIDTH control at 0.5 MHz, the MARKERS switch at 25 kHz, the MARKERS AMPLITUDE control fully clockwise, and the Sweep Rate (VAR) control fully counterclockwise.</p> <p>Set the CENTER FREQUENCY control at approximately 00.750 MHz, and then adjust the control so that the 500-kHz marker is under the -0.5 graduation on the graticule and the 1000-kHz marker is under the +0.5 graduation.</p> <p>Set the I-F ATTEN DB control at 0.</p> <p>Adjust the I-F BANDWIDTH control for optimum resolution.</p> <p>Count the number of equally spaced markers between the 500-kHz marker and the 1000-kHz marker.</p> <p>Set the CENTER FREQUENCY control at 25 MHz, the SWEEP WIDTH control at 0.1 MHz, and the I-F ATTEN DB switch at 0. Set the I-F ATTEN DB VARIABLE and MARKERS AMPLITUDE controls fully CCW and CW, respectively.</p> <p>Set the SWEEP RANGE switch at 0-25 MHz PRESET and the MARKER switch at 500 kHz.</p>	<p>The counter should read 500 kHz <math>\pm</math>100 Hz.</p> <p>The number of markers should be 19.</p> <p>With the I-F BANDWIDTH and Sweep Rate (VAR) controls set for optimum resolution, the 25-kHz markers should be visible on the CRT display.</p> <p>The 500-kHz markers should now be visible over the entire CRT display.</p>
3	To check the linearity of the preset sweep.	Set the SWEEP RANGE switch at 50 kHz - 5 MHz. The CENTER FREQUENCY control at 00.0 MHz, and	Each of the 5-MHz markers should appear at the corresponding frequency graduation of the CRT graticule within one-half division.

(Cont'd)

TABLE 4-3. MINIMUM PERFORMANCE STANDARDS CHECKS (Cont'd)

Step	Purpose	Procedure	Acceptable Indication
3 (Cont'd)		adjust the <b>FREQ CAL</b> control so that the zero pip is under the <b>CF</b> graduation on the graticule. Set the <b>SWEEP RANGE</b> switch at <b>0-25 MHz PRESET</b> and the <b>MARKERS</b> switch to <b>5 MHz</b> .	
4	To check the width and linearity of the wide-band sweep.	<p>Set the <b>SWEEP RANGE</b> switch at <b>50 kHz - 5 MHz</b> and the <b>SWEEP WIDTH</b> control at <b>5 MHz</b>.</p> <p>Set the <b>CENTER FREQUENCY</b> control at approximately <b>12.5 MHz</b> and then adjust the control to position the <b>10-MHz</b> marker under the <b>-0.5</b> graduation on the graticule.</p> <p>Set the <b>MARKERS</b> switch at <b>500 kHz</b>.</p> <p>Count the number of <b>500-kHz</b> marker spaces between the <b>-0.5</b> graduation and the <b>+0.5</b> graduation on the graticule.</p> <p>Readjust the <b>SWEEP WIDTH</b> and <b>CENTER FREQUENCY</b> controls as required to center the tenth marker (<b>15 MHz</b>), counted in the previous step, under the <b>+0.5</b> graduation while the <b>10-MHz</b> marker remains under the <b>-0.5</b> graduation.</p> <p style="text-align: center;"><b>Note</b></p> <p>If the tenth marker cannot be positioned as required, use the eighth marker instead. Now the fourth marker to the right of the <b>10-MHz</b> marker should be within <math>\pm 1/2</math> division of the <b>CF</b> graduation.</p>	<p>There should be at least <b>9</b> and no more than <b>11</b> <b>500-kHz</b> marker spacers.</p> <p>The fifth marker to the right of the <b>10 MHz</b> marker should be within <math>\pm 1/2</math> division of the <b>CF</b> graduation on the graticule.</p>

(Cont'd)

TABLE 4-3. MINIMUM PERFORMANCE STANDARDS CHECKS (Cont'd)

Step	Purpose	Procedure	Acceptable Indication
4 (Cont'd)		<p>Set the CENTER FREQUENCY control at approximately 00.750 MHz and the SWEEP WIDTH control at 0.500 MHz and adjust the CENTER FREQUENCY control so that the 500-kHz marker is under the -0.5 graduation on the graticule.</p> <p>Set the MARKERS switch at 25 kHz.</p> <p>Adjust analyzer for optimum resolution and count the number of 25-kHz marker spaces between the -0.5 graduation and the +0.5 graduation.</p> <p>Readjust the SWEEP WIDTH and CENTER FREQUENCY controls as required to center the 1-MHz marker under the +0.5 graduation while the 500-kHz marker remains under the -0.5 graduation.</p> <p>Set the CENTER FREQUENCY control at 00.500 MHz, the SWEEP WIDTH control at 0.050 MHz, and adjust the I-F BANDWIDTH control for optimum resolution.</p> <p>Adjust the CENTER FREQUENCY control so that the 500-kHz marker is under the -0.5 graduation.</p> <p>Readjust the SWEEP WIDTH and CENTER FREQUENCY controls as required to center the 550-kHz marker under the +0.5 graduation, while the 500 kHz marker remains at the -0.5 graduation.</p>	<p>There should be at least 18 and no more than 22 25-kHz marker spacers.</p> <p>The tenth marker to the right of the 500-kHz marker should be within <math>\pm 1/2</math> division of the CF graduation.</p> <p>The second marker to the right of the 500-kHz marker should be within <math>\pm 1</math> division of the +0.5 graduation.</p> <p>The center marker (525 kHz) should be within <math>\pm 1/2</math> division of the CF graduation.</p>
5	To check the calibration of the CENTER FREQUENCY dial.	Set the SWEEP WIDTH control at 0.1 kHz, the CENTER FREQUENCY control at 00.0 MHz, and set the FREQ CAL	The CENTER FREQUENCY dial should read $500 \pm 25$ kHz.

(Cont'd)

TABLE 4-3. MINIMUM PERFORMANCE STANDARDS CHECKS (Cont'd)

Step	Purpose	Procedure	Acceptable Indication
5 (Cont'd)		<p>control so that the zero pip is under the CF graduation.</p> <p>Set the MARKERS switch at 500 kHz, and readjust the CENTER FREQUENCY control so that the 500-kHz marker is under the CF graduation.</p> <p>Set the CENTER FREQUENCY control so that the 10-MHz marker is under the CF graduation.</p> <p>Set the CENTER FREQUENCY control so that the 20-MHz marker is under the CF graduation.</p>	<p>The CENTER FREQUENCY dial should read <math>10 \pm 0.5</math> MHz.</p> <p>The CENTER FREQUENCY dial should read <math>20 \pm 1</math> MHz.</p>
6	To check the width and linearity of the narrow-band sweep.	<p>Set the CENTER FREQUENCY control at 00.0 MHz, and then adjust the control to position the zero pip under the CF graduation on the graticule.</p> <p>Perform the locking procedure given in paragraph 2-44y to synchronize the wide-band oscillator with the narrow-band oscillator at the zero frequency. Set the SWEEP WIDTH control at 50 kHz.</p> <p>Connect the low-frequency signal generator to INPUT jack J6. Set the generator frequency at approximately 25 kHz and then adjust the generator frequency (and FINE TUNING NARROW BAND control if necessary) to place each 25-kHz pip (both above and below the zero pip) under the corresponding +0.5 and -0.5 graduation on the graticule.</p> <p>Set the SWEEP WIDTH control at 5 kHz.</p>	<p>The generator frequency should read 25 kHz <math>\pm 2.6</math> kHz. Also, the zero pip should be within <math>\pm 1/2</math> division of the CF graduation.</p>

(Cont'd)

TABLE 4-3. MINIMUM PERFORMANCE STANDARDS CHECKS (Cont'd)

Step	Purpose	Procedure	Acceptable Indication
6 (Cont'd)		<p>Set the generator frequency at approximately 2.5 kHz and then adjust it to position the two 2.5-kHz pips under the +0.5 and -0.5 graduations respectively.</p> <p>Set the SWEEP WIDTH control at 0.5 kHz.</p> <p>Set the generator frequency at approximately 250 Hz and then adjust it to position the two 250 Hz pips under the +0.5 and -0.5 graduations respectively. (It may be necessary to adjust the I-F BANDWIDTH control and to use a slow sweep rate to obtain the optimum resolution.) Use the smoothing filter to remove any beat signals that may appear.</p>	<p>The generator frequency should read 2.5 kHz <math>\pm</math> 350 Hz. Also the zero pip should be within <math>\pm 1/2</math> division of the CF graduation.</p> <p>The zero pip should be within <math>\pm 1/2</math> division of the CF graduation.</p>
7	To check the i-f bandwidth.	<p>Set the generator frequency at 500 Hz.</p> <p>Set SWEEP RANGE control to 50 kHz - 5 MHz. Adjust the CENTER FREQUENCY control to position the zero pip under the CF graduation on the graticule.</p> <p>Perform the locking procedure given in paragraph 2-44y to synchronize the wide-band oscillator with the narrow-band oscillator.</p> <p>Set the SWEEP RANGE switch at 0.5-kHz -50 kHz NARROW BAND</p> <p>Set the SWEEP WIDTH control to position 500-Hz pips under the -0.5 and +0.5 graduations. (This calibrates sweep width to 1 kHz or 100 Hz per division.)</p> <p>Set the FINE TUNE NARROW BAND control to place the right 500-Hz pip under the CF graduation on the graticule.</p>	

(Cont'd)



TABLE 4-3. MINIMUM PERFORMANCE STANDARDS CHECKS (Cont'd)

Step	Purpose	Procedure	Acceptable Indication
8	To check the calibration of the output against the LIN scale on the CRT.	<p>Connect the low-frequency signal generator through the 50-ohm step attenuator to INPUT jack J6. Connect the AC VTVM to monitor the output of the generator.</p> <p>Set the generator frequency at 500 kHz and its output at exactly 1 volt as measured on the VTVM.</p> <p>Set the AMPLITUDE SCALE switch at LIN.</p> <p>Adjust the external attenuator and the I-F ATTEN DB VARIABLE controls so that the signal pip deflects exactly full scale.</p> <p>Reduce the generator output so that the pip deflects exactly 9 divisions of the linear amplitude scale.</p> <p>Repeat above step for deflections of 8 divisions, 7 divisions, etc.</p>	<p>The VTVM should read <math>0.9 \pm 0.03</math> volts.</p> <p>The corresponding readings on the VTVM should be <math>0.8 \pm 0.03</math> volts, <math>0.7 \pm 0.03</math> volts, etc.</p>
9	To check the range of the I-F ATTEN DB VARIABLE control.	Set the I-F ATTEN DB VARIABLE control fully counterclockwise and adjust the generator output so that the signal pip deflects full scale.	Set the I-F ATTEN DB VARIABLE control fully clockwise. The deflection of the pip should be 3 divisions of the linear amplitude scale or less.
10	To check the overall frequency response of the module.	<p>Set the SWEEP RANGE switch at 50 kHz - 5 MHz and INPUT ATTEN DB switch at 40.</p> <p>Set the CENTER FREQUENCY control at approximately 00.050 MHz. Adjust it to position the upper sideband portion of a 50-kHz signal from the signal generator under the CF graduation.</p> <p>Perform the locking procedure given in the operator's section to synchronize the wide-band oscillator with the narrow-band oscillator.</p>	

(Cont'd)

TABLE 4-3. MINIMUM PERFORMANCE STANDARDS CHECKS (Cont'd)

Step	Purpose	Procedure	Acceptable Indication
<p>10 (Cont'd)</p>		<p>Set the SWEEP RANGE switch at 0.5 KHz - 50 KHz NARROW BAND.</p> <p>Set the SWEEP WIDTH control at 50 kHz.</p> <p>Adjust the I-F BAND-WIDTH control for optimum resolution and adjust the generator output so that the signal pip deflects 9 divisions.</p> <p>Slowly adjust the generator frequency to 1 kHz while observing the deflection of the signal pip; it will be necessary to adjust the SEARCH LOCK control slowly upward to keep the signal pip displayed on the CRT.</p> <p>Disconnect the low-frequency signal generator from the module and connect the high-frequency generator through the 50-ohm step attenuator.</p> <p>Set the generator frequency at 50 kHz.</p> <p>Set the SWEEP RANGE switch at 50 KHz - 5 MHz, the SWEEP WIDTH control at 5 MHz, and the I-F BANDWIDTH control for optimum resolution. Adjust the signal generator output level so that the signal pip deflects 9 divisions.</p> <p>Slowly adjust the generator frequency to 27.5 MHz while observing the deflection of the signal pip; it will be necessary to adjust the CENTER FREQUENCY control to keep the signal pip displayed on the CRT.</p>	<p>The generator output should be kept constant during this step. The maximum variation of the signal pip amplitude should not be more than <math>\pm 1</math> division.</p> <p>The generator output should be kept constant during this step. The maximum variation of the signal pip amplitude should not be more than <math>\pm 1</math> division.</p>

(Cont'd)



TABLE 4-3. MINIMUM PERFORMANCE STANDARDS CHECKS (Cont'd)

Step	Purpose	Procedure	Acceptable Indication
11	To check the calibration of the INPUT ATTEN DB switch.	<p>Set the generator frequency at 25 MHz and the INPUT ATTEN DB switch at 70.</p> <p>Set the SWEEP WIDTH control at approximately 0.100 MHz and the CENTER FREQUENCY control at 25 MHz.</p> <p>Set the step attenuator for zero attenuation and adjust the generator output for full scale deflection of the signal pip.</p> <p>Set the INPUT ATTEN DB switch at 60 and insert 10 dB of attenuation with the step attenuator.</p> <p>Set the generator output for exactly full scale deflection of the signal pip.</p> <p>Repeat the two previous steps for each of the remaining positions of the INPUT ATTEN DB switch. Insert 10 dB of attenuation for each 10 dB removed by the INPUT ATTEN DB switch.</p>	<p>The amplitude of the signal pip should be within <math>\pm 1/2</math> division (<math>\pm 0.5</math> dB) of full scale deflection.</p> <p>At each setting, the signal pip should be within <math>\pm 1/2</math> division of full scale.</p>
12	To check the calibration of the I-F ATTEN DB switch.	<p>Set the step attenuator for 20 dB of attenuation, the INPUT ATTEN DB switch at 50, the I-F ATTEN DB switch at 0, the I-F ATTEN DB VARIABLE control fully CCW, and adjust the generator output for full scale deflection of the signal pip.</p> <p>Set the I-F ATTEN DB switch at 5 and remove 5 dB of attenuation with the step attenuator.</p> <p>Set the generator output for exactly full scale deflection of the signal pip.</p>	<p>The amplitude of the signal pip should be within <math>\pm 0.2</math> division (<math>\pm 0.2</math> dB) of full scale deflection.</p>

(Cont'd)

TABLE 4-3. MINIMUM PERFORMANCE STANDARDS CHECKS (Cont'd)

Step	Purpose	Procedure	Acceptable Indication
12 (Cont'd)		Repeat the two previous steps for each of the remaining positions of the I-F ATTEN DB switch. Remove 5 dB of attenuation for each 5 dB inserted by the I-F ATTEN DB switch.	At each setting, the signal pip should be within $\pm 0.2$ division of full scale.
13	To measure the minimum signal that can be detected by the module (S+N=2N)	<p>Set the INPUT ATTEN DB and I-F ATTEN DB switches at 0, the I-F ATTEN DB VARIABLE control fully CCW, and insert 50 dB of attenuation with the step attenuator.</p> <p>Set the I-F BANDWIDTH control fully clockwise and the Sweep Rate (VAR) control for a 20-Hz sweep.</p> <p>Set the AMPLITUDE SCALE switch at LOG.</p> <p>Connect the high frequency VTVM to monitor the generator output.</p> <p>Adjust the generator output until the signal pip is barely visible (S+N=2N).</p>	The VTVM should read less than 10 millivolts.
14	To check the calibration of the output with the LOG scale of the CRT.	<p>Set the generator frequency at 12.5 MHz and the generator output at 300 microvolts.</p> <p>Set the step attenuator for zero attenuation. Set the INPUT ATTEN DB switch to 0.</p> <p>Set the CENTER FREQUENCY control at approximately 12.5 MHz and then adjust it to position the signal pip under the CF graduation on the graticule.</p>	The peak of the signal pip should be at $0 \pm 1$ dB of the log scale of the graticule.

(Cont'd)

TABLE 4-3. MINIMUM PERFORMANCE STANDARDS CHECKS (Cont'd)

Step	Purpose	Procedure	Acceptable Indication
14 (Cont'd)		With the step attenuator, reduce the level of the signal input in 5-dB steps noting the amplitude of the signal pip after each step.	The pip amplitude should agree with the input attenuation within $\pm 1$ dB from 0 to -30dB, and within $\pm 2$ dB from -30 to -40dB.
15	To check the magnitude of the harmonic and inter-modulation distortion products.	<p>Disconnect the signal generator.</p> <p>Set the CENTER FREQUENCY control at 00.0 MHz and perform the locking procedure given in paragraph 2-44y to synchronize the wide-band oscillator with the narrow-band oscillator.</p> <p>Set the SWEEP RANGE switch at 0.5 KHz - 50 KHz.</p> <p>Set the SWEEP WIDTH control at 20 kHz and adjust the I-F BANDWIDTH and Sweep Speed (VAR) controls for optimum resolution.</p> <p>Slowly adjust the SEARCH/LOCK control downward to position the zero pip under the -0.5 graduation on the CRT graticule.</p> <p>Connect the two-tone test generator through the 100:1 taper attenuator to INPUT jack J6.</p> <p>Set the generator frequencies at 7 kHz and 9 kHz and adjust the outputs for equal amplitude.</p> <p>Adjust the amplitude of the composite output of the generator to obtain pip amplitudes of 0 dB on the CRT and then increase the generator input by 10 dB.</p>	All harmonic and inter-modulation distortion products should lie below the -40 dB graduation of the graticule.

(Cont'd)

TABLE 4-3. MINIMUM PERFORMANCE STANDARDS CHECKS (Cont'd)

Step	Purpose	Procedure	Acceptable Indication
15 (Cont'd)		Slowly adjust the SWEEP WIDTH control for 50 kHz while also adjusting the SEARCH/LOCK control slowly downward to keep the zero pip under the -0.5 graduation. Watch for higher order components of the input signals.	All higher order components should lie below the -40 dB graduation.

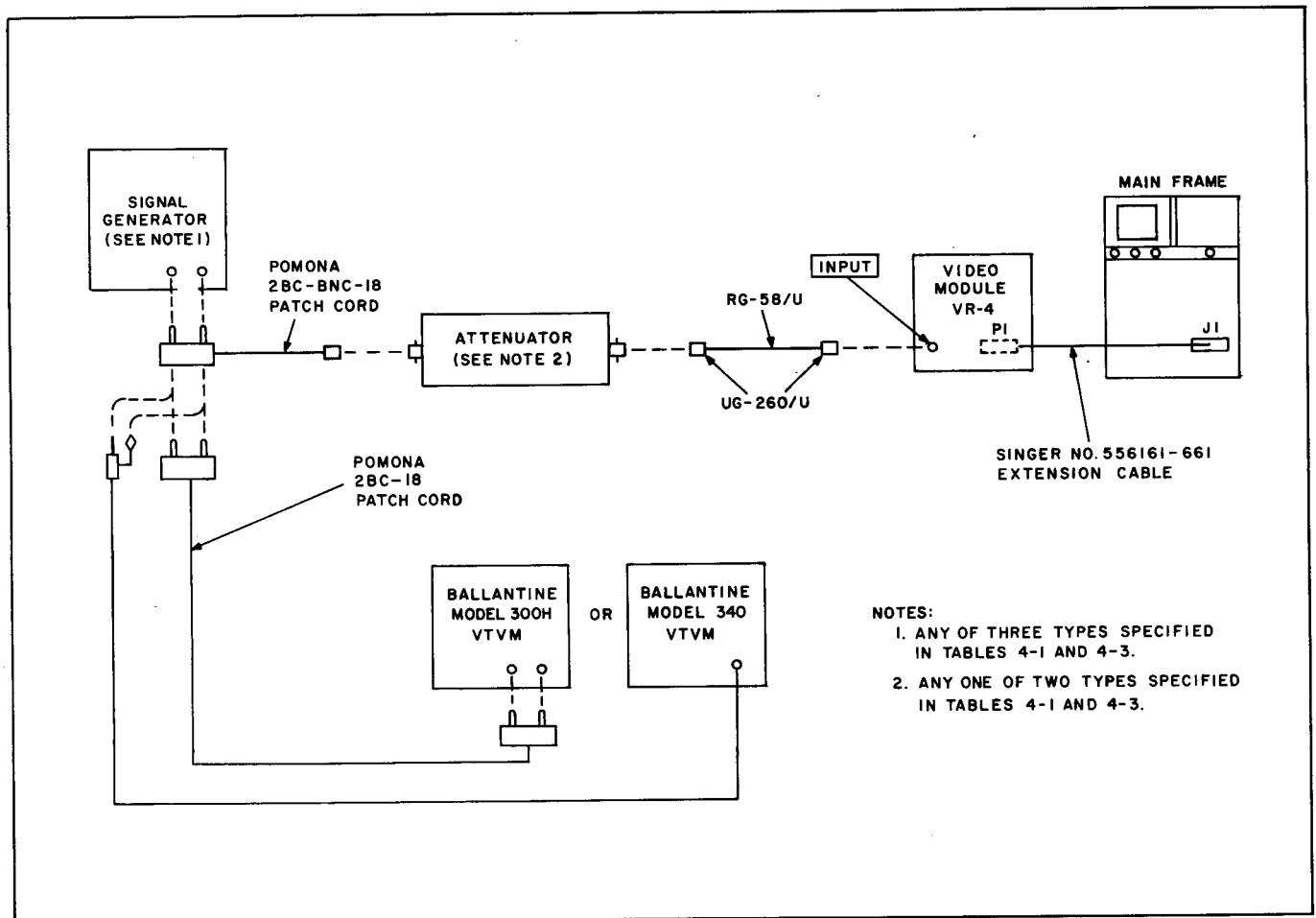

Figure 4-10. Minimum Performance Standards, Equipment Setup

c. Connect a signal generator to the INPUT jack. Set the generator frequency at 100 kHz.

d. Set the SWEEP WIDTH control at approximately 0.100 MHz and the CENTER FREQUENCY control at 0.100 MHz. Set the MARKERS switch at OFF.

e. Set the INPUT ATTEN DB switch at 0. Adjust the signal generator output level for exactly full scale deflection on the CRT.

f. While observing the CRT, set the INPUT ATTEN DB switch at 10, 20, 30 and then 40, and note the signal pip is at the -10, -20, -30 and -40 LOG DB graduation ( $\pm 1/2$  division), respectively, of the CRT graticule. If not, adjust the VERT and VERTICAL SIZE screwdriver adjustments on the Model MF-2 Main Frame or the VERT. POS control and V SIZE screwdriver adjustment on the Model MF-5 Main Frame until this result is obtained.

#### 4-15. ALIGNMENT PROCEDURES.

4-16. Paragraphs 4-19 through 4-28 give a complete alignment procedure for the VR-4 module. Each of the procedures starts with the operator's controls in the preliminary position given in paragraph 4-18 so that any procedure can be performed independent of the rest. It should be stressed that these procedures should be performed only when a minimum performance standard check is not satisfactory or a component has been replaced in an adjustable circuit.

4-17. The alignment procedures given assume that the main frame in which the VR-4 Module is used is operating within its specifications. Therefore, the minimum performance checks given in the instruction manual for the main frame should be performed (also any required alignment) prior to starting the alignment of the VR-4 Module.

4-18. PRELIMINARY CONTROL SETTINGS. The preliminary control settings for each of the alignment procedures are given in the following tabulation.

#### Note

Allow the equipment (both module and Main Frame) to warm up for 30 minutes before commencing with the alignment.

<u>Control</u>	<u>Position</u>
a. On the VR-4 Module.	
INPUT ATTEN DB switch	70
CENTER FREQUENCY control	00.0 MHz
I-F ATTEN DB switch	0

<u>Control</u>	<u>Position</u>
I-F ATTEN DB VARIABLE control	Fully counterclockwise. (0 DB)
MARKERS switch	OFF
SWEEP WIDTH control	5.0 MHz
AMPLITUDE SCALE switch	LOG
SMOOTHING FILTER control	Fully counterclockwise.
0Hz BALANCE controls	Fully clockwise
SWEEP RANGE switch	0-25 MHz PRESET
I-F BANDWIDTH control	Fully clockwise
SWEEP MODE switch	AUTO SCAN
Sweep Rate (VAR)	Fully clockwise
INPUT switch	50
All others	Any

#### b. On the Main Frame

All controls As required to produce a clear sharp trace on the CRT that is centered horizontally and coincides with the baseline on the graticule.

#### 4-19. HORIZONTAL AND VERTICAL SWEEP POSITION ADJUSTMENT.

a. Set the operator's controls at the preliminary settings given in paragraph 4-18.

b. Set the SWEEP MODE switch at MANUAL and the SWEEP RANGE switch at 50 kHz - 5 MHz.

c. Set the RCA VTVM to read on the +15 vdc range and connect it between pin 12 of P1 (positive) and ground.

d. Set the Sweep Rate (VAR) control so that the VTVM reads +2.3 vdc.

e. Set the horizontal positioning control on the Main Frame to position the dot on the CRT under the -0.5 graduation on the graticule.

f. Set the Sweep Rate (VAR) control so that the VTVM reads +8.3 VDC.

g. Set the horizontal size control of the main frame to position the dot under the -0.5 graduation on the CRT graticule.

Section IV  
Maintenance

- h. Repeat steps d through g until no further improvement is obtained.
- i. Set the SWEEP MODE switch at AUTO SCAN and the Sweep Rate (VAR) control fully clockwise.
- j. Switch the AMPLITUDE SCALE switch back and forth between LIN and LOG and note the shift in the position of the base line. Continue switching and adjust OUTPUT DC LEVEL A2R25 for minimum base-line shift. Reposition the baseline on the bottom graduation of the graticule by adjusting the VERT positioning control on the front of the main frame.
- k. Set the SWEEP RANGE SWITCH AT 0-25 MHz PRESET.
- l. Set SAWTOOTH LIMIT A1R58 so that the left end of the CRT trace is 1/8 inch to the left of the -0.5 graduation.

4-20. MARKER FREQUENCY ADJUSTMENT.

- a. Set the operator's controls at the preliminary settings given in paragraph 4-18.
- b. Connect the counter to A5TP1.
- c. Set the MARKERS switch at 5 MHz and the MARKERS AMPLITUDE control fully clockwise. The frequency counter should read 5 MHz  $\pm$  1 kHz.
- d. Set the MARKERS switch at 500 kHz.
- e. Connect the counter to A5TP2.
- f. Adjust MARKER LEVEL A5R8 so that the counter reads 500 kHz  $\pm$  100 Hz.
- g. Set the MARKERS switch to 25 kHz.
- h. Connect the counter to A5TP3. The frequency counter should read 25 kHz  $\pm$  5 Hz.

4-21. PRELIMINARY OSCILLATOR AND I-F ALIGNMENT.

**Note**

This alignment is only a preliminary step. The procedures given in paragraph 4-23 must also be performed before the oscillator and i-f alignment is complete.

- a. Set the operator's controls at the preliminary settings given in paragraph 4-18.
- b. Set the MARKERS switch at 500 kHz, the MARKERS AMPLITUDE control fully clockwise, the SWEEP RANGE switch at 50 kHz - 5 MHz, and the AMPLITUDE SCALE switch at LIN.

- c. Unplug A3P1 from A3J1 and look at the CRT. If markers are present, skip steps d through u and proceed with step v. If markers are not present, continue with step d.
- d. Connect the high frequency AC VTVM between A3TP1 and ground.
- e. Set A3C19 for maximum reading on the VTVM.
- f. Look at the CRT. If markers are present, skip steps g through u and proceed with step v. If markers are not present, continue with step g.
- g. Set the MARKERS switch at OFF.
- h. Connect the high-frequency signal generator through the 0.01 microfarad capacitor to pin 2 of J2. Set the generator frequency at 2.7 MHz and the generator output for a small deflection of the base line.
- i. Set A2C5 and A2C10, in that order, for maximum deflection of the base line.
- j. Repeat step i until no further improvement is obtained.
- k. Connect the signal generator through the capacitor to pin 1 of J4.
- l. Set A4C19, A4C23, and A4C26, in that order, for maximum deflection of the base line.
- m. Repeat step l until no further improvement is obtained.
- n. Set the MARKERS switch at 500 kHz and look at the CRT. If markers are present, skip steps p through u and proceed with step v. If markers are not present, proceed with step p.
- o. Set the MARKERS switch at OFF.
- p. Set the signal generator frequency to 32.238 MHz. Connect the signal generator through the 0.01 microfarad capacitor to pin 4 of J3 and adjust the generator output for a small deflection of the base line.
- q. Set A3C15, A3T1, and A3T2, in that order, for maximum deflection of the base line.
- r. Repeat step q until no further improvement is obtained.
- s. Connect the signal generator (no capacitor) to INPUT jack J6 and adjust the generator output for a small deflection of the base line.
- t. Set A8T1 for maximum deflection of the base line. Disconnect the signal generator.
- u. Set the MARKERS switch at 500 kHz and verify that markers appear on the CRT.
- v. Set the MARKERS switch at 5 MHz, the CENTER FREQUENCY control at approximately

5 MHz (so that the 5-MHz marker can be seen), and the **MARKERS AMPLITUDE** control for a small deflection of the 5-MHz marker.

w. Set A3C19, A2C5, A2C10, A3C15, A3T1, A3T2, A8T1, A4C19, A4C23, and A4C26, in that order, for maximum deflection of the 5-MHz marker.

x. Repeat step w until no further improvement is obtained.

#### 4-22. 2.7 MHz CRYSTAL FILTER ADJUSTMENT.

a. Set the operator's controls at the preliminary settings given in paragraph 4-18.

b. Set the **SWEEP RANGE** switch at 50 KHz -5 MHz and the **FREQ CAL** control at the midpoint of its range.

c. Set **ZERO FREQ ADJ A1R3** to position the zero pip under the CF graduation on the graticule.

d. Slowly reduce the setting of the **SWEEP WIDTH** control to 0.050 MHz while adjusting **ZERO FREQ ADJ A1R3** as required to keep the zero pip under the CF graduation.

e. Set the **SWEEP WIDTH** control at 5 MHz.

f. Set **DC BAL ADJ A1R17** to position the zero pip under the CF graduation.

g. Set the **CENTER FREQUENCY** control at 25 MHz.

h. Set the **MARKERS** switch at 5 MHz.

i. Set **25 MHz ADJ A1R7** to position the 25-MHz marker under the CF graduation.

j. Set the **CENTER FREQUENCY** control at approximately 5 MHz and adjust it to position the 5-MHz marker under the CF graduation.

k. Perform the locking procedure given in paragraph 2-44y to synchronize the wide-band oscillator with the narrow band oscillator.

l. Set the **SWEEP RANGE** switch at 0.5 KHz -50 KHz **NARROW BAND**, the **MARKERS AMPLITUDE** control fully clockwise, the **Sweep Rate (VAR)** control fully counterclockwise, the **AMPLITUDE** scale switch to **LIN** and the **FINE TUNING NARROW BAND** control to position the 5-MHz marker under the CF graduation.

m. Remove crystal A4Y1 from its socket.

n. Set the **I-F BANDWIDTH** control fully clockwise, the **Sweep Rate (VAR)** control fully CW, and the **MARKERS AMPLITUDE** control for full scale deflection of the marker.

o. Set A4C13 for the best symmetry of the display and A4C14 for maximum bandwidth. Adjust the

**MARKERS AMPLITUDE** control as required to maintain full scale deflection.

p. Repeat step o until no further improvement is obtained.

q. Set the **SWEEP WIDTH** control so that the leading edge of the 5-MHz marker crosses the -0.5 frequency graduation at the -20 dB amplitude graduation and the trailing edge crosses the +0.5 frequency graduation at the 5 amplitude graduation. Readjust A4C13, if necessary, to obtain this display.

r. Return the **SWEEP WIDTH** control to 50 kHz. Slowly rotate the **I-F BANDWIDTH** control counterclockwise and observe that the amplitude of the center of the marker decreases in a straight line down the CF graduation.

s. Plug in A4Y1 and remove A4Y2.

t. Repeat steps n through r adjusting A4C2 and A4C3 instead of A4C13 and A4C14.

u. Plug in A4Y2.

v. Return the **I-F BANDWIDTH** control to fully CW. Set the **MARKERS AMPLITUDE** control for full scale deflection and repeat step q. Trim up A4C3 and/or A4C14, if necessary.

#### 4-23. FINAL OSCILLATOR AND I-F ALIGNMENT.

a. Set the operator's controls at the preliminary settings given in paragraph 4-18.

b. Set the **SWEEP RANGE** switch at 50 kHz -5 MHz, the **SWEEP WIDTH** control at 5 MHz, the **CENTER FREQUENCY** control at 5 MHz, and the **MARKERS** switch at 5 MHz.

c. Adjust the **CENTER FREQUENCY** control to position the 5 MHz marker under the CF graduation.

d. Repeat steps k and l of paragraph 4-22.

e. Set the **SWEEP WIDTH** control at 0.5 kHz. Set the **AMPLITUDE SCALE** switch to **LIN**.

f. Set the **MARKERS AMPLITUDE** control for a small deflection of the 5-MHz marker. Adjust the **FINE TUNING NARROW BAND** control for maximum deflection of the base line.

g. Set A3C19, A2C5, A2C10, A3C15, A3T1, A3T2, A8T1, A4C19, A4C23, and A4C26, in that order, for maximum deflection of the base line.

#### 4-24. 26.838 MHz TRAP ADJUSTMENT.

a. Set the operator's controls at the preliminary settings given in paragraph 4-18.

Section IV  
Maintenance

b. Set the SWEEP RANGE switch to 0.5 kHz-50 kHz NARROW BAND, the SWEEP WIDTH to 0.5 kHz, and the AMPLITUDE SCALE switch to LIN.

c. Connect the high-frequency signal generator through the 0.01 microfarad capacitor to pin 4 of J3.

d. Set the generator frequency at 26.838 MHz.

e. Set the generator output for full scale deflection of the signal pin. Readjust generator frequency for maximum deflection of the baseline.

f. Reconnect A3P1 to A3J1. Set A3C1 for minimum deflection of the baseline, adjusting the generator output as required to maintain a display.

4-25. PHASE SPLITTER, BALANCE, AND HARMONIC DISTORTION ADJUSTMENTS.

a. Set the operator's controls at the preliminary settings given in paragraph 4-18.

b. Connect the low-frequency signal generator to INPUT jack J6.

c. Set the frequency of the generator at 1 kHz and the output at 5 millivolts. Set the wave analyzer to measure the fundamental signal.

d. Disconnect A8P1 from A8J1. Connect the wave analyzer to A8TP1 and measure the level of the signal.

e. Repeat step d at A8TP2.

f. Adjust A8R11 to obtain equal signal levels at both test points.

g. Set the wave analyzer to measure the second harmonic signal.

h. Repeat steps d and e.

i. Set A8R5 for minimum second harmonic level at both test points.

j. Repeat steps c through i until no further improvement is obtained.

k. Adjust the 0 Hz BALANCE controls until the zero pip is minimum amplitude. (Use IF ATTEN DB control as required.)

l. Adjust A8C15 for minimum zero pip amplitude.

m. Repeat steps k and l until no further improvement is obtained.

4-26. SWEEP RATE ADJUSTMENT.

a. Set the operator's controls at the preliminary settings given in paragraph 4-18.

b. With the stop watch measure the time required for 10 complete scans of the CRT trace.

c. Set A6R5 so that the time required for 10 complete scans is 10 seconds.

4-27. AMPLITUDE ADJUSTMENT.

a. Set the operator's controls at the preliminary settings given in paragraph 4-18.

b. Set the CENTER FREQUENCY control at 12.5 MHz, the FINE TUNING NARROW BAND control to the center of its range, SWEEP RANGE switch at 50 kHz - 5 MHz, and the INPUT ATTEN DB switch to 0.

c. Connect the high-frequency signal generator through the step attenuator to INPUT jack J6. Set step attenuator to 0 dB.

d. Set the generator frequency at 12.5 MHz and the generator output at 300 microvolts.

e. Adjust the CENTER FREQUENCY control to position the signal under the CF graduation on the graticule.

f. Set the SWEEP RANGE switch at SEARCH/ LOCK and lock the wideband oscillator to the narrow-band oscillator (paragraph 2-44y) and then set the SWEEP RANGE switch at 0.5 kHz to 50 kHz.

g. Adjust the FINE TUNING NARROW BAND control to position the signal under the CF graduation on the graticule.

h. Set the SWEEP WIDTH control at 10 kHz and adjust the Sweep Rate (VAR) and I-F BANDWIDTH controls for optimum resolution of the signal.

i. Set A6R3 so that the amplitude of the signal is 0 dB.

j. Set the step attenuator for 20 dB of attenuation.

k. Adjust I-F GAIN A2R13 so that the signal amplitude is -20 dB.

l. Set the step attenuator for 0 dB attenuation and repeat step i.

m. Repeat steps j, k, and l, until no further improvement is obtained.

n. Set the AMPLITUDE SCALE switch at LIN and set the step attenuator for 20 dB of attenuation.

o. Set A6R2 so that the signal amplitude on the linear scale is 10.

p. Insert another 6 dB with the step attenuator (a total now of 26 dB).

q. Set A6R1 so that the signal amplitude on the linear scale is 5.

r. Remove 6 dB of attenuation with the step attenuator and repeat step o.



s. Repeat steps p, q, and r, until no further improvement is obtained.

#### 4-28. SHAPING CIRCUIT ADJUSTMENT.

a. Set the operator's controls at the preliminary settings given in paragraph 4-18.

b. Set the MARKERS switch at 5 MHz, the CENTER FREQUENCY control at 5 MHz, the SWEEP RANGE switch to 50 KHz-5 MHz, and the I-F ATTEN DB switch at 10.

c. Adjust the FREQ CAL control through its entire range and note the total excursion of the 5 MHz marker on the CRT.

d. Set the FREQ CAL control so that the zero pip is positioned in the middle of its excursion as noted in the previous step.

e. Set the RANGE switch to 0-25 MHz PRESET. The 25-MHz marker should be under the +0.5 graduation of the graticule. If not, select values for A5C56 and A5C57 to position the 25-MHz marker as near the +0.5 graduation as possible. (Equal values should be used for A5C56 and A5C57; the permissible range of values is from 22 to 39 picofarads.) Adjust A5R76 to position the 0-MHz marker under the -0.5 graduation on the graticule.

f. Set A1R46, A1R48, A1R50, A1R52, and A1R54 so that the 20, 15, 10, 5, and 0-MHz markers are under the second, fourth, sixth, eighth, and tenth graduations from the +0.5 graduation on the graticule, respectively.

g. Repeat step f until no further improvement is obtained.

h. Set the SWEEP RANGE switch at 50 KHz - 5 MHz and set the CENTER FREQUENCY control to position the 10-MHz marker under the -0.5 graduation on the graticule.

i. Set SWEEP WIDTH ADJ A1R18 to position the 15-MHz marker under the +0.5 graduation on the graticule, while continuously adjusting CENTER FREQUENCY control to keep the 10-MHz marker under the -0.5 graduation.

j. Set the CENTER FREQUENCY control at 00.0 MHz and the SWEEP WIDTH control at 0.05 MHz

k. Set ZERO FREQ ADJ A1R3 to position the zero pip under the CF graduation on the graticule.

l. Set the SWEEP WIDTH control at 5 MHz.

m. Set DC BAL A1R17 to position the zero pip under the CF graduation on the graticule.

n. Set the CENTER FREQUENCY control at 25 MHz.

o. Set 25-MHz ADJ A1R7 to position the 25-MHz marker under the CF graduation on the graticule.

p. Set the MARKERS switch at 500 kHz.

q. Set A1R31 so that the markers above and below the 25-MHz marker are equally spaced.

r. Adjust 25-MHz ADJ A1R7 to reposition the 25-MHz marker under the CF graduation on the graticule.

s. Adjust the CENTER FREQUENCY control to position the 25-MHz marker under the +0.5 graduation of the CRT graticule.

t. Adjust A1R46 to position the 20-MHz marker under the -0.5 graduation on the graticule.

#### Note

The five following steps are a general procedure which is to be performed in conjunction with table 4-4. This procedure must be performed four separate times as indicated by the table using the data given in the table.

u. Set the CENTER FREQUENCY control to position the right marker under the +0.5 graduation.

v. Set the adjustment to position the left marker under the -0.5 graduation.

w. Set the linearity adjustment so that the markers either side of the CF graduation on the graticule are evenly spaced.

x. Set the right marker control to reposition the right marker under the +0.5 graduation.

y. Set the left marker control to reposition the left marker under the -0.5 graduation.

z. Repeat steps u through y for the three remaining sets of conditions given in the table. If difficulty is experienced on the achieving dial tracking at low frequencies, set the SWEEP WIDTH control to 0.5 kHz, the MARKERS switch at 500 kHz, and the CENTER FREQUENCY control to 00.5 MHz. Adjust A1R42 to position the 500-kHz marker under the CF graduation on the graticule. Set the CENTER FREQUENCY control to 00.0 MHz and adjust A1R43 to position the zero pip under the CF graduation. Repeat these adjustments until no further improvement can be obtained. Recheck linearity of other markers throughout the frequency range.

aa. Set the SWEEP RANGE switch at 0-25 MHz PRESET and the MARKERS switch at 5 MHz. Check all of the markers for correct positioning with respect to the graduations on the graticule. All markers should be correctly positioned within  $\pm 1/4$  graduation. If the markers are correctly positioned, proceed with step ab. If the markers are not correctly positioned, repeat steps e through z.

ab. Set the SWEEP RANGE switch at 50 KHz - 5 MHz and the CENTER FREQUENCY control at 10 MHz. Position the CENTER FREQUENCY control so that the 10-MHz marker is under the CF graduation on the graticule.

ac. Perform the locking procedure given in paragraph 2-44y to synchronize the wide-band oscillator with the narrow-band oscillator and then set the SWEEP RANGE switch at 0.5-50 KHz NARROW BAND.

ad. Set the FINE TUNING NARROW BAND control to position the 10-MHz marker under the CF graduation on the graticule.

Section IV  
Maintenance

ae. Set the Sweep Rate (VAR) control and the I-F BANDWIDTH control for optimum resolution of the signal.

af. Set the MARKERS switch at 25 kHz and the SWEEP WIDTH control at 50 kHz.

ag. Set 50-kHz SWEEP WIDTH ADJ A1R55 to position the 25-kHz markers on either side of the CF graduation under the +0.5 and -0.5 graduation on the graticule.

**4-29. SYSTEMATIC TROUBLE LOCALIZATION.**

4-30. The key to the systematic localization of troubles within the VR-4 module is understanding the theory of operation of the module. A thorough knowledge of the theory permits the location of any defective component by a series of tests using the operator's controls and a minimum amount of test equipment.

4-31. To demonstrate a logical method of troubleshooting, three problems have been assumed and a procedure for locating the source of each problem has been devised. In each case, the information that can be derived from the detailed block diagram in Section III and from the operation of the module, is used to localize the trouble before any test equipment is employed. The three problems are:

- a. No trace on the CRT.
- b. No 25-kHz markers.

c. Normal CRT trace, but low noise and signal.

d. Normal CRT trace with normal noise, but no signal, zero pip, or markers. Table 4-5 gives the procedures for troubleshooting these problems.

**4-32. TYPICAL VOLTAGE MEASUREMENTS.**

4-33. Voltage measurements for each of the transistor stages in the VR-4 module are given in table 4-6. These values were obtained by setting the operator's controls at the positions given below and measuring the voltages with the RCA VTVM listed in table 4-6.

<u>Control</u>	<u>Position</u>
INPUT ATTEN DB switch	0
I-F ATTEN DB switch	0
I-F ATTEN DB VARIABLE control	Fully CW
MARKERS switch	25 KHz
AMPLITUDE SCALE switch	LOG
SWEEP RANGE switch	0-25 MHz PRESET
I-F BANDWIDTH control	Mid-position
INPUT switch	50
All others	Any

TABLE 4-4. SHAPING CIRCUIT ADJUSTMENT TABULATION

Procedure	Right Marker	Left Marker	Left Marker Control	Linearity Adjustment	Right Marker Control
1	20MHz	15MHz	A1R48	A1R39	A1R46
2	15MHz	10MHz	A1R50	A1R40	A1R48
3	10MHz	5MHz	A1R52	A1R41	A1R50
4	5MHz	0MHz	A1R54	A1R42 and A1R43	A1R52

TABLE 4-5. SYSTEMATIC TROUBLE LOCALIZATION

No.	Symptom	Test Procedure	If Indication Is Normal	If Indication Is Abnormal
A	No trace on CRT.	<p>a. Check for the presence of a sawtooth waveform on pin 12 of P1.</p> <p>b. Check the presence of all power supply inputs at P1.</p>	<p>a. Troubleshoot the main frame as described in its instruction manual</p> <p>b. Troubleshoot sawtooth generator A1Q3, A1Q4, and A1Q5 using the voltage measurements given in table 4-6.</p>	<p>a. Go to b.</p> <p>b. Troubleshoot the main frame as described in its instruction manual</p>

(Cont'd)

TABLE 4-5. SYSTEMATIC TROUBLE LOCALIZATION (Cont'd)

No.	Symptom	Test Procedure	If Indication Is Normal	If Indication Is Abnormal
B	<p>No 25-kHz markers (The 5-MHz and 500-kHz markers are present.)</p>	<p>a. Check for the presence of a 250-kHz square wave at the emitter follower A5Q13.</p> <p>b. Check for the presence of a 25-kHz square wave at the base of amplifier A5Q12.</p> <p>c. Check for the presence of a 250-kHz square wave at the base of emitter follower A5Q13.</p>	<p>a. Go to b.</p> <p>b. Replace A5Q12.</p> <p>c. Replace A5Q13.</p>	<p>a. Go to c.</p> <p>b. Replace A5A1.</p> <p>c. Troubleshoot binary divider A5Q14/A5Q15.</p>
C	<p>Low noise and signal on CRT.</p> <p><b>Note</b></p> <p>Almost all of the noise generated by the VR-4 is amplified in the A2 and A4 modules; noise that is generated in the earlier stages receives its largest amplification in these modules. Thus, the problem could be caused by a low gain stage in either of the modules.</p>	<p>a. Rotate VERT. POS. control R207 and observe that baseline moves.</p> <p>b. Set the AMPLITUDE SCALE switch at LOG. Switch the I-F ATTEN DB switch from one position to the next and check the CRT to determine that the signal attenuation produced is 5 dB per step. If no signal or noise appears, go to c.</p> <p><b>Note</b></p> <p>For steps c thru f it is necessary to slightly rock frequency of generator to obtain true baseline rise.</p>	<p>a. Go to b.</p> <p>b. Troubleshoot the A2 module using the voltage measurements given in table 4-6.</p>	<p>a. Check V11, VERT. POS. control R207, and VER. ADJ. control R211.</p> <p>b. Troubleshoot the A4 module using the voltage measurements given in Table 4-6.</p>

(Cont'd)

TABLE 4-5. SYSTEMATIC TROUBLE LOCALIZATION (Cont'd)

No.	Symptom	Test Procedure	If Indication Is Normal	If Indication Is Abnormal
C (Cont'd)		<p>c. Connect a 2.7-MHz, 150-microvolt signal to pin 2 of A2P1. Observe that baseline rises to approximately full scale.</p> <p>d. Connect a 2.7-MHz, 0.6-millivolt signal to pin 1 of A4P1. Observe that baseline rises to approximately full scale.</p> <p>e. Connect a 32.238-MHz, 200-microvolt signal through a 0.02 picofarad capacitor to pin 4 A3P1. Observe that baseline rises approximately full scale.</p> <p>f. Connect a 10-MHz, 100-microvolt (rms) signal to P4 (at output of input attenuator). Set the CENTER FREQUENCY control at 10.00 MHz and the MARKERS switch to OFF. Observe that the signal is approximately full scale.</p>	<p>c. Go to d.</p> <p>d. Go to e.</p> <p>e. Go to f.</p> <p>f. Check input attenuator A9.</p>	<p>c. Troubleshoot the A2 module using the voltage measurements given in table 4-6.</p> <p>d. Troubleshoot the A4 module using the voltage measurements given in table 4-6.</p> <p>e. Troubleshoot the A3 module using the voltage measurements given in table 4-6.</p> <p>f. Troubleshoot the A8 module using the voltage measurements given in table 4-6.</p>
D	<p>Normal noise on CRT, but no signal, zero pip, or markers.</p> <p><b>Note</b></p> <p>The fact that the CRT trace and noise are normal indicates that the sawtooth generator and the A2 and A4 modules are functioning properly. Thus, the defective component must be in or before the 2.7-MHz mixer. Note, however, that the A8Q1 and A8Q2 stages need not be checked, if the zero pip is not present.</p>	<p>a. Check the operation of the wide-band local oscillator at L. O. OUT jack J7.</p>	<p>a. Go to b.</p>	<p>a. Go to c.</p>

(Cont'd)

TABLE 4-5. SYSTEMATIC TROUBLE LOCALIZATION (Cont'd)

No.	Symptom	Test Procedure	If Indication Is Normal	If Indication Is Abnormal
D (Cont'd)		<p>b. Inject a 5-MHz signal into pin 4 of J3 through a 0.01 microfarad capacitor, and check for deflection of the CRT baseline.</p> <p>c. Set the SWEEP RANGE switch at 0-25 MHz and check for the presence of a sawtooth waveform at pin 9 of J5 with an oscilloscope.</p> <p>d. Repeat step c with the SWEEP RANGE switch set at 50 KHz - 5 MHz.</p>	<p>b. Troubleshoot the balanced mixer A8Q3/A8Q4 using the voltage measurements given in table 4-6.</p> <p>c. Troubleshoot wide-band local oscillator A5Q19/A5Q20 and buffer amplifier A5Q18 using the voltage measurements given in table 4-6.</p> <p>d. Troubleshoot emitter follower A1Q8 and A1Q7 using the voltage measurements given in table 4-6.</p>	<p>b. Troubleshoot the A3 module using the voltage measurements given in table 4-6.</p> <p>c. Go to d.</p> <p>d. Troubleshoot complimentary dc amplifier A1Q11/A1Q12 and sawtooth shaping amplifier Q1Q13 using its voltage measurements given in table 4-6.</p>

TABLE 4-6. VOLTAGE MEASUREMENTS (See Note 1)

Module	Stage	Emitter	Base	Collector
A1	Q1	6.7	7.2	18.0
	Q2	6.2	6.7	10.5
	Q3	5.8	17.3 (Note 2)	0
	Q4	5.2	5.8	17.5
	Q5	18.2	17.5	11.0
	Q6	14.0	14.6	18.2
	Q7	7.8	7.2 (Note 4)	-9.0
	Q8	0.6	1.2 (Note 3)	18.2
	Q9	7.8	7.2	-0.9
	Q10	14.6	15.3	18.2
	Q11	7.4	7.8	17.5
	Q12	18.2	17.5	9.2
	Q13	4.8	5.4	6.5
A2	Q1	-4.7	-5.0	-10.8
	Q2	-1.6	-1.8	-10.8
	Q3	-1.6	-1.8	-10.8
	Q4	-4.8	-5.2	-10.8
	Q5	0.78	0.13	-5.3
	Q6	-5.8	-6.0	-10.8
	Q7	-5.5	-5.3	0
	Q8	0.08	0.8	22.0

(Cont'd)

TABLE 4-6. VOLTAGE MEASUREMENTS (See Note 1) (Cont'd)

Module	Stage	Emitter	Base	Collector
A3	Q1	10.4	10.1	0
	Q2	10.4	10.1	0
	Q3	11.5	11.3	0
	Q4	1.5	2.1	13.9
A4	Q1	-0.6	-1.2	-8.1
	Q2	0.6	0	-8.4
	Q3	-2.4	-3.1	-6.7
	Q4	-2.4	-3.1	-5.8
	Q5	-0.6	-1.2	-8.1
	Q6	0.6	0	-8.4
	Q7	21.3 (Note 5)	2.0 (Note 5)	21.5 (Note 5)
	Q8	22.0	21.5 (Note 5)	22.0 (Note 5)
	Q9	-6.7	-6.0	0
	Q10	-5.3	-6.0	-11.8
A5	Q1	5.6	6.1	7.8
	Q2	5.6	6.1	7.8
	Q3	0	0.4	2.5
	Q4	0	0.4	2.5
	Q5	-0.4	-0.6	3.9
	Q6	0.3	0	8.8
	Q7	11.3	11.7	13.8
	Q8	11.3	11.7	13.8
	Q9	0	0.4	2.5
	Q10	0	0.4	2.5
	Q11	0	0	-7.2
	Q12	0	-0.1	-9.6
	Q13	20	2.5	5.0
	Q14	0	0.4	2.5
	Q15	0	0.4	2.5
	Q16	-19.0	-17.5	-1.2
	Q17	-3.3	-3.6	-17.5
	Q18	1.2	1.7	9.6
	Q19	4.8	5.2	12.1
	Q20	4.8	5.2	12.1
A7 (Note 7)	Q1	-2.5	-2.2	-0.65
	Q2	-7.9	-7.1	-4.2
	Q3	-7.4	-7.0	-3.7
	Q4	-2.1	-3.7	0
A8	Q1	-0.7	0	8.7
	Q2	-0.7	0	8.7
	Q3	1.4	1.6	8.0
	Q4	1.4	1.6	8.0

**Notes**

1. All voltages taken with respect to chassis ground with an RCA WV-98C VTVM.
2. Determined by SAWTOOTH LIMIT ADJ. A1R58.
3. Determined by 5 MHz SWEEP WIDTH ADJ. A1R18 and DC BAL ADJ A1R17.
4. Determined by DC BAL ADJ. A1R17.
5. Determined by DC balance voltages for A1Q1 and A1Q2 taken in 0.5 KHz - 50 KHz NARROW BAND position of SWEEP RANGE control.
6. I-F BANDWIDTH control fully CCW.
7. SWEEP RANGE control in SEARCH LOCK position, SEARCH LOCK thumbwheel in maximum upward position.

**SECTION V**  
**SCHEMATIC DIAGRAMS**

Section V  
Schematic Diagrams

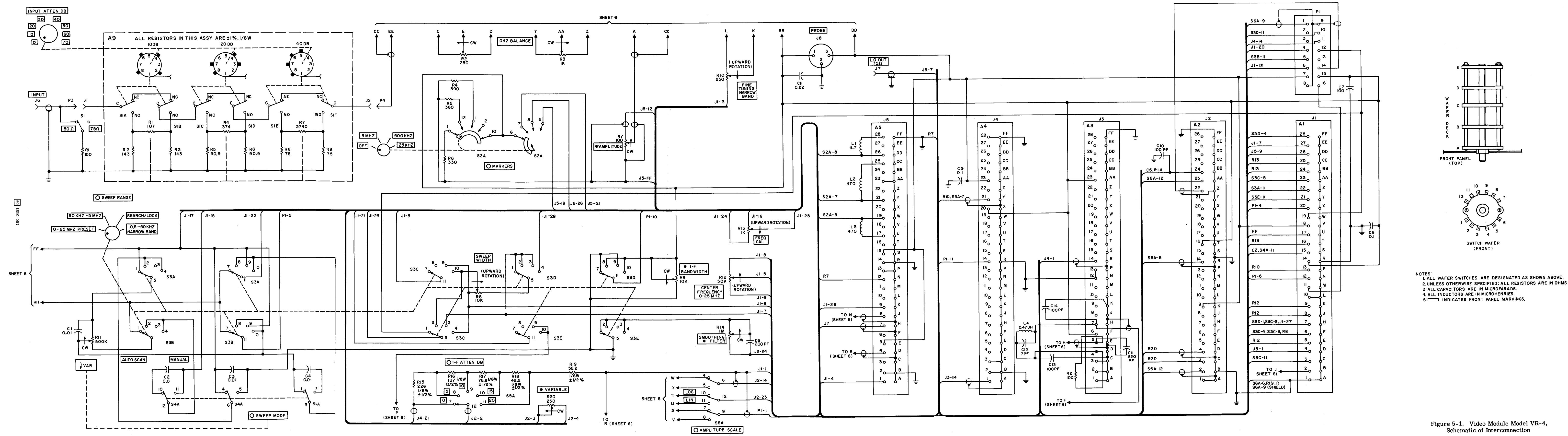
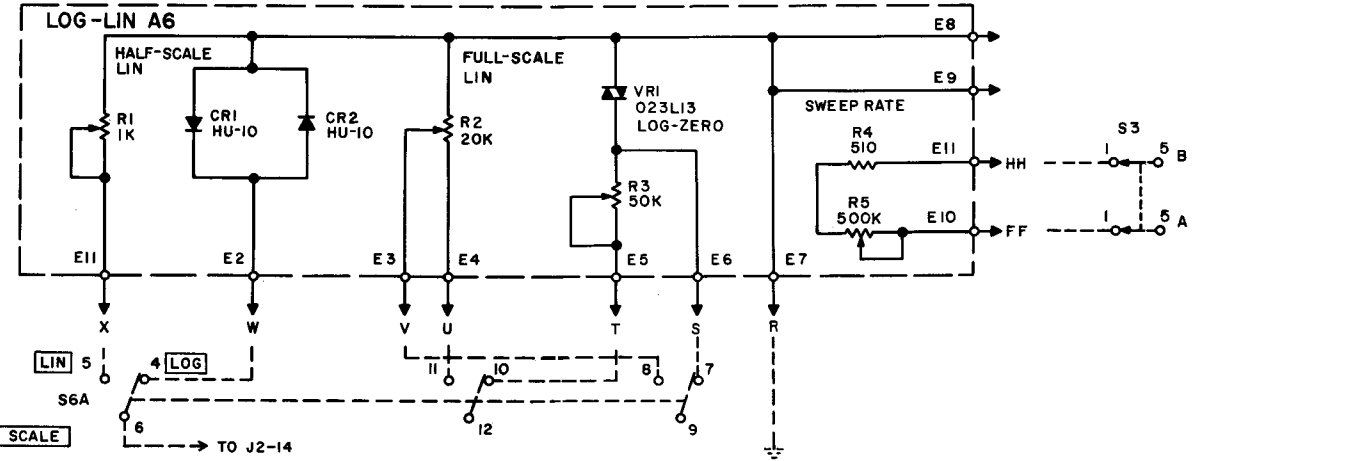
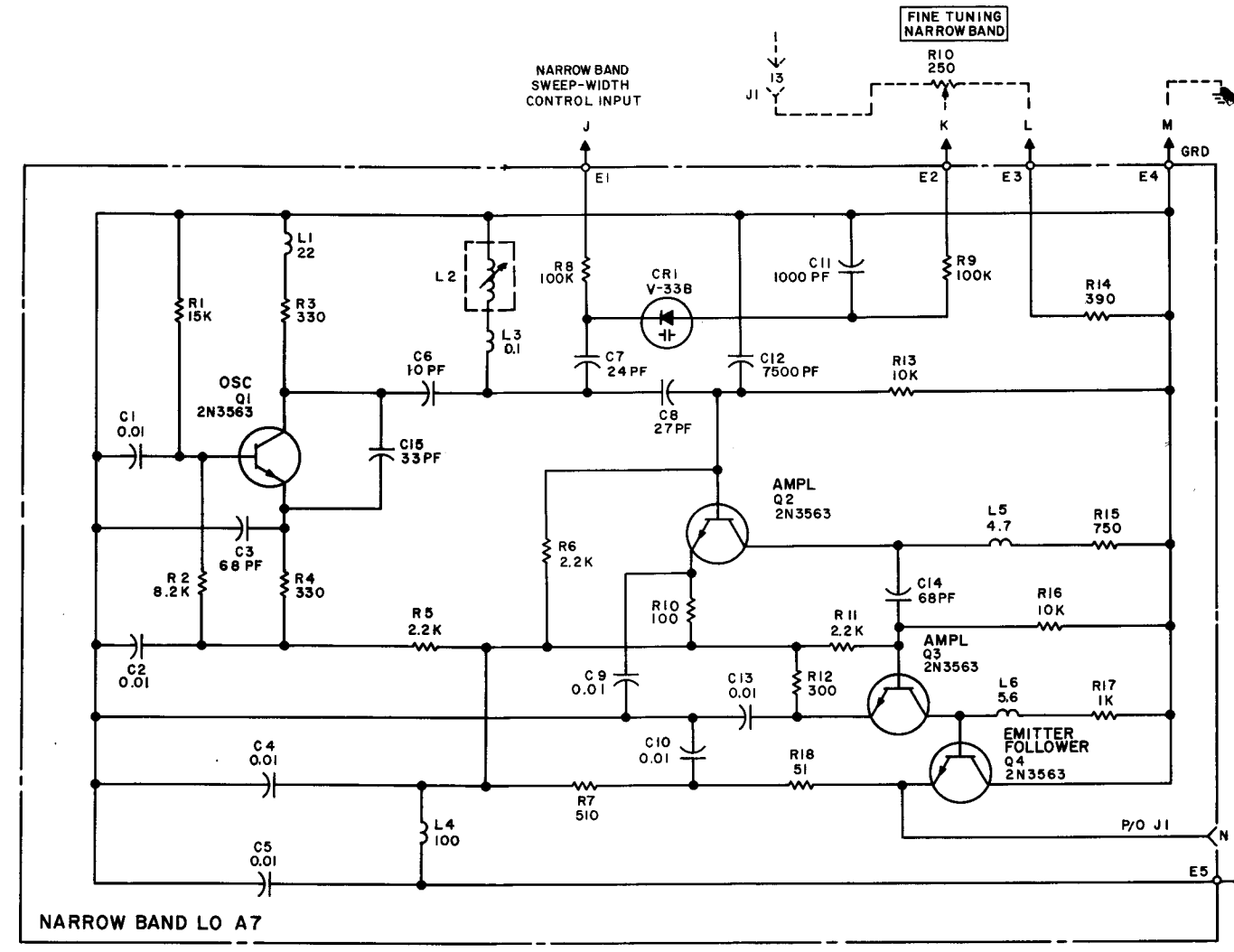
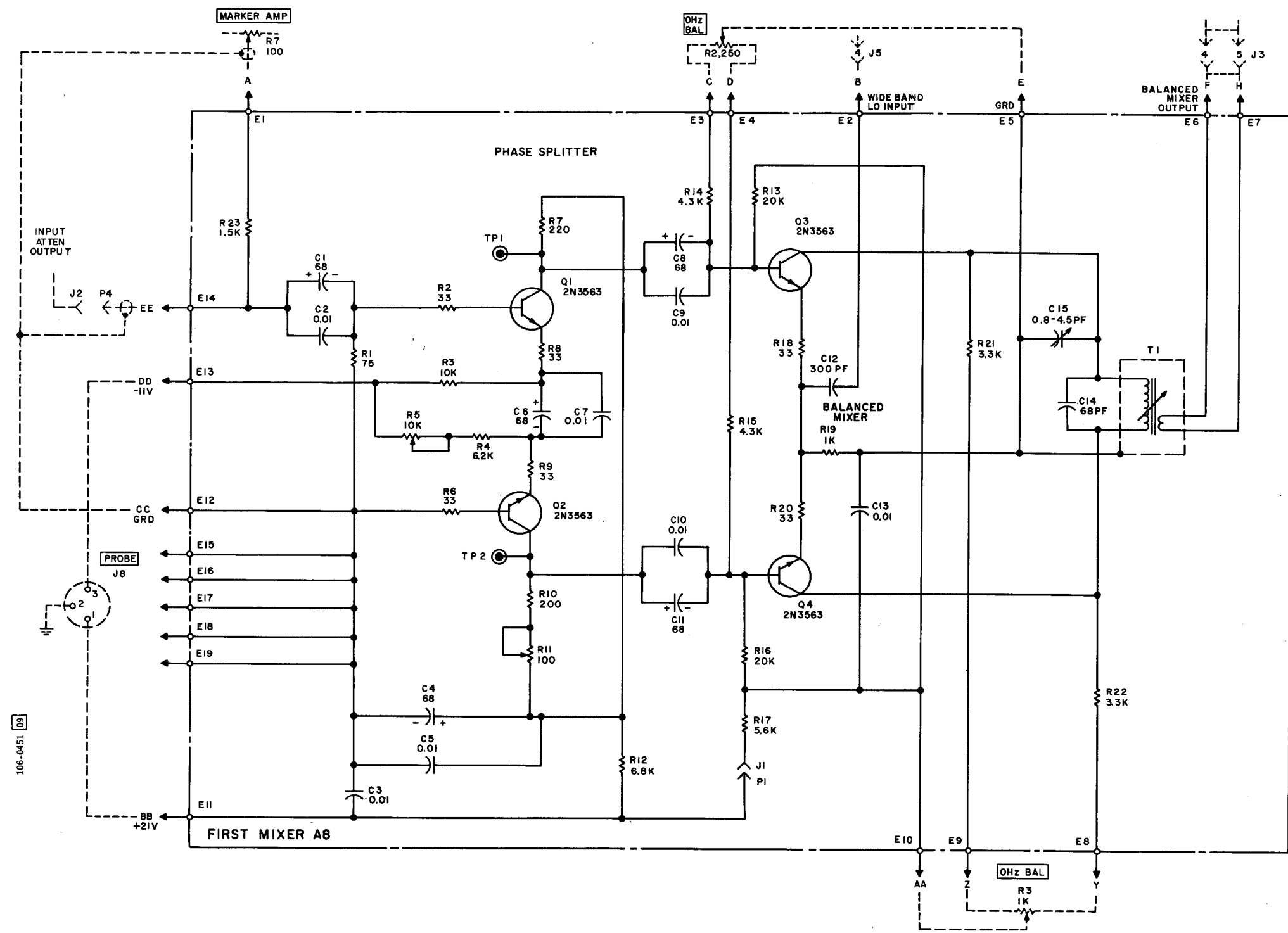

Figure 5-1. Video Module Model VR-4,  
Schematic of Interconnection





- NOTES:  
1. UNLESS OTHERWISE SPECIFIED: ALL RESISTORS ARE IN OHMS, 1/4W, ±5%.  
2. ALL CAPACITORS ARE IN MICROFARADS.  
3. ALL INDUCTORS ARE IN MICROHENRIES.

Figure 5-2. Log/Lin Assembly A6, Narrow Band Local Oscillator Assembly A7, and First Mixer Assembly A8, Schematic Diagram

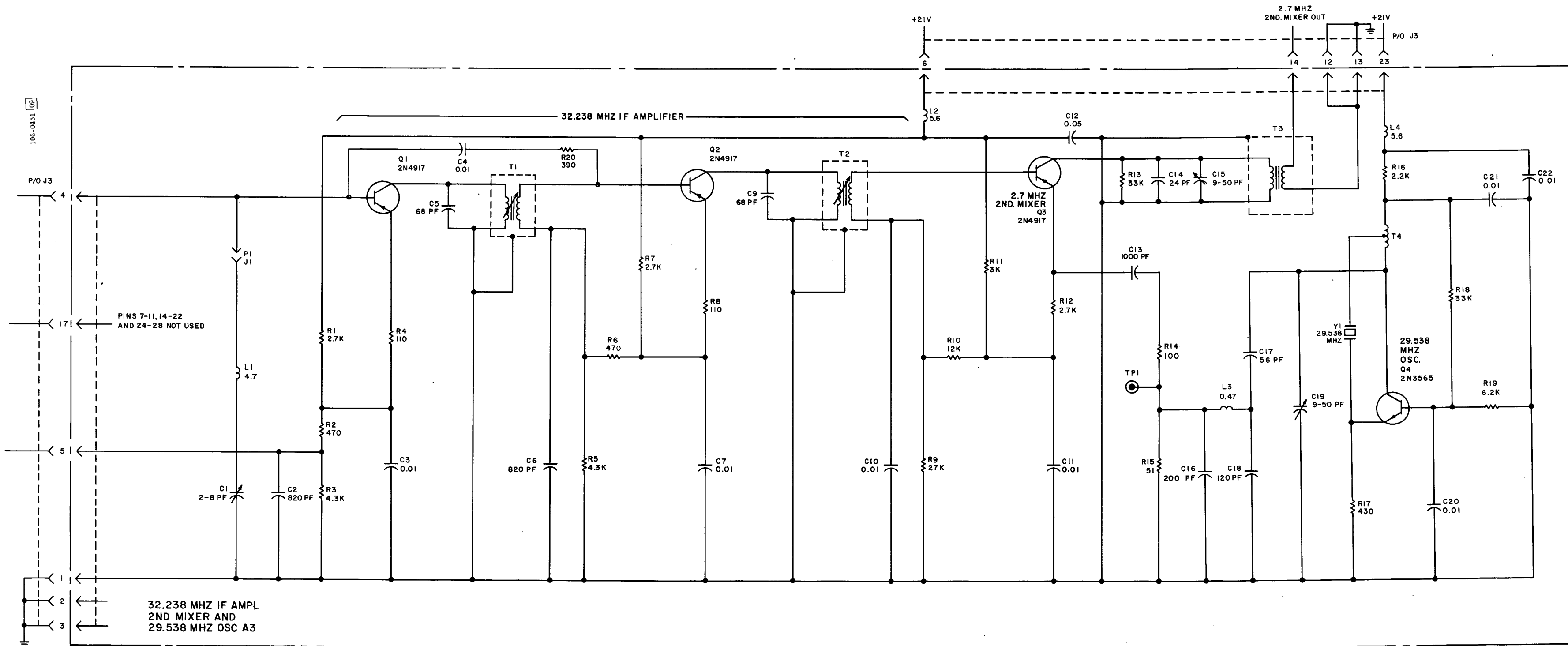

- NOTES:
1. UNLESS OTHERWISE SPECIFIED, ALL RESISTORS ARE IN OHMS, 1/4 W, ±5%.
  2. ALL CAPACITORS ARE IN MICROFARADS.
  3. ALL INDUCTORS ARE IN MICROHENRIES.

Figure 5-3. 32.238 MHz I-f Amplifier/Second Mixer/29.538 MHz Oscillator Assembly A3,

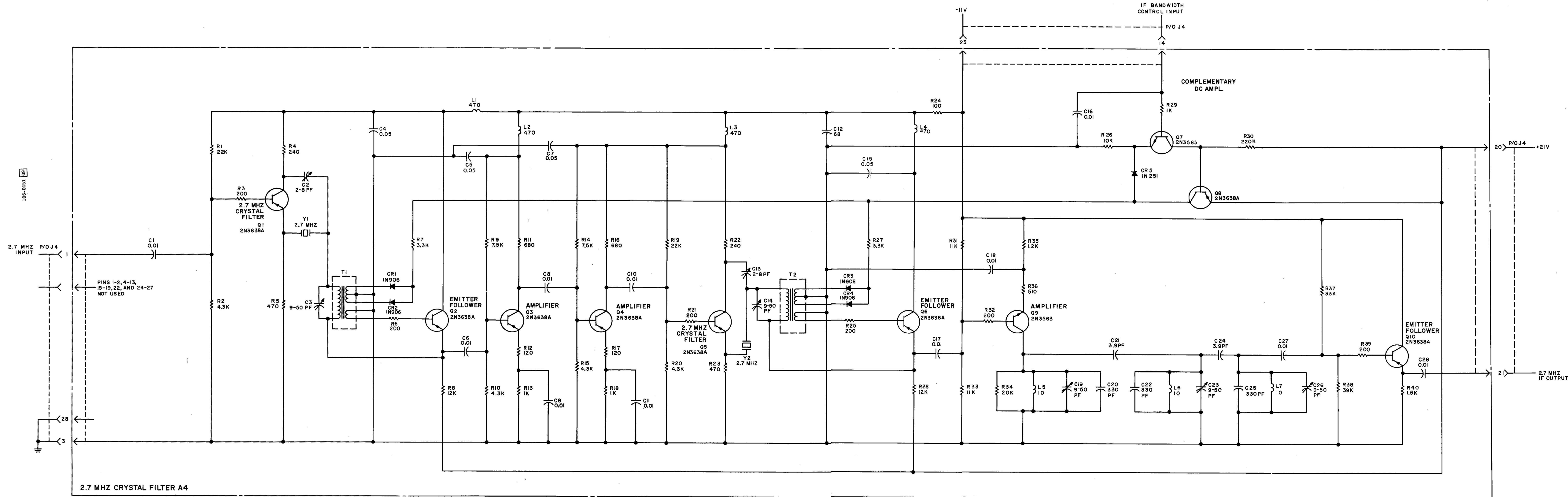

- NOTES:  
1. UNLESS OTHERWISE SPECIFIED,  
ALL RESISTORS ARE IN OHMS, 1/4 W, ±5%.  
2. ALL CAPACITORS ARE IN MICROFARADS.  
3. ALL INDUCTORS ARE IN MICROHENRIES.

Figure 5-4. 2.7 MHz Crystal Filter Assembly A4,

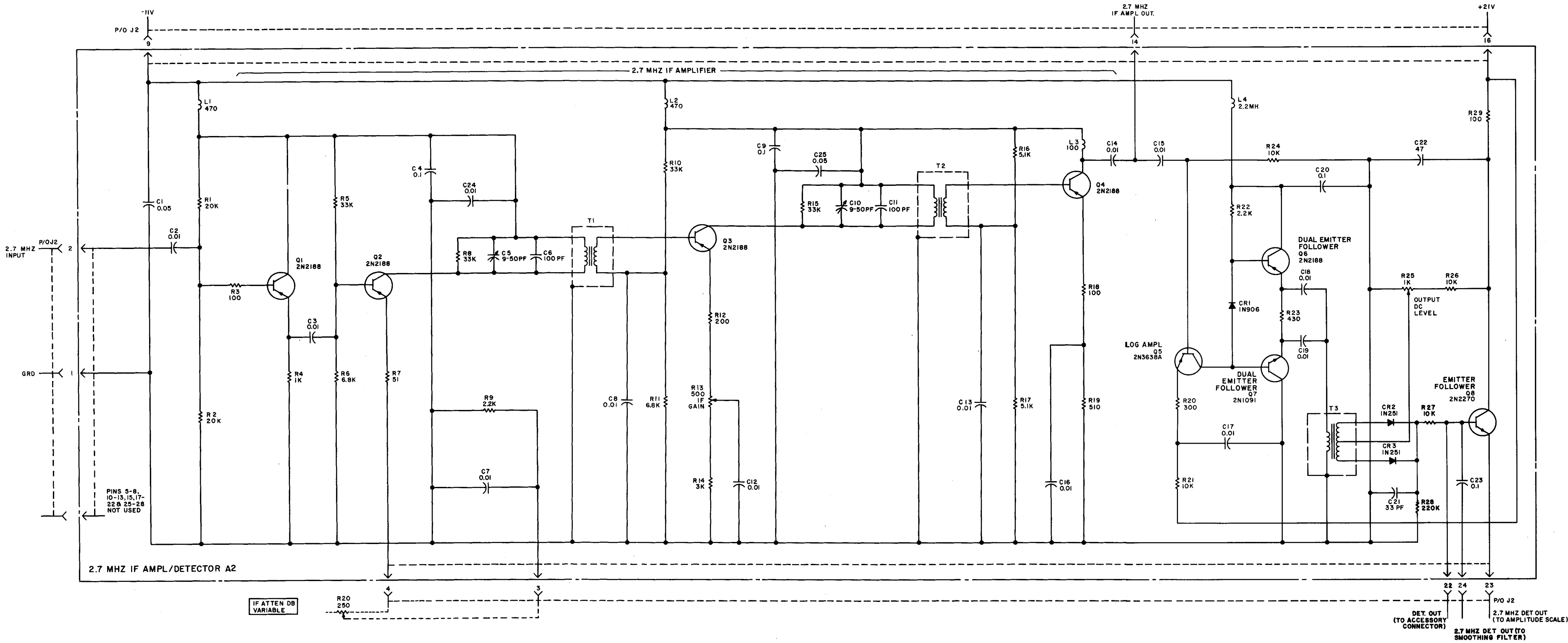

NOTES:  
1. UNLESS OTHERWISE SPECIFIED:  
ALL RESISTORS ARE IN OHMS, 1/4W, 5%.  
2. ALL CAPACITORS ARE IN MICROFARADS.  
3. ALL INDUCTORS ARE IN MICROHENRIES.

Figure 5-5. I-f Amplifier/Detector Assembly A2, Schematic Diagram

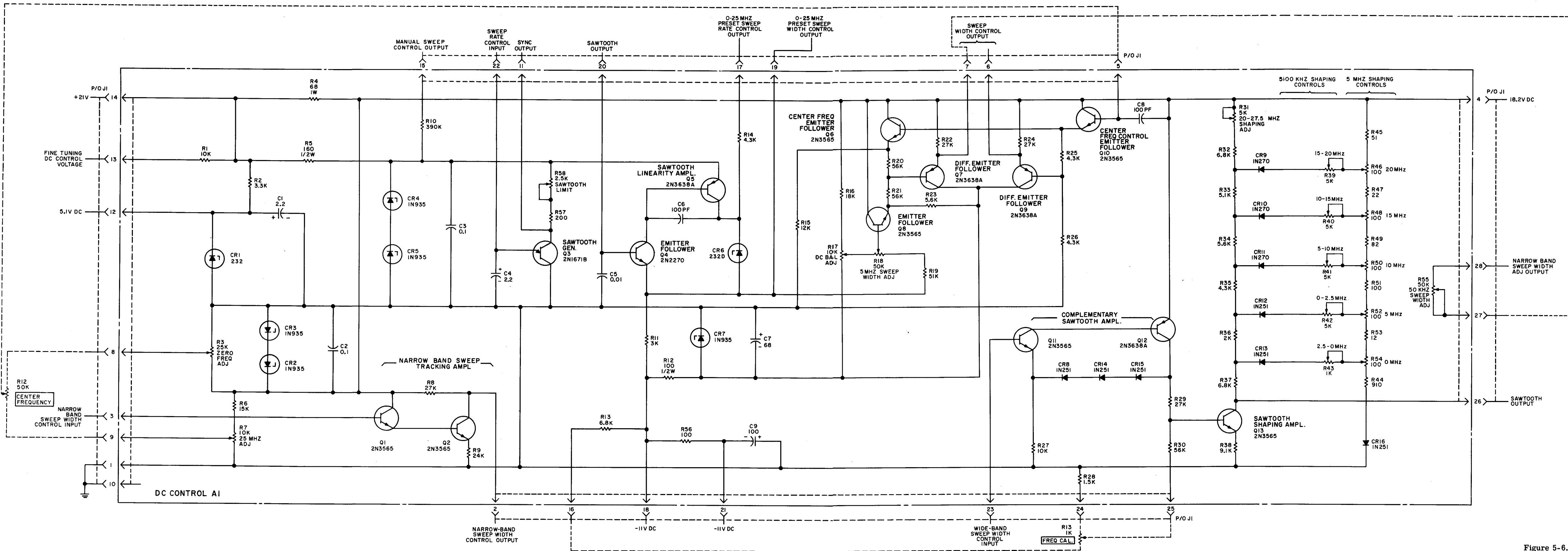

NOTES:  
1. UNLESS OTHERWISE SPECIFIED:  
ALL RESISTORS ARE IN OHMS, 1/4W, ±5%.  
2. ALL CAPACITORS ARE IN MICROFARADS.

Figure 5-6. DC Control Assembly A1,  
Schematic Diagram

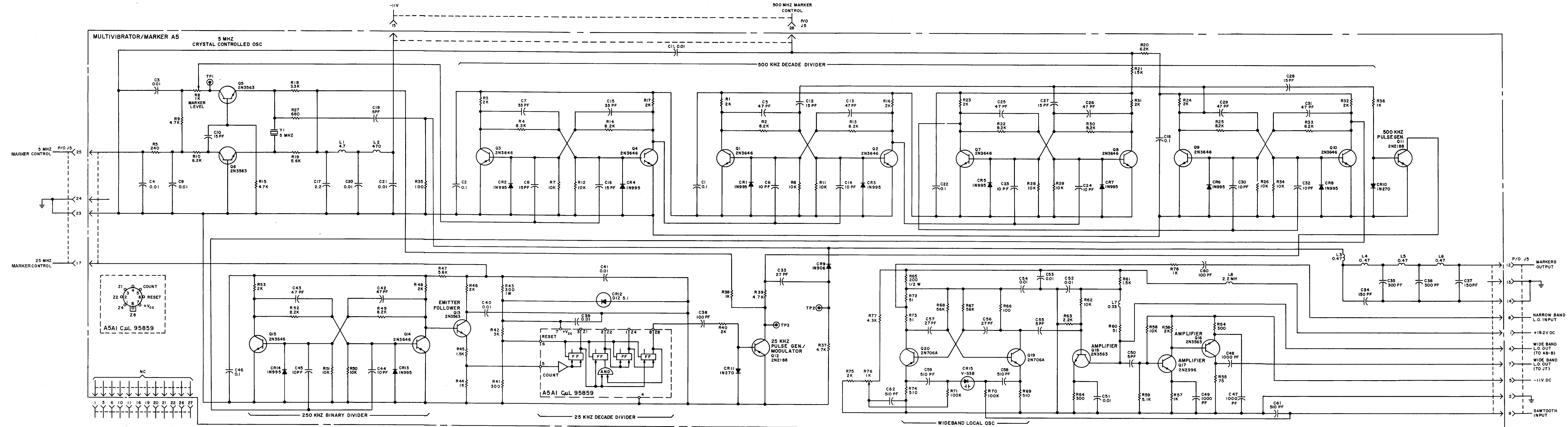

NOTES:  
1. UNLESS OTHERWISE SPECIFIED, ALL RESISTORS ARE IN OHMS, 1/4 W, ±5%.  
2. ALL CAPACITORS ARE IN MICROFARADS.  
3. ALL INDUCTORS ARE IN MICROHENRIES.

Figure 5-7. Multivibrator/Marker Assembly A5, Schematic Diagram

## SECTION VI

### PARTS LIST

#### 6-1. INTRODUCTION.

6-2. This parts list section includes all pertinent data necessary to locate, identify, and procure additional parts for the equipment. Parts are listed alpha-numerically by reference symbol and include all replaceable items such as electronic, electro-mechanical, and mechanical parts of the equipment. In some cases, values, ratings and manufacturer sources shown are nominal and variations may be found. Satisfactory replacement may be made with either the listed component or an exact replacement of the part(s) removed from the equipment.

#### 6-3. ORDERING INFORMATION.

6-4. The following instructions will aid in ordering parts from the Parts List, table 6-2:

- a. Address all inquiries or orders to:

CUSTOMER SERVICE  
Department 500-1  
The Singer Company  
Metrics Division  
915 Pembroke Street  
Bridgeport, Conn., 06608

- b. Include the following information:

- 1) Model and Serial Number of instrument.
- 2) Singer Part Number.
- 3) Reference Symbol Number.
- 4) Description (as shown on list).

#### 6-5. HOW TO USE THE PARTS LIST.

6-6. Paragraphs 6-7 through 6-11 describe the use and meaning of the five columns included in the parts list, table 6-2 (see figure 6-1).

6-7. REF SYMBOL COLUMN. The Ref Symbol Column (1, figure 6-1) contains an alpha-numerical listing of parts as they appear on equipment chassis, illustration, or schematic. The reference designation identifies the parts as to their component function in the instrument.

6-8. DESCRIPTION COLUMN. The Description Column (2, figure 6-1) contains the identification of component parts including all pertinent specifications and Singer Part Number. When the description column is used for a part which is identical to a part which has already been described; SAME AS (3) is used along with the reference symbol of the previously used part. In these instances, columns 3, 4, 5 are left blank. When the description column is used for a reference symbol for which no part exists; NOT USED (4) is placed in the column. In these instances, columns 3, 4, 5, are left blank.

6-9. MANUFACTURER'S PART NUMBER COLUMN. The Manufacturer's Part Number column (5, figure 6-1) contains the part number as designated by the manufacturer of the part.

6-10. MFR'S CODE COLUMN. The Mfr's Code column (6, figure 6-1) references the manufacturer by an assigned code number as listed in Federal Supply Code Handbook H4-2. For manufacturers not listed in H4-2, a letter code will be assigned. Table 6-1 includes the manufacturer and his code designation.

6-11. MAINT QTY COLUMN. The Maint Qty column, (7, figure 6-1) contains the number of additional components recommended to keep the equipment at an optimum performance level. The recommended number of components in the Maint Qty column is based on 2000 hours of equipment operation.

TABLE 6-2. PARTS LIST

REF SYMBOL	DESCRIPTION	MANUFACTURER'S PART NUMBER	MFR'S CODE	MAINT QTY
C109	CAPACITOR, ELECTROLYTIC, 20uf, MINUS 10PCT, PLUS 75PCT, 600V SINGER PART NO. 150-5004-001	D40690	56289	2
C110 THRU C124	SAME AS C709			
C125	NOT USED			
DS1	LAMP, INCANDESCENT SINGER PART NO. 160-6001-004	327	08806	2
R1 THRU R14	RESISTOR, FIXED COMP., 750 ohms, PORM 5 PCT, 1/2W SINGER PART NO. 151-1003-751J	EB7515	01121	1

Figure 6-1. Parts List Sample

TABLE 6-1. MANUFACTURER'S CODE

Number	Name	Number	Name
01121	Allen-Bradley Co. Milwaukee, Wis.	07263	Fairchild Camera and Instrument Corp. Semiconductor Division Mountain View, Calif.
01281	TRW Semiconductors, Inc. Lawndale, Calif.	07933	Raytheon Co. Semiconductor Operation Components Division Mountain View, Calif.
01295	Texas Instruments, Inc. Semiconductor-Components Division Dallas, Texas	11453	Precision Connectors, Inc. Jamaica, N. Y.
02335	Fairchild Controls Corp. Hicksville, Long Island, N. Y.	12060	Diodes, Inc. Chatsworth, Calif.
02660	Amphenol-Borg Electronics Corp. Maywood, Ill.	12126	Kidco, Inc. Medford, N. J.
02777	Hopkins Engineering Co. San Fernando, Calif.	14841	Ward Leonard Electric Co. Hagerstown, Md.
05397	Union Carbide Corp. Linde Division, Kemet Dept. Cleveland, Ohio		

(Cont'd)



TABLE 6-1. MANUFACTURER'S CODE (Cont'd)

Number	Name	Number	Name
14936	General Instrument Corp. Semi-Conductor Division Hicksville, Long Island, N. Y.	74306	Piezo Crystal Co. Carlisle, Pa.
16665	The Singer Co. Metrics Division Bridgeport, Conn.	76493	J. W. Miller Co. Los Angeles, Calif.
37942	P. R. Mallory and Co., Inc. Indianapolis, Ind.	78488	Stackpole Carbon Co. St. Marys, Pa.
44655	Ohmite Mfg. Co. Skokie, Ill.	78526	Stanwyck Winding Co., Inc. Newburgh, N. Y.
56289	Sprague Electric Co. North Adams, Mass.	79727	Continental-Wirt Electronics Corp. Philadelphia, Pa.
71279	Cambridge Thermionic Corp. Cambridge, Mass.	80294	Bourns, Inc. Riverside, Calif.
71450	CTC Corp. Elkhart, Inc.	81349	Military Specifications
71590	Centralab Division of Globe-Union, Inc. Milwaukee, Wis.	82142	Jeffers Electronics Division of Speer Carbon Co. DuBois, Pa.
72136	Electro-Motive Mfg. Co., Inc. Willimantic, Conn.	82389	Switchcraft, Inc. Chicago, Ill.
72928	Gudeman Co. Chicago, Ill.	83186	Victory Engineering Corp. Springfield, N. J.
72982	Erie Technological Products, Inc. Erie, Pa.	91929	Minneapolis-Honeywell Regulator Co. Micro-Switch Division Freeport, Ill.
73138	Beckman Instruments, Inc. Helipot Division Fullerton, Calif.	93332	Sylvania Electric Products, Inc. Semiconductor Products Division Woburn, Mass.
73899	J. F. D. Electronics Corp. Brooklyn, N. Y.	98291	Sealectro Corp. Mamaroneck, N. Y.
		99942	Hoffman Electronics Corp. Evanston, Ill.

TABLE 6-2. PARTS LIST

Ref Symbol	Description	Manufacturer's Part Number	Mfr's Code	Maint Qty
C1 C4	THRU CAPACITOR, FIXED, CERAMIC DISC, 0.01 UF, 250V SINGER PART NO. 556060-146	DA140-172B	71590	1
C6	CAPACITOR, MICA, DIPPED, 200 PF, PORM 5 PCT, 500V SINGER PART NO. 150-2002-201EJO	DM15E201J0500WV4CR	72136	1
C7	CAPACITOR, FIXED, 100 UF, 35V SINGER PART NO. 556146-523	MTP107M035PIC	37942	1
C8 C9	AND CAPACITOR, FIXED, CERAMIC, 0.1 UF, PORM 20 PCT, 200V SINGER PART NO. 556120-098	338C104N	72928	1
C10	CAPACITOR, MICA DIPPED, 100 PF, PORM 5 PCT, 500V SINGER PART NO. 150-2002-101EJO	DM15E101J0500WV4CR	72136	1
C11	CAPACITOR, FIXED, DIPPED MICA, 820 PF, PORM 5 PCT, 500V SINGER PART NO. 150-2002-821EJO	DM15E821J0500WV4CR	72136	1
C12	CAPACITOR, FIXED, DIPPED MICA, 7 PF, PORM 5PCT 500V SINGER PART NO. 150-2002-7R0EJO	DM15E7R0J0500WV4CR	72136	1
C13 C14	AND SAME AS C10			
J1 J5	THRU CONNECTOR, JACK, 28 PIN SINGER PART NO. 556146-916	K600-5PCGD	79727	1
J6	CONNECTOR, RECEPTACLE SINGER PART NO. 168-4006-001	UG 1094/U	81349	1
J7	CONNECTOR, JACK SINGER PART NO. 556146-546	460	02660	1
J8	CONNECTOR, FEMALE SINGER PART NO. 556146-560	57HA3F	82389	1
L1	CHCKE, RF, 4.7UH SINGER PART NO. 556012-199	09-4436-8	82142	1
L2 L3	AND INDUCTOR, 470UH SINGER PART NO. 556012-202	TYPE D1NK	78526	1
L4	CHCKE, R.F., 0.47 UH SINGER PART NO. 556012-216	09-4426-2	82142	2
P1	CONNECTOR, MALE SINGER PART NO. 556166-045	26-159-16	02260	1
P2	CONNECTOR, PLUG SINGER PART NO. 556010-266	51-011-C000	98291	1
P3 P4	AND CONNECTOR, PLUG SINGER PART NO. 168-4031-001	51-007-C000	98291	1
R1	RESISTOR, FIXED, COMP., 150 OHMS, PORM 5 PCT, 1/4W SINGER PART NO. 151-1002-151J	CB1515	01121	1
R2	RESISTOR, VARIABLE, 250 OHMS, PORM 20 PCT, 1/2W	151-0001-052	16665	1
R3	RESISTOR, VARIABLE, 1K OHM, PORM 20 PCT, 1/2W	151-C001-051	16665	1
R4	RESISTOR, FIXED, WIRE-WOUND, 390 OHMS, PORM 5 PCT, 3W SINGER PART NO. 151-2001-391J	FR-3-390	14841	1
R5	RESISTOR, FIXED, WIRE-WOUND, 360 OHMS, PORM 5 PCT, 3W SINGER PART NO. 151-2001-361J	FR-3-360	14841	1
R6	RESISTOR, FIXED, WIRE-WOUND, 330 OHMS, PORM 5 PCT, 3W SINGER PART NO. 151-2001-331J	FR-3-330	14841	1
R7	RESISTOR, VARIABLE, 100 OHMS, PORM 20 PCT SINGER PART NO. 556146-511	GA2G200P101MA	01121	1

Section VI  
Parts List

TABLE 6-2. PARTS LIST

Ref Symbol	Description	Manufacturer's Part Number	Mfr's Code	Maint Qty
R8	RESISTOR,VAIRBALE, 10K OHMS, PORM 3 PCT, 1/2W SINGER PART NO. 556146-510	3520S-1-103	80294	1
R9	RESISTOR,VARIABLE, 10K PORM 10 PCT SINGER PART NO. 556146-512	GA2G028P103BA	01121	1
R10	RESISTOR,VARIABLE, 250 OHMS, PORM 20 PCT SINGER PART NO. 556146-509	TYPE300	71450	1
R11	RESISTOR,VARIABLE, 500K PORM 20 PCT, 1/2W SINGER PART NO. 556146-526	GA2G200P504MA	01121	1
R12	RESISTOR,VARIABLE, 50K OHMS,PORM 3 PCT,2W SINGER PART NO. 151-0004-C07	3500S-1-503	80294	1
R13	RESISTOR,VARIABLE, 1K OHMS,PORM 20 PCT SINGER PART NO. 556146-508	TYPE GA2	01121	1
R14	RESISTOR,VARIABLE, 1MEGOHM,PORM 20 PCT, 1/2W SINGER PART NO. 556146-525	GA2G200P105TA	01121	1
R15	RESISTOR,FIXED,PREC., 226 OHMS,PORM 0.5 PCT, 1/8W SINGER PART NO. 151-1006-B2260D	C1/8E2260HMPORM.5PCT	12126	1
R16	RESISTOR,FIXED,PREC., 137 OHMS,PORM .5 PCT, 1/8W SINGER PART NO. 151-1006-B137D	C1/8E1370HMPORM.5PCT	12126	1
R17	RESISTOR,FIXED,PREC., 76.8 OHMS,PORM .5 PCT, 1/8W SINGER PART NO. 151-1006-B76R8D	C1/8E76.80HMPORM.5PC	12126	1
R18	RESISTOR,FIXED,PREC., 42.2 OHMS,PORM .5 PCT, 1/8W SINGER PART NO. 151-1006-B42R2D	C1/8E42.20HMPORM.5PC	12126	1
R19	RESISTOR,FIXED,PREC., 56.2 OHMS,PORM .5 PCT, 1/8W SINGER PART NO. 151-1006-B56R2D	C1/8E56.20HMPORM.5PC	12126	1
R20	RESISTOR,VARIABLE, 250 OHMS, PORM 20 PCT SINGER PART NO. 556146-513	GA2G200P251MA	01121	1
R21	RESISTOR,FIXED,COMP., 100 OHMS,PORM 5 PCT, 1/4W SINGER PART NO. 151-1002-101J	CB1015	01121	1
S1	SWITCH,INPUT,IMPEDANCE SINGER PART NO. 556146-519	G-123	79727	1
S2	SWITCH,ROCTARY, 2 POLE 4 POSITION	133-0060-001	16665	1
S3	SWITCH,ROCTARY, 10 POLE 4 POSITION	133-0063-001	16665	1
S4	SWITCH,ROCTARY, 3 POLE 2 POSITION	133-0059-001	16665	1
S5	SWITCH,ROCTARY, 1 POLE 5 POSITION	133-0062-001	16665	1
S6	SWITCH,ROCTARY, 3 POLE 2 POSITION	133-0061-001	16665	1
A1	D.C. CONTROL ASSEMBLY	103-1208-001	16665	1
A1CR1	SEMICONDUCTOR DEVICE,DIODE SINGER PART NO. 556146-548	232	12060	1
A1CR2 A1CR5	THRU SEMICONDUCTOR DEVICE,DIODE SINGER PART NO. 556118-202	IN935	81349	1
A1CR6	SEMICONDUCTOR DEVICE,DIODE SINGER PART NO. 556118-195	2320	12060	1
A1CR7	SAME AS A1CR2			

TABLE 6-2. PARTS LIST

Ref Symbol	Description	Manufacturer's Part Number	Mfr's Code	Maint Qty
A1CR8	SEMICONDUCTOR DEVICE, DIODE SINGER PART NO. 556118-046	IN251	93332	1
A1CR9 THRU A1CR11	SEMICONDUCTOR DEVICE, DIODE SINGER PART NO. 556166-041	IN270	44655	1
A1CR12 THRU A1CR16	SAME AS A1CR8			
A1C1	CAPACITOR, ELECTROLYTIC, 2.2UF, 35V SINGER PART NO. 556146-506	K2R2J35KS	05397	1
A1C2 AND A1C3	CAPACITOR, FIXED, PAPER 0.1UF, PORM 20 PCT, 200 VDCW SINGER PART NO. 556120-120	P12D	02777	3
A1C4	SAME AS A1C1			
A1C5	SAME AS C1			
A1C6	SAME AS C10			
A1C7	CAPACITOR, ELECTROLYTIC, 68 UF, 15V SINGER PART NO. 556146-504	K47J35S	05397	3
A1C8	SAME AS C10			
A1C9	SAME AS C7			
A1Q1 AND A1Q2	TRANSISTOR SINGER PART NO. 556146-254	2N3565	07263	1
A1Q3	TRANSISTOR	556146-652	16665	1
A1Q4	TRANSISTOR SINGER PART NO. 556166-087	2N2270	07933	1
A1Q5	TRANSISTOR SINGER PART NO. 556146-401	2N3638A	81349	1
A1Q6	SAME AS A1Q1			
A1Q7	SAME AS A1Q5			
A1Q8	SAME AS A1Q1			
A1Q9	SAME AS A1Q5			
A1Q10 AND A1Q11	SAME AS A1Q1			
A1Q12	SAME AS A1Q5			
A1Q13	SAME AS A1Q1			
A1R1	RESISTOR, FIXED, COMP., 10000 OHMS, PORM 5 PCT, 1/4W SINGER PART NO. 151-1002-103J	CB1035	01121	4
A1R2	RESISTOR, FIXED, COMP., 3300 OHMS, PORM 5 PCT, 1/4W SINGER PART NO. 151-1002-332J	CB3325	01121	2
A1R3	RESISTOR, VARIABLE, 25K OHMS SINGER PART NO. 556146-539	FC253M	01121	1
A1R4	RESISTOR, FIXED, WIRE-WOUND, 68 OHMS, PORM 5 PCT, 1W SINGER PART NO. 556146-551	239E6805	56289	1
A1R5	RESISTOR, FIXED, COMP., 160 OHMS, PORM 5 PCT, 1/2W SINGER PART NO. 151-1003-161J	EB1615	01121	1

Section VI  
Parts List

TABLE 6-2. PARTS LIST

Ref Symbol	Description	Manufacturer's Part Number	Mfr's Code	Maint Qty
A1R6	RESISTOR, FIXED, COMP., 15000 OHMS, PORM 5 PCT, 1/4W SINGER PART NO. 151-1002-153J	CB1535	01121	1
A1R7	RESISTOR, VARIABLE, 10K OHMS, PORM 20 PCT SINGER PART NO. 556146-507	FC103M	01121	1
A1R8	RESISTOR, FIXED, COMP., 27000 OHMS, PORM 5 PCT, 1/4W SINGER PART NO. 151-1002-273J	CB2735	01121	2
A1R9	RESISTOR, FIXED, COMP., 24000 OHMS, PORM 5 PCT, 1/4W SINGER PART NO. 151-1002-243J	CB2435	01121	1
A1R10	RESISTOR, FIXED, COMP., 390000 OHMS, PORM 5 PCT 1/4W SINGER PART NO. 151-1002-394J	CB3945	01121	1
A1R11	RESISTOR, FIXED, COMP., 3000 OHMS, PORM 5 PCT, 1/4W SINGER PART NO. 151-1002-302J	CB3015	01121	2
A1R12	RESISTOR, FIXED, COMP., 100 OHMS, PORM 5 PCT, 1/2W SINGER PART NO. 151-1003-101J	EB1015	01121	1
A1R13	RESISTOR, FIXED, COMP., 6800 OHMS, PORM 5 PCT, 1/4W SINGER PART NO. 151-1002-682J	CB6825	01121	2
A1R14	RESISTOR, FIXED, COMP., 4700 OHMS, PORM 5 PCT, 1/4W SINGER PART NO. 151-1002-472J	CB4725	01121	2
A1R15	RESISTOR, FIXED, COMP., 12000 OHMS, PORM 5 PCT, 1/4W SINGER PART NO. 151-1002-123J	CB1235	01121	2
A1R16	RESISTOR, FIXED, COMP., 18000 OHMS, PORM 5 PCT, 1/4W SINGER PART NO. 151-1002-183J	CB1835	01121	1
A1R17	SAME AS A1R7			
A1R18	RESISTOR, VARIABLE, 50K OHMS, PORM 30 PCT, 1/4W SINGER PART NO. 556056-129	X201R503B	71450	1
A1R19	RESISTOR, FIXED, COMP., 51000 OHMS, PORM 5 PCT, 1/4W SINGER PART NO. 151-1002-513J	CB5135	01121	1
A1R20 AND A1R21	RESISTOR, FIXED, COMP., 56000 OHMS, PORM 5 PCT, 1/4W SINGER PART NO. 151-1002-563J	CB5635	01121	2
A1R22	SAME AS A1R8			
A1R23	RESISTOR, FIXED, COMP., 5600 OHMS, PORM 5 PCT, 1/4W SINGER PART NO. 151-1002-562J	CB5625	01121	2
A1R24	SAME AS A1R8			
A1R25 AND A1R26	RESISTOR, FIXED, COMP., 4300 OHMS, PORM 5 PCT, 1/4W SINGER PART NO. 151-1002-432J	CB4325	01121	3
A1R27	SAME AS A1R1			
A1R28	RESISTOR, FIXED, COMP., 1500 OHMS, PORM 5 PCT, 1/4W SINGER PART NO. 151-1002-152J	CB1525	01121	3
A1R29	SAME AS A1R8			
A1R30	SAME AS A1R20			
A1R31	RESISTOR, VARIABLE 5K OHMS SINGER PART NO. 556146-541	XHT201-5K	71450	1
A1R32	SAME AS A1R13			

TABLE 6-2. PARTS LIST

Ref Symbol	Description	Manufacturer's Part Number	Mfr's Code	Maint Qty
A1R33	RESISTOR, FIXED, COMP., 5100 OHMS, PORM 5 PCT, 1/4W SINGER PART NO. 151-1002-512J	CB5125	01121	2
A1R34	SAME AS A1R23			
A1R35	SAME AS A1R25			
A1R36	RESISTOR, FIXED, COMP., 2000 OHMS, PORM 5 PCT, 1/4W SINGER PART NO. 151-1002-202J	CB2025	01121	3
A1R37	SAME AS A1R13			
A1R38	RESISTOR, FIXED, COMP., 9.1K OHMS, PORM 5 PCT, 1/4W SINGER PART NO. 151-1002-912J	CB9125	01121	1
A1R39 A1R42	THRU SAME AS A1R31			
A1R43	RESISTOR, VARIABLE, 1K OHMS, SINGER PART NO. 556056-124	X201R102B	71450	1
A1R44	RESISTOR, FIXED, COMP., 910 OHMS, PORM 5 PCT, 1/4W SINGER PART NO. 151-1002-911J	CB9115	01121	1
A1R45	RESISTOR, FIXED, COMP., 51 OHMS, PORM 5 PCT, 1/4W SINGER PART NO. 151-1002-510J	CB5105	01121	3
A1R46	RESISTOR, VARIABLE, 100 OHMS SINGER PART NO. 556146-549	350PC101A	71450	1
A1R47	RESISTOR, FIXED, COMP., 22 OHMS, PORM 5 PCT, 1/4W SINGER PART NO. 151-1002-220J	CB2205	01121	
A1R48	SAME AS A1R46			
A1R49	RESISTOR, FIXED, COMP., 82 OHMS, PORM 5 PCT, 1/4W SINGER PART NO. 151-1002-820J	CB8205	01121	1
A1R50	SAME AS A1R46			
A1R51	SAME AS R21			
A1R52	SAME AS A1R46			
A1R53	RESISTOR, FIXED, COMP., 12 OHMS, PORM 5 PCT, 1/4W SINGER PART NO. 151-1002-120J	CB1205	01121	1
A1R54	SAME AS A1R46			
A1R55	SAME AS A1R18			
A1R56	SAME AS R21			
A1R57	RESISTOR, FIXED, COMP., 200 OHMS, PORM 5 PCT, 1/4W SINGER PART NO. 151-1002-201J	CB2015	01121	3
A1R58	RESISTOR, VARIABLE, 2.5K PORM 20 PCT, 1/8W SINGER PART NO. 556146-55C	XT201	71450	1
A2	2.7MHZ 1-F AMP/DETECTOR ASSEMBLY	103-1210-001	16665	1
A2CR1	SEMICONDUCTOR, DEVICE, DIODE SINGER PART NO. 556118-168	IN906	81349	1
A2CR2 A2CR3	AND SAME AS A1CR8			

Section VI  
Parts List

TABLE 6-2. PARTS LIST

Ref Symbol	Description	Manufacturer's Part Number	Mfr's Code	Maint Qty
A2C1	CAPACITOR,CERAMIC,DISC, 0.05MF, 80 PCT, 200V SINGER PART NO. 556074-057	33C137	56289	1
A2C2 AND A2C3	SAME AS C1			
A2C4	SAME AS A1C2			
A2C5	CAPACITOR,VARIABLE, 9 TO 50 PF, SINGER PART NO. 556146-552	3192-000N750	72928	2
A2C6	SAME AS C10			
A2C7 AND A2C8	SAME AS C1			
A2C9	SAME AS A1C2			
A2C10	SAME AS A2C5			
A2C11	SAME AS C10			
A2C12 THRU A2C19	SAME AS C1			
A2C20	SAME AS A1C2			
A2C21	CAPACITOR,MICA,DIPPED, 33 PF,PORM 5 PCT,500V SINGER PART NO. 150-2002-331EJC	DM15E330J0500WV4CR	72136	1
A2C22	CAPACITOR,ELECTROLYTIC, 47UF, 35V SINGER PART NO. 556146-505	K47J35S	05397	1
A2C23	SAME AS A1C2			
A2C24	SAME AS C1			
A2C25	SAME AS A2C1			
A2L1 AND A2L2	SAME AS L2			
A2L3	COIL,RF,100UH SINGER PART NO. 556012-191	1326-7K	82142	1
A2L4	COIL,RF,2.2MH SINGER PART NO. 556012-173	70F223A1	76493	1
A2Q1 THRU A2Q4	TRANSISTOR SINGER PART NO. 556017-059	2N2188	81349	1
A2Q5	SAME AS A1Q5			
A2Q6	SAME AS A2Q1			
A2Q7	TRANSISTOR SINGER PART NO. 556017-057	2N1091	81349	1
A2Q8	SAME AS A1Q4			
A2R1 AND A2R2	RESISTOR,FIXED,COMP., 20000 OHMS, PORM 5 PCT 1/4W SINGER PART NO. 151-1002-203J	CB2035	01121	2
A2R3	SAME AS R21			
A2R4	RESISTOR,FIXED,COMP., 1000 OHMS,PORM 5 PCT, 1/4W SINGER PART NO. 151-1002-102J	CB1025	01121	3
A2R5	RESISTOR,FIXED,COMP., 33000 OHMS,PORM 5 PCT, 1/4W SINGER PART NO. 151-1002-333J	CB3335	01121	3

TABLE 6-2. PARTS LIST

Ref Symbol	Description	Manufacturer's Part Number	Mfr's Code	Maint Qty
A2R6	SAME AS A1R13			
A2R7	SAME AS A1R45			
A2R8	SAME AS A2R5			
A2R9	RESISTOR, FIXED, COMP., 2200 OHMS, PORM 5 PCT, 1/4W SINGER PART NO. 151-1002-222J	CB2225	01121	3
A2R10	SAME AS A2R5			
A2R11	SAME AS A1R13			
A2R12	SAME AS A1R57			
A2R13	RESISTOR, VARIABLE, 500 OHMS, PORM 30 PCT, 1/4W SINGER PART NO. 556056-13C	X201R501B	71450	1
A2R14	SAME AS A1R11			
A2R15	SAME AS A2R5			
A2R16 AND A2R17	SAME AS A1R33			
A2R18	SAME AS R21			
A2R19	RESISTOR, FIXED, COMP., 510 OHMS, PORM 5 PCT, 1/4W SINGER PART NO. 151-1002-511J	CB5115	01121	2
A2R20	RESISTOR, FIXED, COMP., 300 OHMS, PORM 5 PCT, 1/4W SINGER PART NO. 151-1002-301J	CB3015	01121	1
A2R21	SAME AS A1R1			
A2R22	SAME AS A2R9			
A2R23	RESISTOR, FIXED, COMP., 430 OHMS, PORM 5 PCT, 1/4W SINGER PART NO. 151-1002-431J	CB4315	01121	1
A2R24	SAME AS A1R1			
A2R25	SAME AS A1R43			
A2R26 AND A2R27	SAME AS A1R1			
A2R28	RESISTOR, FIXED, COMP., 220000 OHMS, PORM 5 PCT 1/4W SINGER PART NO. 151-1002-224J	CB224B	01121	1
A2R29	SAME AS R21			
A2T1 AND A2T2	TRANSFORMER, I-F	132-0111-001	16665	1
A2T3	TRANSFORMER, DETECTOR	132-0113-001	16665	1
A3	32.238MHZ I-F AMP/2ND MIXER/29.538MHZ OSC ASSEMBLY	103-1212-001	16665	1
A3C1	CAPACITOR, VARIABLE, 2 TO 8PF, SINGER PART NO. 556146-553	538-006NPO	72982	1
A3C2	SAME AS C11			
A3C3	SAME AS C1			



TABLE 6-2. PARTS LIST

Ref Symbol	Description	Manufacturer's Part Number	Mfr's Code	Maint Qty
A3C4	CAPACITOR, FIXED, CERAMIC DISC, 0.01 UF, PLUS 80, MINUS 20 PCT, 100V SINGER PART NO. 556060-084	805-D00X5V103Z	72982	1
A3C5	CAPACITOR, MICA, DIPPED, 68 PF, PORM 5 PCT, 300V SINGER PART NO. 150-2002-680EJC	DM15E680J0300WV4CR	72136	1
A3C6	SAME AS C11			
A3C7	SAME AS C1			
A3C8	SAME AS A3C2			
A3C9	SAME AS A3C5			
A3C10 AND A3C11	SAME AS C1			
A3C12	SAME AS A2C1			
A3C13	CAPACITOR, MICA, DIPPED, 1000 PF, PORM 5 PCT, 100V SINGER PART NO. 150-2002-102EJC	DM15E102J0100WV4CR	72136	1
A3C14	CAPACITOR, MICA, DIPPED, 24 PF, PORM 5 PCT, 100V SINGER PART NO. 150-2002-270CJC	DM15C240J0100WV4CR	72136	1
A3C15	SAME AS A2C5			
A3C16	SAME AS C6			
A3C17	CAPACITOR, MICA, DIPPED, 56 PF, PORM 5 PCT, 300V SINGER PART NO. 150-2002-560EJC	DM15E560J0300WV4CR	72136	1
A3C18	CAPACITOR, MICA, DIPPED, 120 PF, PORM 5 PCT 500V SINGER PART NO. 150-2002-121EJC	DM15E121J0500WV4CR	72136	1
A3C19	SAME AS A2C5			
A3C20 THRU A3C22	SAME AS C1			
A3J1	CONNECTOR, JACK SINGER PART NO. 556146-441	3320-2-03	71279	1
A3L1	SAME AS L1			
A3L2	CHCKE, RF, 5.6UH SINGER PART NO. 556012-200	09-4446-1	82142	1
A3L3	SAME AS L4			
A3L4	SAME AS A3L2			
A3P1	CONNECTOR, PLUG SINGER PART NO. 556146-440	2971-2	71279	1
A3Q1 THRU A3Q3	TRANSISTOR SINGER PART NO. 556146-923	2N4917	81349	1
A3Q4	SAME AS A1Q1			
A3R1	RESISTOR, FIXED, COMP., 2700 OHMS, PORM 5 PCT, 1/4W SINGER PART NO. 151-1002-272J	CB2725	01121	1
A3R2	RESISTOR, FIXED, COMP., 470 OHMS, PORM 5 PCT, 1/4W SINGER PART NO. 151-1002-471J	CB4715	01121	1
A3R3	SAME AS A1R25			
A3R4	RESISTOR, FIXED, COMP., 110 OHMS, PORM 5 PCT, 1/4W SINGER PART NO. 151-1002-111J	CB1115	01121	1

TABLE 6-2. PARTS LIST

Ref Symbol	Description	Manufacturer's Part Number	Mfr's Code	Maint Qty
A3R5	SAME AS A1R25			
A3R6	SAME AS A3R2			
A3R7	SAME AS A3R1			
A3R8	SAME AS A3R4			
A3R9	SAME AS A1R8			
A3R10	SAME AS A1R15			
A3R11	SAME AS A1R11			
A3R12	SAME AS A3R1			
A3R13	SAME AS A2R5			
A3R14	SAME AS A1R51			
A3R15	SAME AS A1R45			
A3R16	SAME AS A2R9			
A3R17	SAME AS A2R23			
A3R18	SAME AS A2R5			
A3R19	RESISTOR, FIXED, COMP., 6200 OHMS, PORM 5 PCT, 1/4W SINGER PART NO. 151-1002-622J	CB6225	01121	2
A3R20	RESISTOR, FIXED, COMP., 390 OHMS, PORM 5 PCT, 1/4W SINGER PART NO. 151-1002-391J	CB3915	01121	1
A3T1 AND A3T2	TRANSFORMER, I-F, ADJUSTABLE CORE	132-0114-001	16665	1
A3T3	TRANSFORMER, I-F	132-0112-001	16665	1
A3T4	AUTOTRANSFORMER	132-0115-001	16665	1
A3Y1	CRYSTAL, 29.538MHZ	556146-554	16665	1
A4	2.7MHZ CRYSTAL FILTER ASSEMBLY	103-1211-001	16665	1
A4CR1 THRU A4CR4	SAME AS A2CR1			
A4CR5	SAME AS A1CR8			
A4C1	SAME AS C1			
A4C2	SAME AS A3C1			
A4C3	SAME AS A2C5			
A4C4 AND A4C5	SAME AS A2C1			
A4C6	SAME AS C1			
A4C7	SAME AS A2C1			
A4C8 THRU A4C11	SAME AS C1			
A4C12	SAME AS A1C7			

Section VI  
Parts List

TABLE 6-2. PARTS LIST

Ref Symbol	Description	Manufacturer's Part Number	Mfr's Code	Maint Qty
A4C13	SAME AS A3C1			
A4C14	SAME AS A2C5			
A4C15	SAME AS A2C1			
A4C16 THRU A4C18	SAME AS C1			
A4C19	SAME AS A2C5			
A4C20	CAPACITOR, MICA, DIPPED, 330 PF, PORM 5 PCT, 500J SINGER PART NO. 150-2002-331EJO	DM15E331J0500WV4CR	72136	1
A4C21	CAPACITOR, FIXED, COMP., 3.9PF, PORM 5 PCT, 500VDC SINGER PART NO. 150-4001-3R9J	TYPE GA	78488	1
A4C22	SAME AS A4C20			
A4C23	SAME AS A2C5			
A4C24	SAME AS A4C21			
A4C25	SAME AS A4C20			
A4C26	SAME AS A2C5			
A4C27 AND A4C28	SAME AS C1			
A4L1 THRU A4L4	SAME AS L2			
A4L5 THRU A4L7	CHOKER, RF 10UH SINGER PART NO. 556146-555	09-4446-4K	82142	1
A4Q1 THRU A4Q6	SAME AS A1Q5			
A4Q7	SAME AS A1Q1			
A4Q8	SAME AS A1Q5			
A4Q9	TRANSISTOR SINGER PART NO. 556146-251	2N3563	14936	1
A4Q10	SAME AS A1Q5			
A4R1	RESISTOR, FIXED, COMP., 2200 OHMS, PORM 5 PCT, 1/4W SINGER PART NO. 151-1002-223J	CB2235	01121	1
A4R2	SAME AS A1R25			
A4R3	SAME AS A1R57			
A4R4	RESISTOR, FIXED, COMP., 240 OHMS, PORM 5 PCT, 1/4W SINGER PART NO. 151-1002-241J	CB2415	01121	1
A4R5	SAME AS A3R2			
A4R6	SAME AS A1R57			
A4R7	SAME AS A1R2			
A4R8	SAME AS A1R15			
A4R9	RESISTOR, FIXED, COMP., 7500 OHMS, PORM 5 PCT, 1/4W SINGER PART NO. 151-1002-752J	CB7525	01121	1

TABLE 6-2. PARTS LIST

Ref Symbol	Description	Manufacturer's Part Number	Mfr's Code	Maint Qty
A4R10	SAME AS A1R25			
A4R11	RESISTOR, FIXED, COMP., 680 OHMS, PORM 5 PCT, 1/4W SINGER PART NO. 151-1002-681J	CB6815	01121	1
A4R12	RESISTOR, FIXED, COMP., 120 OHMS, PORM 5 PCT, 1/4W SINGER PART NO. 151-1002-121J	CB1215	01121	1
A4R13	SAME AS A2R4			
A4R14	SAME AS A4R9			
A4R15	SAME AS A1R25			
A4R16	SAME AS A4R11			
A4R17	SAME AS A4R12			
A4R18	SAME AS A2R4			
A4R19	SAME AS A4R1			
A4R20	SAME AS A1R25			
A4R21	SAME AS A1R57			
A4R22	SAME AS A4R4			
A4R23	SAME AS A3R2			
A4R24	SAME AS A1R51			
A4R25	SAME AS A1R57			
A4R26	SAME AS A1R1			
A4R27	SAME AS A1R2			
A4R28	SAME AS A1R15			
A4R29	SAME AS A2R4			
A4R30	SAME AS A2R28			
A4R31	RESISTOR, FIXED, COMP., 11K OHMS, PORM 5 PCT, 1/4W SINGER PART NO. 151-1002-113J	CB1135	01121	1
A4R32	SAME AS A1R57			
A4R33	SAME AS A4R31			
A4R34	SAME AS A2R1			
A4R35	RESISTOR, FIXED, COMP., 1200 OHMS, PORM 5 PCT, 1/4W SINGER PART NO. 151-1002-122J	CB1225	01121	1
A4R36	SAME AS A2R19			
A4R37	SAME AS A2R5			
A4R38	RESISTOR, FIXED, COMP., 39000 OHMS, PORM 5 PCT, 1/4W SINGER PART NO. 151-1002-393J	CB3935	01121	1
A4R39	SAME AS A1R57			
A4R40	SAME AS A1R28			

TABLE 6-2. PARTS LIST

Ref Symbol	Description	Manufacturer's Part Number	Mfr's Code	Maint Qty
A4T1 AND A4T2	TRANSFORMER, I-F	132-0110-001	16665	1
A4Y1 AND A4Y2	CRYSTAL, 2.7 MC SINGER PART NO. 556025-131	0033091-4	74306	1
A5	MULTIVIBRATOR/MARKER ASSEMBLY	103-1216-001	16665	1
A5A1	MICRO CKT DIVIDER SINGER PART NO. 556146-522	CVL958	02335	1
A5CR1 THRU A5CR8	SEMICONDUCTOR DEVICE, DIODE SINGER PART NO. 556146-146	IN995	14936	1
A5CR9	SAME AS A2CR1			
A5CR10 AND A5CR11	SAME AS A1CR9			
A5CR12	SAME AS A1CR1			
A5CR13 AND A5CR14	SAME AS A5CR1			
A5CR15	SEMICONDUCTOR, DEVICE, DIODE SINGER PART NO. 556146-520	V-33B	01281	1
A5C1 AND A5C2	SAME AS A1C2			
A5C3 AND A5C4	SAME AS C1			
A5C5	CAPACITOR, MICA, DIPPED, 47 PF, PORM 5 PCT, 500V SINGER PART NO. 150-2002-47CEJC	DM15E470J0500WV4CR	72136	2
A5C6	CAPACITOR, MICA, DIPPED, 10 PF, PORM 5 PCT, 500V SINGER PART NO. 150-2002-10CCJC	DM15C100J0500WV4CR	72136	2
A5C7	SAME AS A2C21			
A5C8	CAPACITOR, FIXED, DIPPED MICA, 15 PF, PORM 5 PCT 500V SINGER PART NO. 556125-007	DM15C150J0500WV	72136	1
A5C9	SAME AS C1			
A5C10	SAME AS A5C8			
A5C11	SAME AS C1			
A5C12	SAME AS A5C8			
A5C13	SAME AS A5C5			
A5C14	SAME AS A5C6			
A5C15	SAME AS A2C21			
A5C16	SAME AS A5C8			
A5C17	SAME AS A1C1			
A5C18	SAME AS A1C2			
A5C19	CAPACITOR, MICA, DIPPED, 5 PF, PORM 0.5 PF, 500V SINGER PART NO. 150-2002-5RCCDC	DM15C5RGDC0500WV4CR	72136	1

TABLE 6-2. PARTS LIST

Ref Symbol	Description	Manufacturer's Part Number	Mfr's Code	Maint Qty
A5C20 A5C21	AND SAME AS C1			
A5C22	SAME AS A1C2			
A5C23 A5C24	AND SAME AS A5C6			
A5C25 A5C26	AND SAME AS A5C5			
A5C27 A5C28	AND SAME AS A5C8			
A5C29	SAME AS A5C5			
A5C30	SAME AS A5C6			
A5C31	SAME AS A5C5			
A5C32	SAME AS A5C6			
A5C33	CAPACITOR, MICA, DIPPED, 27 PF, PORM 5 PCT, 100V SINGER PART NO. 150-2002-270CJO	DM15C270J0100WV4CR	72136	1
A5C34	CAPACITOR, MICA, DIPPED, 150 PF, PORM 5 PCT, 500V SINGER PART NO. 150-2002-151EJO	DM15E151J0500WV4CR	72136	1
A5C35 A5C36	AND CAPACITOR, MICA, DIPPED, 300 PF, PORM 1 PCT, 500V SINGER PART NO. 150-2002-301EFO	DM15E301F0500WV4CR	72136	1
A5C37	SAME AS A5C34			
A5C38	SAME AS A1C6			
A5C39 A5C41	THRU SAME AS C1			
A5C42 A5C43	AND SAME AS A5C6			
A5C44 A5C45	AND SAME AS A5C6			
A5C46	SAME AS A1C2			
A5C47 A5C49	THRU SAME AS A3C13			
A5C50	SAME AS A5C19			
A5C51 A5C54	THRU SAME AS C1			
A5C55	SAME AS A5C19			
A5C56 A5C57	AND SAME AS A5C33			
A5C58 A5C59	AND CAPACITOR, MICA, DIPPED, 510 PF, PORM 5 PCT, 500V SINGER PART NO. 150-2002-511EJO	DM15E511J0500WV4CR	72136	1
A5C60	SAME AS C10			
A5C61 A5C62	AND SAME AS A5C58			

TABLE 6-2. PARTS LIST

Ref Symbol	Description	Manufacturer's Part Number	Mfr's Code	Maint Qty
A5L1	SAME AS L1			
A5L2	SAME AS L2			
A5L3 A5L6	THRU SAME AS L4			
A5L7	CHCKE,C.33UH SINGER PART NO. 556012-198	4416-7	82142	1
A5L8	INDUCTOR,2.2MH SINGER PART NO. 556012-217	70F223A1	76493	1
A5Q1 A5Q4	THRU TRANSISTOR SINGER PART NO. 556146-256	2N3646	81349	1
A5Q5 A5Q6	AND SAME AS A4Q9			
A5Q7 A5Q10	THRU SAME AS A5Q1			
A5Q11 A5Q12	AND SAME AS A2Q1			
A5Q13	SAME AS A4Q9			
A5Q14 A5Q15	AND SAME AS A5Q1			
A5Q16	SAME AS A4Q9			
A5Q17	TRANSISTOR SINGER PART NO. 556118-201	2N2996	81349	1
A5Q18	SAME AS A4Q9			
A5Q19 A5Q20	AND TRANSISTOR SINGER PART NO. 556166-086	2N706A	01295	1
A5R1	SAME AS A1R36			
A5R2	RESISTOR, FIXED, COMP., 8200 OHMS, PORM 5 PCT, 1/4W SINGER PART NO. 151-1002-822J	C88225	01121	3
A5R3	SAME AS A1R36			
A5R4	SAME AS A5R2			
A5R5	RESISTOR, FIXED, COMP., 240 OHMS, PORM 5 PCT, 1/4W SINGER PART NO. 151-1002-241J	C82415	01121	1
A5R6 A5R7	AND SAME AS A1R1			
A5R8	SAME AS A1R43			
A5R9	SAME AS A1R14			
A5R10	SAME AS A3R19			
A5R11 A5R12	AND SAME AS A1R1			
A5R13 A5R14	AND SAME AS A5R2			
A5R15	SAME AS A1R14			
A5R16 A5R17	AND SAME AS A1R36			

TABLE 6-2. PARTS LIST

Ref Symbol	Description	Manufacturer's Part Number	Mfr's Code	Maint Qty
A5R18	SAME AS A1R2			
A5R19	SAME AS A1R23			
A5R20	SAME AS A3R19			
A5R21	SAME AS A1R28			
A5R22	SAME AS A5R2			
A5R23 A5R24	AND SAME AS A1R36			
A5R25	SAME AS A5R2			
A5R26	SAME AS A1R1			
A5R27	SAME AS A4R11			
A5R28 A5R29	AND SAME AS A1R1			
A5R30	SAME AS A5R2			
A5R31 A5R32	AND SAME AS A1R36			
A5R33	SAME AS A5R2			
A5R34	SAME AS A1R1			
A5R35	SAME AS A1R51			
A5R36	SAME AS A2R4			
A5R37	SAME AS A1R14			
A5R38	SAME AS A2R4			
A5R39	SAME AS A1R14			
A5R40	SAME AS A1R36			
A5R41	SAME AS A2R20			
A5R42	SAME AS A1R11			
A5R43	RESISTOR, FIXED, CCMP., 300 OHMS, PORM 5 PCT, 1W SINGER PART NO. 151-1004-301J	GB3015	01121	1
A5R44	SAME AS A2R4			
A5R45	SAME AS A1R28			
A5R46	SAME AS A1R36			
A5R47	SAME AS A1R23			
A5R48	SAME AS A1R36			
A5R49	SAME AS A5R2			
A5R50 A5R51	AND SAME AS A1R1			
A5R52	SAME AS A5R2			



TABLE 6-2. PARTS LIST

Ref Symbol	Description	Manufacturer's Part Number	Mfr's Code	Maint Qty
A5R53	SAME AS A1R36			
A5R54	SAME AS A2R2C			
A5R55	RESISTOR, FIXED, COMP., 75 OHMS, PORM 5 PCT, 1/4w SINGER PART NO. 151-1002-750J	CB7505	01121	1
A5R56	SAME AS A1R36			
A5R57	SAME AS A2R4			
A5R58	SAME AS A1R1			
A5R59	SAME AS A1R33			
A5R60	SAME AS A1R45			
A5R61	SAME AS A1R28			
A5R62	SAME AS A1R1			
A5R63	SAME AS A2R9			
A5R64	SAME AS A2R2C			
A5R65	RESISTOR, FIXED, COMP., 200 OHMS, PORM 5 PCT, 1/2w SINGER PART NO. 151-1003-201J	EB2015	01121	1
A5R66	SAME AS A1R51			
A5R67 AND A5R68	SAME AS A1R2C			
A5R69	SAME AS A2R19			
A5R70 AND A5R71	RESISTOR, FIXED, COMP., 10000 OHMS, PORM 5 PCT 1/4w SINGER PART NO. 151-1002-104J	CB1045	01121	2
A5R72 AND A5R73	SAME AS A1R45			
A5R74	SAME AS A2R19			
A5R75	SAME AS A1R36			
A5R76	SAME AS A1R43			
A5R77	SAME AS A1R25			
A5R78	SAME AS A2R4			
A5Y1	CRYSTAL, 5MHZ	556146-556	16665	1
A6	LOG-LIN ASSEMBLY	103-1215-001	16665	1
A6CR1 AND A6CR2	SEMICONDUCTOR, DEVICE, DIODE SINGER PART NO. 556166-034	HU-10	99942	1
A6R1	RESISTOR, VARIABLE, 1K OHMS SINGER PART NO. 556146-516	62PR-1K	73138	1
A6R2	RESISTOR, VARIABLE, 20K OHMS SINGER PART NO. 556146-515	62PR20K	73138	1
A6R3	RESISTOR, VARIABLE, 50K OHMS SINGER PART NO. 556146-516	62PR50K	73138	1

TABLE 6-2. PARTS LIST

Ref Symbol	Description	Manufacturer's Part Number	Mfr's Code	Maint Qty
A6R4	RESISTOR, FIXED, COMP., 510K OHMS, PCRM 5 PCT, 1/4W SINGER PART NO. 151-1002-514J	CB5145	01121	1
A6R5	RESISTOR, VARIABLE, 500K OHMS SINGER PART NO. 556146-K57	62PR500K	73138	1
A6VR1	VARISTOR SINGER PART NO. 151-5001-001	623L13	83186	1
A7	NARROW BAND LC ASSEMBLY	103-1204-001	16665	1
A7CR1	SAME AS A5CR15			
A7C1 A7C2	AND SAME AS C1			
A7C3	SAME AS A3C5			
A7C4 A7C5	AND SAME AS C1			
A7C6	SAME AS A5C6			
A7C7	SAME AS A3C14			
A7C8	SAME AS A5C33			
A7C9 A7C10	AND SAME AS C1			
A7C11	SAME AS A3C13			
A7C12	CAPACITOR, MICA, DIPPED, 7500 PF, PCRM 5 PCT, 100V SINGER PART NO. 150-2002-331EJG	DM30E752J0100WV4CR	72136	1
A7C13	SAME AS C1			
A7C14	SAME AS A3C5			
A7C15	SAME AS A2C21			
A7J1	CONNECTOR, JACK SINGER PART NO. 168-3003-001	51-053-0000	98291	1
A7L1	CHECKER, RF, 22UF SINGER PART NO. 556012-201	09-1316-4	82142	1
A7L2	INDUCTOR, VARIABLE	132-0191-001	16665	1
A7L3	CHECKER, RF, 0.1UH SINGER PART NO. 556012-218	09-4426-2	82142	1
A7L4	SAME AS A2L3			
A7L5	SAME AS L1			
A7L6	SAME AS A3L2			
A7C1 A7C4	THRU SAME AS A4C9			
A7R1	SAME AS A1R6			
A7R2	SAME AS A5R2			
A7R3 A7R4	AND RESISTOR, FIXED, COMP., 330 OHMS, PCRM 5 PCT, 1/4W SINGER PART NO. 151-1002-331J	CB3315	01121	1
A7R5 A7R6	AND SAME AS A2R9			

TABLE 6-2. PARTS LIST

Ref Symbol	Description	Manufacturer's Part Number	Mfr's Code	Maint Qty
A7R7	SAME AS A2R19			
A7R8 AND A7R9	SAME AS A5R7C			
A7R1C	SAME AS A1R51			
A7R11	SAME AS A2R9			
A7R12	SAME AS A2R2C			
A7R13	SAME AS A1R1			
A7R14	SAME AS A3R2C			
A7R15	RESISTOR, FIXED, COMP., 750 OHMS, PORM 5 PCT, 1/4w SINGER PART NO. 151-1002-751J	CB7515	01121	1
A7R16	SAME AS A1R1			
A7R17	SAME AS A2R4			
A7R18	SAME AS A1R45			
A8	FIRST MIXER ASSEMBLY	103-1207-001	16665	1
A8C1	SAME AS A1C7			
A8C2 AND A8C3	SAME AS C1			
A8C4	SAME AS A1C7			
A8C5	SAME AS C1			
A8C6	SAME AS A1C7			
A8C7	SAME AS C1			
A8C8	SAME AS A1C7			
A8C9 AND A8C10	SAME AS C1			
A8C11	SAME AS A1C7			
A8C12	CAPACITOR, MICA, DIPPED, 300 PF, PORM 5 PCT, 500V SINGER PART NO. 150-2002-301EJC	DM15E301J0500WV4CR	72136	1
A8C13	SAME AS C1			
A8C14	SAME AS A3C5			
A8C15	CAPACITOR, VARIABLE, 0.8 TO 4.5 PF SINGER PART NO. 556146-559	VC-10G	73899	1
A8J1	SAME AS A3J1			
A8P1	SAME AS A3P1			
A8Q1 THRU A8Q4	SAME AS A4Q9			
A8R1	SAME AS A5R55			
A8R2	RESISTOR, FIXED, COMP., 33 OHMS, PORM 5 PCT, 1/4w SINGER PART NO. 151-1002-330J	CB3305	01121	2

TABLE 6-2. PARTS LIST

Ref Symbol	Description	Manufacturer's Part Number	Mfr's Code	Maint Qty
A8R3	SAME AS A1R1			
A8R4	SAME AS A3R19			
A8R5	RESISTOR,VARIABLE, 10K OHMS SINGER PART NO. 556146-527	62PR10K	73138	1
A8R6	SAME AS A8R2			
A8R7	RESISTOR, FIXED, COMP., 220 OHMS, PORM 5 PCT, 1/4w SINGER PART NO. 151-1002-221J	CB2215	01121	1
A8R8 AND A8R9	SAME AS A8R2			
A8R10	SAME AS A1R57			
A8R11	RESISTOR,VARIABLE, 100 OHM SINGER PART NO. 556146-558	62PR100	73138	1
A8R12	SAME AS A1R13			
A8R13	SAME AS A2R1			
A8R14 AND A8R15	SAME AS A1R25			
A8R16	SAME AS A2R1			
A8R17	SAME AS A1R23			
A8R18	SAME AS A8R2			
A8R19	SAME AS A2R4			
A8R20	SAME AS A8R2			
A8R21 AND A8R22	SAME AS A1R2			
A8R23	SAME AS A1R28			
A8T1	SAME AS A3T1			
A9	INPUT ATTENUATOR ASSEMBLY	103-1094-001	16665	1
A9J1 AND A9J2	CONNECTOR,JACK SINGER PART NO. 556010-267	51-047-0000	98291	1
A9R1	RESISTOR, FIXED, PREC., 107 OHMS, PORM 1 PCT, 1/8w SINGER PART NO. 556146-531	CI/8E107CHMPORM1PCT	12126	1
A9R2 AND A9R3	RESISTOR, FIXED, PREC., 143 OHMS, PORM 1 PCT 1/8w SINGER PART NO. 556146-530	CI/8E143OHMPORM1PCT	12126	1
A9R4	RESISTOR, FIXED, PREC., 374 OHMS, PORM 1 PCT, 1/8w SINGER PART NO. 556146-532	CI/8E374OHMPORM1PCT	12126	1
A9R5 AND A9R6	RESISTOR, FIXED, PREC., 90.9 OHMS, PORM 1 PCT, 1/8w SINGER PART NO. 556146-529	CI/8E909OHMPORM1PCT	12126	1
A9R7	RESISTOR, FIXED, PREC., 3740 OHMS, PORM 1 PCT, 1/8w SINGER PART NO. 556146-533	CI/8E3740OHMPORM1PCT	12126	1
A9R8 AND A9R9	RESISTOR, FIXED PREC., 75 OHMS, PORM 1 PCT, 1/8w SINGER PART NO. 556146-528	CI/8E75CHMPORM1PCT	12126	1
A9S1	SWITCH, MICRO	149-0164-001	16665	1

## ADDENDUM

for

### VIDEO MODULE MODEL VR-4

#### I. PURPOSE.

To provide a more effective touchup alignment procedure for use when a Model VR-4 Video Module is installed in a new or different main frame, and satisfactory operation cannot be obtained.

#### NOTE 1

It should not be assumed that this touchup alignment is automatically necessary when a module is newly installed. The touchup alignment should be performed only if, satisfactory operation cannot be obtained using normal operating controls. Under no circumstances should the module interior alignment controls be touched until the main frame being used has been checked out and aligned as required. These checkout and alignment procedures are given in the manual supplied with the main frame under Minimum Performance Standards, Section IV.

#### NOTE 2

If a new video module is apparently malfunctioning, contact the factory or the nearest Singer Company Field Representative before making adjustments inside the module.

#### II. ADDENDUM.

The following addendum is divided into two parts. Together, they replace paragraphs 4-13 and 4-14 of the Model VR-4 Video Module instruction manual. The Video Module has been factory aligned and should not require any realignment under normal conditions. However, since the module is aligned with a particular main frame, the following procedures may have to be performed when installing the module in a new or different main frame at the user's facility. Part A, the standard touchup alignment, also serves to verify that a particular (video) module and main frame combination will meet specifications. Part B, a more detailed touchup alignment procedure, is used if the results of part A do not meet specifications. Part B should never be required when a module and main frame are ordered and received together. To perform the touchup alignment, proceed as follows:

Part A:

- a. Plug the module into the main frame.
- b. Connect the main frame power cord to a 115 volt, 50-60 Hz, single-phase ac power source.
- c. Apply power to the main frame as follows: On Model MF-2 rotate the ILLUM OFF control CW. On Model MF-5 rotate the SCALE ILLUMINATION-PWR OFF control CW.

- d. Set the controls on the module as follows:

INPUT ATTEN DB switch	70 dB
SWEEP RANGE switch	0 - 25 MHz PRESET
I-F ATTEN DB switch	10 dB
AMPLITUDE SCALE switch	LOG
SMOOTHING FILTER control	Fully CCW
SWEEP MODE switch	AUTO SCAN
MARKERS switch	5 MHz

- e. Adjust the marker AMPLITUDE control on the module for a clear display of the 5 MHz markers on the main frame CRT.
- f. Adjust the 0 Hz BALANCE controls to minimize the zero pip amplitude.
- g. Alternately, adjust the horizontal position and horizontal size controls on the main frame, until the 0, 5, 10, 15, 20 and 25 MHz marker pips coincide with the corresponding frequency divisions of the CRT graticule within  $\pm 1/2$  division; for example, the zero marker on the extreme left vertical line, 5 MHz on the third vertical line, 10 MHz on the fifth vertical line, etc.

- h. Set the controls on the module as follows:

MARKERS switch	OFF
AMPLITUDE control	Fully CW (MAX)
CENTER FREQUENCY 0 - 25 MHz dial	00.1 MHz
SWEEP WIDTH dial	0.1 MHz
SWEEP RANGE switch	50 kHz - 5 MHz

INPUT ATTEN DB switch	0 dB
I-F BANDWIDTH control	Fully CW (MAX)
INPUT switch	50 ohms

- i. Obtain a signal generator, such as the Hewlett-Packard Model 651 B or equivalent with a 50 ohm output impedance.
- j. Set the signal generator to provide an output of 100 kHz at 1 millivolt.
- k. Connect a shielded coaxial cable between the 50-ohm output connector of the signal generator (some have a switch to change the impedance) and the INPUT connector of the module.
- l. Adjust the signal generator output until the pip on the CRT display is full scale. Note that 0 dB on LOG amplitude scale is not the uppermost horizontal graticule calibration line.
- m. While observing the CRT display, set the INPUT ATTEN DB switch on the module to 10 dB, then 20 dB, then 30 dB, and then 40 dB, successively, noting each time that the signal pip declines to the -10 dB, -20 dB, -30 dB, and -40 dB divisions of the CRT graticule, respectively. The tolerance should be within  $\pm 0.20$  division (0 to -30 dB) or  $\pm 0.40$  division (-30 dB to -40 dB). If the decrease in signal pip amplitude is not within the stated tolerances, alternately adjust the VERT and VERTICAL SIZE screwdriver controls on the Model MF-2 main frame (for MF-5, VERT POS and V SIZE), until the observed attenuation meets the specification. If the unit does not meet the specifications, refer to the detailed touchup alignment in Part B of this addendum.

#### Part B:

DETAILED TOUCHUP ALIGNMENT. To be performed only after Part A is completed.

- a. Obtain a dc vacuum-tube voltmeter (VTVM) with full-scale ranges of 1.5 and 15 volts dc, such as an R. C. A. Model WV-98C or equivalent. A digital voltmeter or avolt-ohm-milliammeter (VOM) may be used if available.
- b. Using the service cable supplied, connect the module to a Model MF-2 or MF-5 main frame.
- c. Connect the power cord on the main frame to a 105 - 125 volt, 60 Hz single-phase ac power source.
- d. Apply power to the main frame and to the VTVM and wait 15 minutes for warm up.

- e. Balance the zero pip to its minimum amplitude in accordance with procedure 2.8i through 2.8h in the VR-4 instruction manual.
- f. Set the SWEEP RANGE switch control on the module to 50 kHz - 5 MHz.
- g. Set the function switch on the VTVM to +dc volts, the range switch to 15.
- h. Connect the positive lead of the VTVM to pin 12 of the service cable connector attached to the rear of the module. (Connector pins have identifying numbers molded in for identification.)

#### NOTE

Sleeving on pins of the service cable connector can be pushed back to expose the solder terminals for electrical contact.

- i. Connect the negative lead of the VTVM to pin 9 of the connector, or to the metal chassis of the module.
- j. Adjust the sweep rate VAR control (inner knob concentric with the SWEEP MODE switch) on the module for a +2 volt reading on the VTVM.
- k. Observe the spot trace location on the CRT display. If it is not located at the +0.5 division (right-hand margin) of the CRT graticule, adjust the horizontal position control on the main frame (HORIZ, MF-2; HORIZ POS, MF-5) until it is exactly located on this division.
- l. Adjust the sweep rate VAR control on the module for a +8 volt indication on the VTVM.
- m. Observe the spot trace location on the CRT display. If it is not located at the -0.5 division (left-hand margin) of the CRT graticule, adjust the horizontal size control on the main frame until it is exactly located on this division.

#### NOTE

On Model MF-2 the horizontal size control is a screwdriver adjustment located under the lower chassis plug on the right-hand side of the cabinet. On Model MF-5 the horizontal size control is a screwdriver adjustment marked H SIZE.

- n. Alternately repeat steps j through m until the +2 and +8 volt readings on the VTVM correspond to a spot trace movement from the +0.5 to -0.5 graticule dimensions, respectively.



o. Set the controls on the module as follows:

INPUT ATTEN DB switch	70 dB
SWEEP RANGE switch	0 - 25 MHz PRESET
I-F ATTEN DB switch	10 dB
AMPLITUDE SCALE switch	LOG
SMOOTHING FILTER control	Fully CCW
SWEEP MODE switch	AUTO SCAN
MARKERS switch	5 MHz

p. Adjust the AMPLITUDE control on the module for a visible display of the 5 MHz markers on the main frame CRT.

q. The 0, 5, 10, 15, 20, and 25 MHz marker pips should coincide with the corresponding frequency divisions of the CRT graticule within  $\pm 1/2$  division. If not, slight readjustment of the horizontal position and size controls will be necessary.

r. Set the controls on the module as follows:

INPUT ATTEN DB switch	0 dB
CENTER FREQUENCY 0 - 25 MHz dial	05.0 MHz
I-F ATTEN DB switch	20 dB
VARIABLE control	Fully CCW
MARKERS switch	5 MHz
AMPLITUDE control	Fully CW
SWEEP WIDTH dial	0.1 MHz
SWEEP RANGE switch	50 kHz - 5 MHz
I-F BANDWIDTH control	Fully CW
AMPLITUDE SCALE switch	LIN
SMOOTHING FILTER control	Fully CCW
SWEEP MODE switch	AUTO SCAN
SWEEP MODE VAR control	Fully CW

- s. Set the VTVM range switch to +1.5 volts,
- t. Adjust the vertical position control on the main frame until the baseline of the trace on the CRT display is coincident with the bottom division of the graticule.
- u. Adjust the FREQ CAL thumbwheel control on the module so that the 5 MHz marker pip is centered on the CF division of the CRT graticule.
- v. Set the SWEEP MODE switch on the module to MANUAL.
- w. Adjust the SWEEP MODE VAR control on the module until the spot trace is coincident with the bottom division of the CRT graticule.
- x. Connect the positive lead of the VTVM to pin 1 of the service cable connector.
- y. Connect the negative lead of the VTVM to chassis ground.
- z. Adjust the SWEEP MODE VAR control on the module until the spot trace is at the highest attainable point on CRT display.
- aa. Adjust the MARKER AMPLITUDE control on the module until the VTVM reads  $1.4 \pm 0.050$  volts dc.
- ab. Adjust the vertical size control, if necessary, until the spot trace is coincident with the full scale amplitude division on the CRT graticule.

#### NOTE

On Model MF-2 the vertical size control is a screwdriver adjustment located under the upper chassis plug on the right-hand side of the cabinet. On Model MF-5, the vertical size control is a screwdriver adjustment on the front panel labelled V SIZE.

- ac. Adjust the SWEEP MODE VAR control on the module until the VTVM reads 0 volts, with the CRT display at its lowest position on the graticule.
- ad. Adjust the vertical position control (VERT on Model MF-2 and VERT POS on Model MF-5) on the main frame until the spot trace is again set at the bottom division of the CRT graticule.

#### NOTE

The vertical size and position controls on the main frame interact somewhat, requiring alternate adjustments several times in some cases.

- ae. Repeat steps ab through ad until the full scale shift of the spot trace on the CRT display corresponds to a  $1.4 \pm 0.05$  volt shift on the VTVM.
- af. Disconnect the VTVM from pin 1 of the service cable connector.

ag. Set the controls on the module as follows:

MARKERS switch	OFF
AMPLITUDE control	Fully CW (MAX)
CENTER FREQUENCY 0 - 25 MHz dial	00.1 MHz
SWEEP WIDTH dial	0.1 MHz
SWEEP RANGE switch	50 kHz - 5 MHz
INPUT ATTEN DB switch	0 dB
I-F BANDWIDTH control	Fully CW (MAX)
INPUT switch	50 ohms.

- ah. Obtain a signal generator such as the Hewlett-Packard Model 651B or equivalent with a 50 ohm output impedance.
- ai. Set the signal generator to provide an output of 100 kHz at 1 millivolt.
- aj. Connect a shielded coaxial cable between the 50-ohm output connector of the signal generator (some have a switch to change the impedance) and the INPUT connector of the module.
- ak. Adjust the signal generator output until the pip on the CRT display is full scale.
- al. While observing the CRT display, set the INPUT ATTEN DB switch on the module to 10 dB, then 20 dB, then 30 dB, and then 40 dB, successively, noting each time that the signal pip declines to the -10 dB, -20 dB, -30 dB, and -40 dB divisions of the CRT graticule, respectively. The tolerances should be within  $\pm 0.20$  division (0 to -30 dB) or  $\pm 0.40$  division (-30 dB to -40 dB). If the decrease in signal pip amplitude is not within the stated tolerances, slight readjustment of the VERT and VERTICAL SIZE screwdriver controls on the Model MF-2 main frame (for MF-5, VERT POS and V SIZE), is required until the attenuation is within the stated specification.
- am. Remove the service cable and install the module in the main frame.