

# **OWNERS MANUAL**

## **VC-100**

**THE VOICE CONTROLLER**

## Description

1. The VC-100 has many features which let you enjoy clear communication.
2. The speech inversion method is employed for voice scrambler (SCRAM). Transmission carrier is controlled by the stable crystal oscillator and receiving signal is controlled by the variable oscillator which can be compensated by the SHIFT control at the front panel, for ideal operation.
3. The echo function (ECHO) can be adjusted its amount and delay time by monitoring with built-in monitor speaker for desirable echo level.
4. The speech compressor function (COMP) evens the voice level whether you speak close to or away from the microphone.
5. The melody function (MELO) let you identify your signal by adding musical signal when starting transmission. The signal can be selected from two choices.
6. The end of transmission pilot signal function (PEE) is used to let your partner know the end of

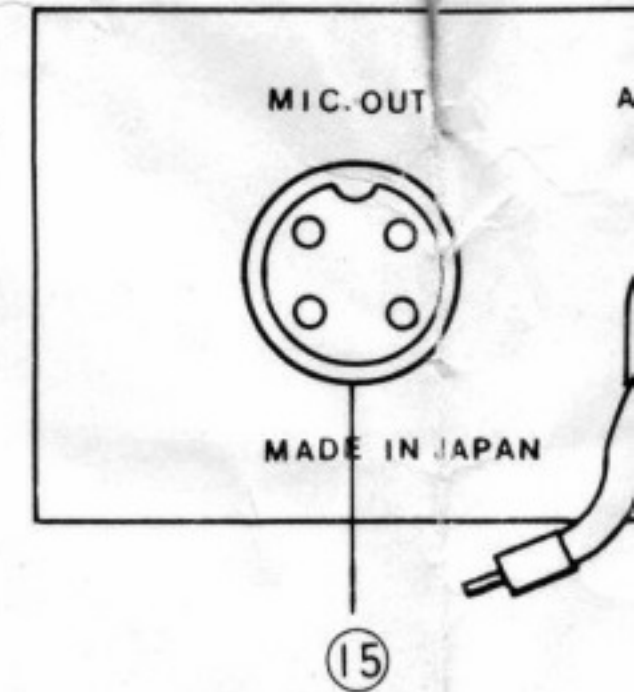
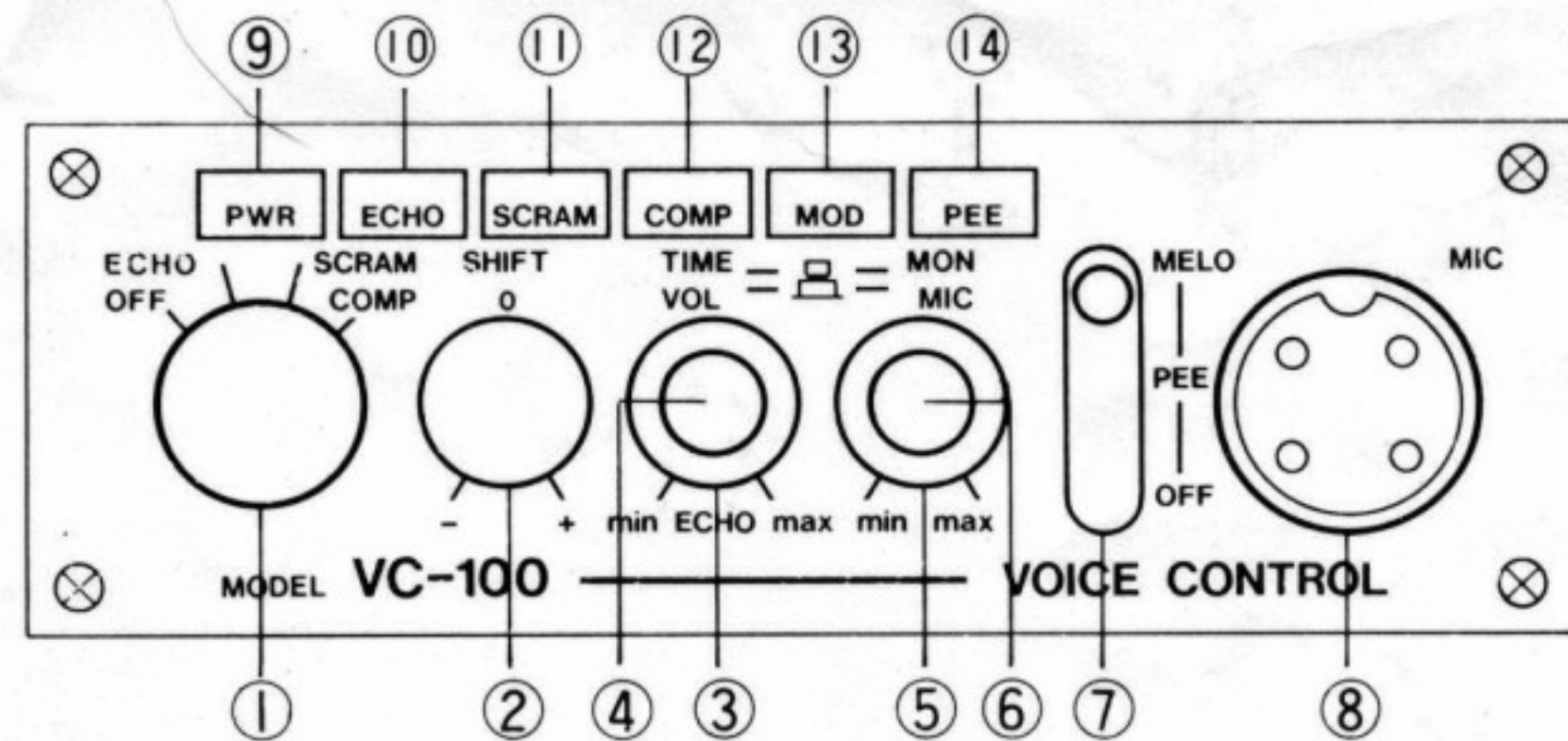

transmission. Tone of the signal can be selected from the choices.

### Name and function of each section

#### 1. OFF-ECHO-SCRAM-COMP selector switch

The switch is used to select echo (ECHO), scrambler (SCRAM), speech compressor (COMP) or through (OFF) function.

#### 2. SHIFT

To compensate receiving local oscillator frequency to decode clear voice signal when the scrambler is in operation.

#### 3. ECHO VOL

To adjust amount of reverberation when the ECHO function is in operation. By turning this on the

right, reverberation volume is increased.

#### 4. ECHO TIME

To adjust reverberation time when the ECHO function is in operation. By turning this on the right, reverberation time is shortened.

#### 5. MIC

To adjust microphone input level. Adjustment should be done by considering microphone gain, voice level and surrounding noise.

#### 6. MONI

To adjust output level of the built-in speaker. By turning this on the right, sound becomes louder.

#### 7. MELO-PEE-OFF selector switch

This switch is used to select the



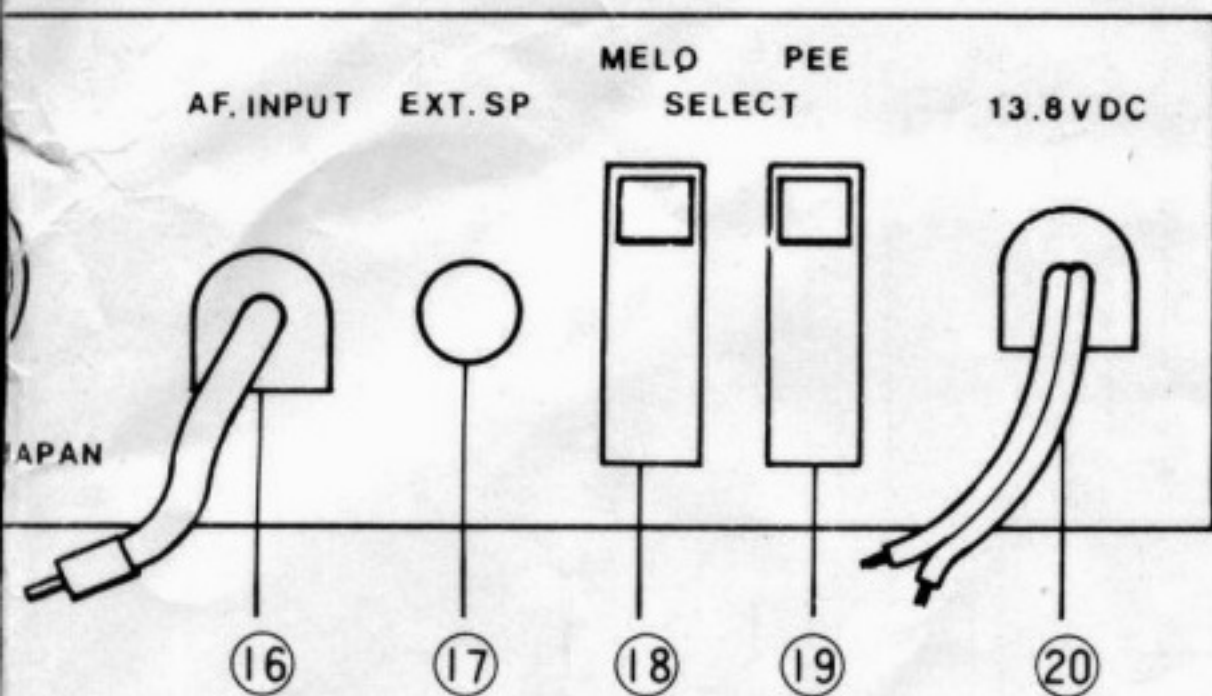

melody (MELO) or end of transmission pilot signal (PEE) function.

#### 8. MIC

Microphone input. Since pin to pin connections of microphone connectors and receptacles are different in each transceiver manufacture, rewiring of those have to be made according to the schematic diagram.

#### 9. POWER indicator

Lit when the unit is in operation.

#### 10. ECHO indicator

Lit when the ECHO function is in operation.

#### 11. SCRAM indicator

Lit when the voice scrambler is in operation.

#### 12. COMP indicator

Lit when the speech compressor is in operation.

#### 13. MOD indicator

Flashed depending on the level of the voice signal from the microphone.

#### 14. PEE indicator

Lit when the end of transmission pilot signal function is in operation.

#### 15. MIC OUT

AF output for microphone input of the transceiver. Since shape and pin to pin connections of microphone connectors and receptacles are different in each transceiver manufactures.

#### 16. AF INPUT

When the scrambler is used, connect this to the external speaker output of the transceiver. Be sure not to apply AF input exceeding the maximum rating from the transceiver.

#### 17. EXT SP

Audio output to connect the external speaker.

#### 18. MELO SELECT

To select musical signal from two choices.

#### 19. PEE SELECT

To select the end of transmission pilot signal from two choices.

#### 20. POWER cable

Connect this to the 13.8V DC (11 to 15V) power line. Red is positive and black is negative polarities.

### Connections

1. Connect the microphone to the MIC receptacle at the front panel of the unit.

Note: Since shape and pin to pin connections of the microphone connectors and receptacles may be different, be sure to see them before connection.

2. Connect the MIC OUT at the rear of the unit and microphone receptacle of the transceiver.
3. Connect the AF INPUT cable to the external speaker output at the transceiver. The unit is being operated normally without this connection except when the built-in speaker of the unit is used or the scrambler is operated. External speaker can be connected to the EXT SP output at the rear of the unit.



4. Connect power cable to a car battery or DC power supply. Line voltage is 13.8V DC (11 to 15V) and red is connected to the positive polarity and black is the negative.

## Operation

1. Using the ECHO function.
  - a. Turn off the power switch of the transceiver.
  - b. Set the SWITCH 1 to the ECHO position.
  - c. While pressing the PTT button of the microphone and speaking to it, set the amount of reverberation and delay time by turning the ECHO VOL and ECHO TIME controls. At the same time, output level of the built-in speaker can be adjusted by the MON control.
  - d. Turn on the power switch of the transceiver.
  - e. While pressing the PTT button of the microphone and talking to it, set the MIC control to have adequate output level to the transceiver. Normally set it at the center position when conventional microphone is being used.

- f. Then the unit is ready to be operated.
2. Using the SCRAM function.
    - a. Set the SWITCH 1 to the SCRAM position.
    - b. Set the SHIFT control to the center position.
    - c. In order to avoid applying excess AF input to the unit, set the AF control of the transceiver to approximately ten o'clock position.
    - d. Then the unit is ready to be operated. If receiving signal can not be decoded clearly, compensate the SHIFT control right or left to have it clear. If the signal can not be decoded clearly by compensating the SHIFT control, adjust the AF control of the transceiver, for it is most likely due to excess or insufficient AF input level to the unit.

Note: Although high pitch oscillating sound may be heard when unmodulated signal is received, it is not a trouble of the unit. In addition, if received signal is not strong enough, the signal can not be decoded clearly.

3. Using the COMP function.
  - a. Set the SWITCH 1 to the COMP position.
  - b. Then the speech compressor is in operation and output AF level becomes even whether you speak close to or away from the microphone. Note that surrounding noise may also be amplified by this function.
4. Using the MELO function.
  - a. Set the SWITCH 1 to the MELO position.
  - b. Then the musical signal is sent by pressing the PTT button. This function can be operated when the SWITCH 1 is set to either the ECHO, SCRAM or COMP position and can not be operated when it is set to the OFF position. Since it becomes reverberated musical signal when it is used with the ECHO function and scrambled one when it is used with the SCRAM function, it can be used for adjusting those functions.
  - c. Desired musical signal can be selected from two choices by the MELO SELECT switch at the rear of the unit.
5. Using the end of transmission



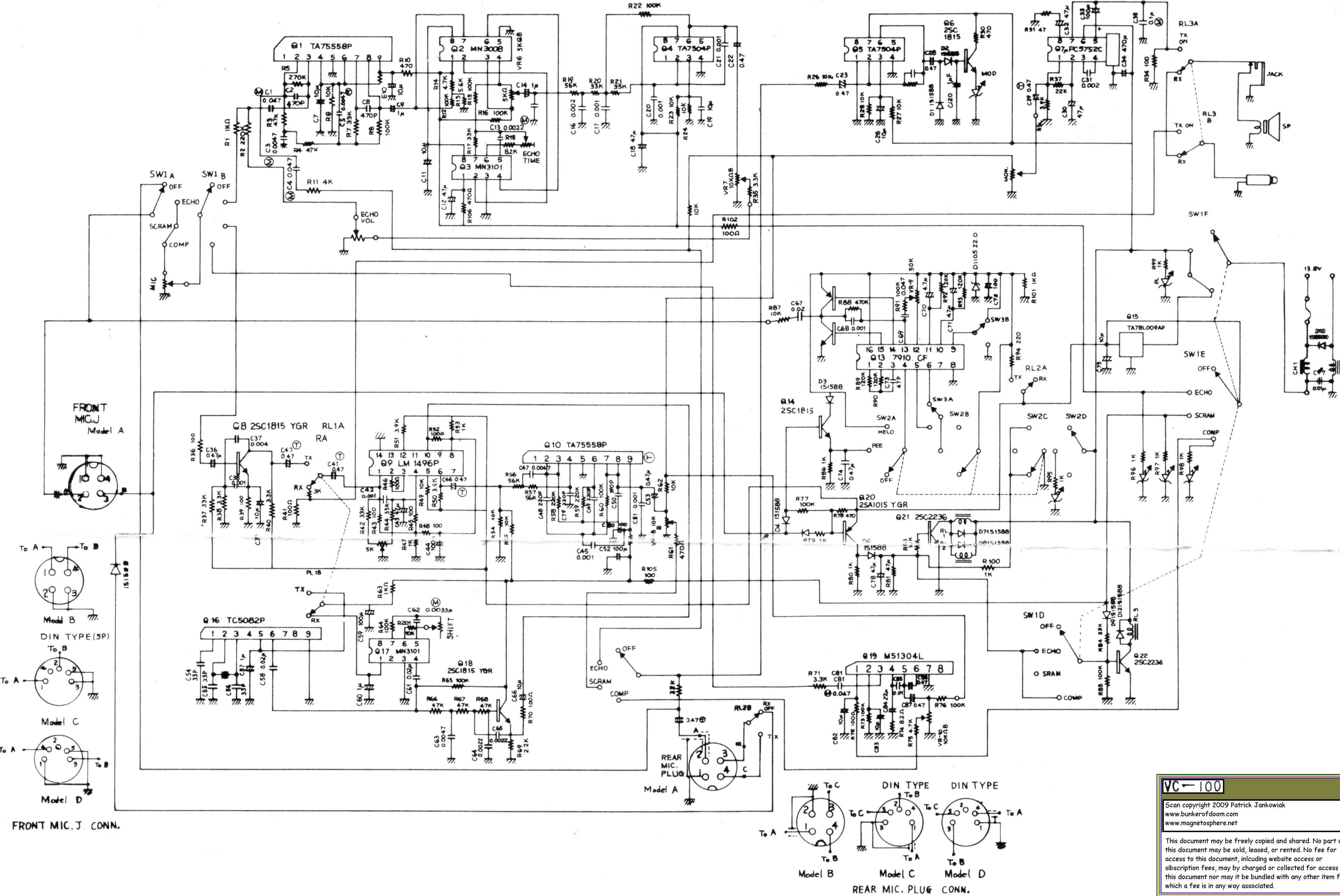

FRONT MIC. J. CONN.

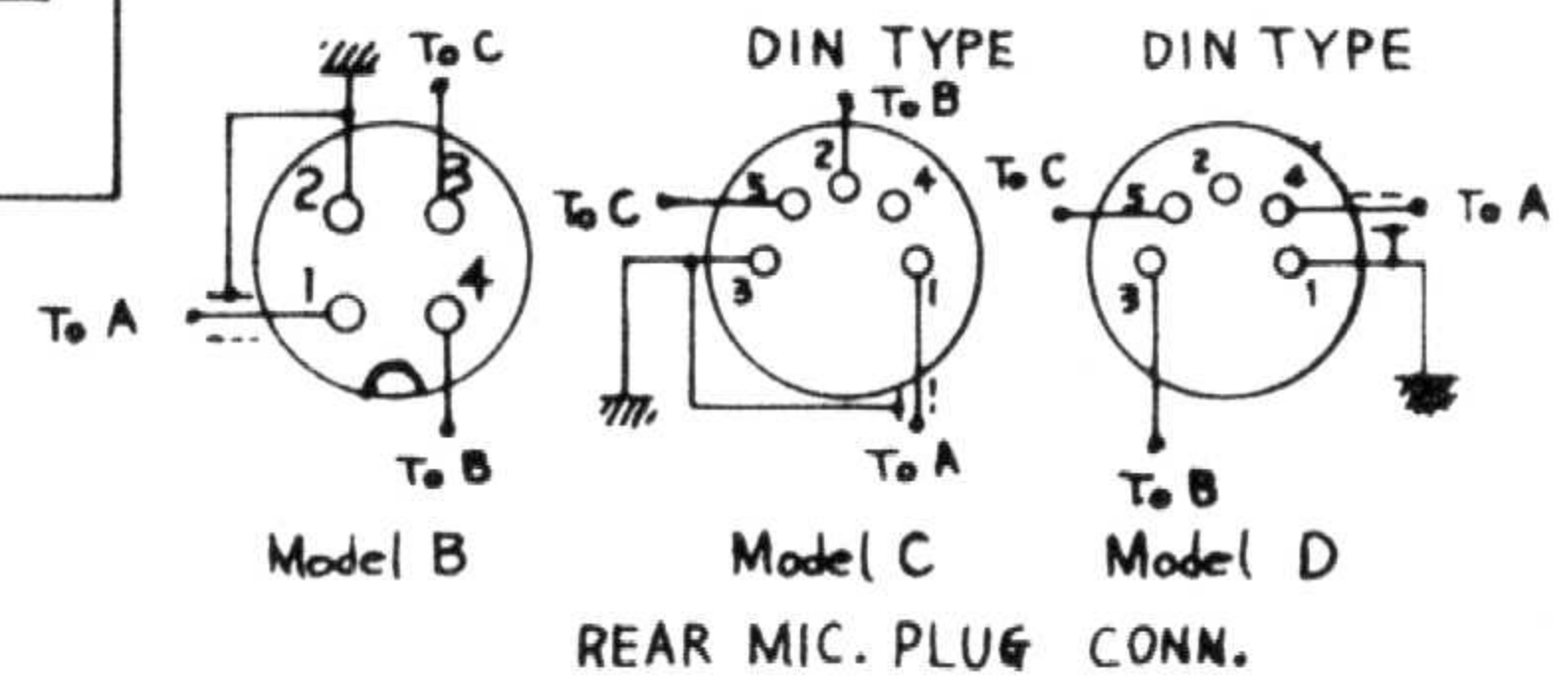
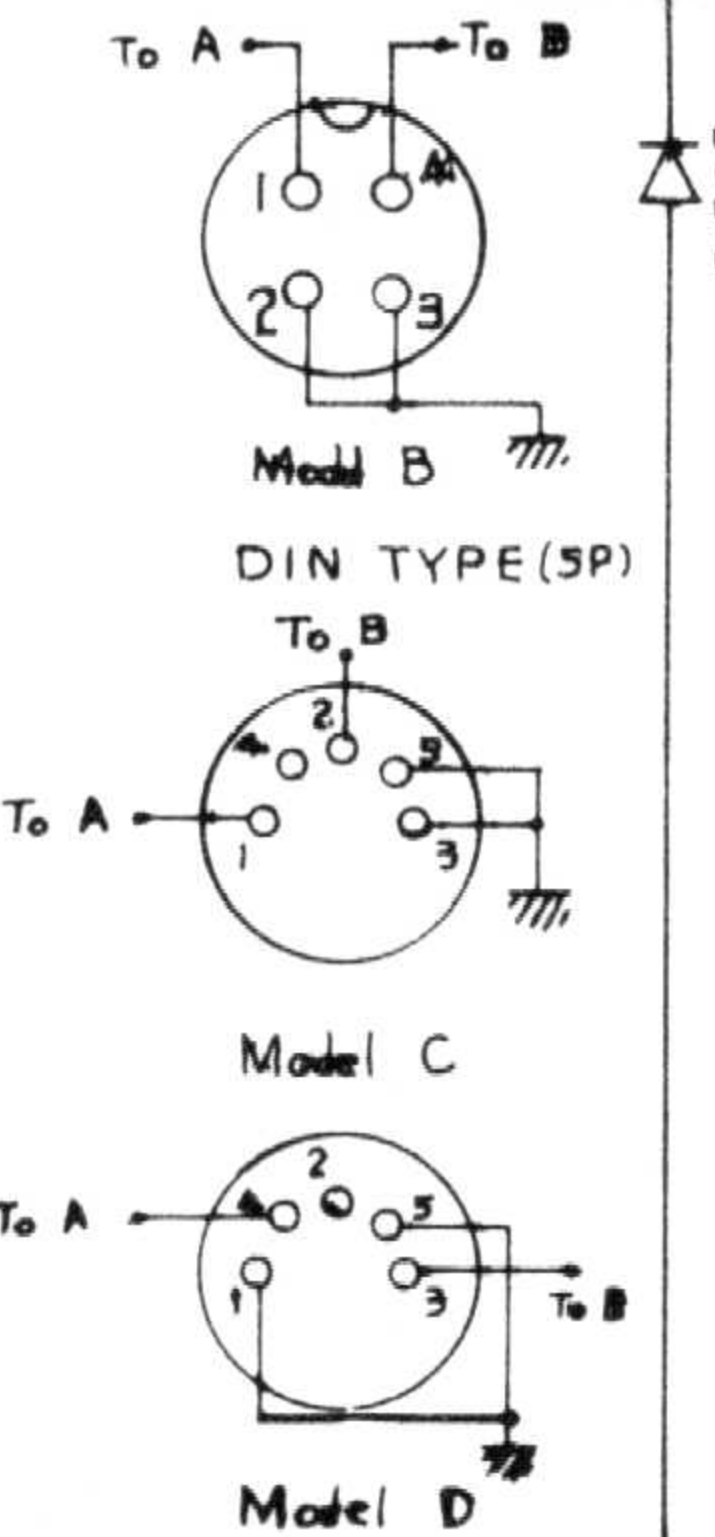

**VC-100**

Scan copyright 2009 Patrick Jankowiak  
[www.bunkerofdoom.com](http://www.bunkerofdoom.com)  
[www.magnetsphere.net](http://www.magnetsphere.net)

This document may be freely copied and shared. No part of this document may be sold, leased, or rented. No fee for access to this document, including website access or subscription fees, may be charged or collected for access to this document nor may it be bundled with any other item for which a fee is in any way associated.



pilot signal.

- a. Set the SWITCH 7 to the PEE position.
  - b. Then the pilot signal is sent by releasing the PTT button and let your partner know that your transmission is ended. This function can be operated when the SWITCH 1 is set to either the ECHO, SCRAM or COMP position and can not be operated when it is set to the OFF position.
  - c. The pilot signal can be selected from two choices by the PEE SELECT switch at the rear of the unit.
6. Using only the MELO function or the end of transmission pilot signal.
- a. Set the SWITCH 1 to the ECHO position.
  - b. Turn the ECHO VOL control to the left and ECHO TIME control to the right until they stop.
  - c. Set the SWITCH 7 of the unit to the MELO or PEE position.

Note: Do not make the microphone too close to the built-in speaker when monitoring transmission voice with the unit. It may

cause feedback oscilation.

## Specifications

Supply voltage	11 to 15V DC
Current consumption	less than 1A
Microphone impedance	100ohms to 50Kohms
Audio output	1.5W
Audio input	1W max.
Microphone output	0 to 20mV
Scramble encoding frequency	3KHz crystal control fixed
Scramble decoding frequency	2.5 to 3.5KHz variable
Echo delay time	50 to 250msec
Musical signals	two melodies
Pilot signals	two tones
Microhpone receptacle	4 pins
Dimensions	120W × 40H × 137Dmm
Included accesaries	
Mount bracket	1
Screws	4
Spare fuse	1
Operation manual	1